

Attachment of bearings

No. 2.08

Scope

This Guidance Note gives information about practical detailing for the attachment of bearings to plate girder and box girder bridges. For advice on bearing selection, see GN 3.03.

General

Bearings for steel girder bridges are of many types, such as knuckle bearings, sliding bearings, elastomeric pot bearings or laminated bearings. They can be proprietary products or purpose-made (the latter are usually all-steel bearings, such as knuckle bearings). The design of bearings should be in accordance with EN 1337 (Ref 1) but it does not cover the attachment of the bearings to the structure. This Note describes attachment details that are commonly used, and explains the design principles that are normally applied.

Form of attachment

It is now a general requirement that bridge bearings should be designed to be replaceable. (The requirement is reflected in advice in the draft PD 6703, Ref 2.) This requirement may be more relevant to those bearings which have elastomeric elements (the elastomer has a finite life), but it is a reasonable precaution in most cases.

The consequence of this requirement is almost always that the bearings are bolted in place, rather than welded. Typically a four-bolt arrangement is provided on each of the upper and lower elements. The bearing is bolted to the girder flange at the top and to holding down bolts set in reinforced concrete at the bottom.

For several practical reasons, a 'bearing plate' is usually provided between the bottom flange and the upper element of the bearing. In most cases with parallel-flanged girders of highway bridges the girder soffit is not horizontal (because the roadway is on a gradient or a vertical curve), yet the top surface of the upper bearing plate almost always needs to be set nominally horizontal (to avoid horizontal components arising from vertical reactions). The bearing plate is therefore usually tapered (and in bridges with integral crossheads is often tapered in both directions). Tapered bearing plates are also provided on railway bridges, although the taper is normally small.

There are two ways in which the bearings are bolted to the girders - using bolts through the upper bearing element, the (tapered) bearing plate and the bottom flange, or by bolting through the upper bearing element into tapped holes. The design issues to be considered for these two methods are explained below.

Bolting through the girder flange

Simply bolting through all the elements is perhaps the most immediately obvious means to attach the bearing. This makes an ordinary bolted structural connection that can be designed to EN 1993-1-8 (Ref 3), provided that preloaded bolts are used. With bolts in normal clearance holes, there is no loss of effective flange area in a compression flange (see EN 1993-1-1, clause 6.2.5 (6) (Ref 4)).

Bolts are usually fixed with heads uppermost. This facilitates the installation/removal of long bolts and avoids tightening nuts onto non-square faces.

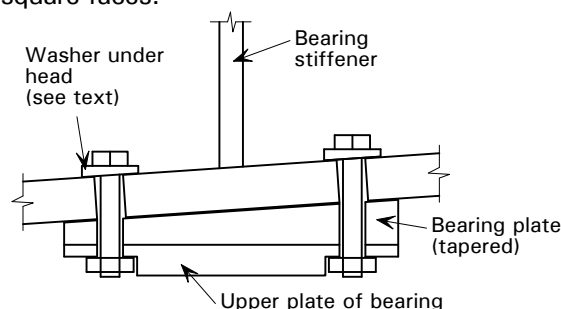

Figure 1 Attachment by through bolting

Preloaded bolts can be used without tapered washers when the face under the head is up to about 2° from square to the bolt axis (i.e. about 3.5% gradient).

Difficulties arise, however, with thick flanges and moderately large gradient in elevation. For example, a gradient of 2.5% and a flange thickness of 60 mm reduce the effective clearance of a vertical bolt in an inclined hole by 1.5 mm. (During fabrication, it is only feasible to drill square to the plate surface, not at an angle.) This reduction in clearance would make assembly difficult and it is better from that point of view to use a slightly oversize hole. However, in that case the design resistance (to shear along the interface) is reduced by virtue of the application of a reduction factor k_s and the effective area of the com-

Guidance Note

No. 2.08

pression flange will need to be reduced for the bolt holes (see EN 1993-1-8, clause 3.9.1).

Other difficulties with this method include clashes between bolts and bearing stiffeners, and entrapment of bolts in concrete at diaphragms (see Figure 2).

Bolting using tapped holes

Bearing manufacturers consider that attachment using non-preloaded bolts into tapped holes is a satisfactory method of attaching bearings, and this is by far the most popular method. The most common way of arranging this is to tap the tapered bearing plate, then weld it to the underside of the girder flange. The bolts are tightened but not tensioned to proof load (the bearing plate has a much lower material strength than the bolt). The problem with this detail is that there are no design rules (in EN 1337 or EN 1993) for the strength of the connection, nor any specific requirement for minimum engagement in the tapped hole.

Nevertheless, it is a commonly used detail, and should be satisfactory, provided that the following rules are observed:

- Use grade 8.8 bolts. The size should be sufficient for the design shear and at least M12.
- Use grade S355 steel for the bearing plate.
- Ensure that a length of thread of at least the bolt diameter is engaged in the tapped hole.

Note that welding the plate to the flange creates a detail with a fatigue category between 36 and 56, depending on thickness, as described in EN 1993-1-9, Table 8.5 (Ref 5). This may govern fatigue design at this position, especially at intermediate supports or at fixed bearings of railway bridges, where the shear forces are high. In such cases bolting through the flange may be preferable.

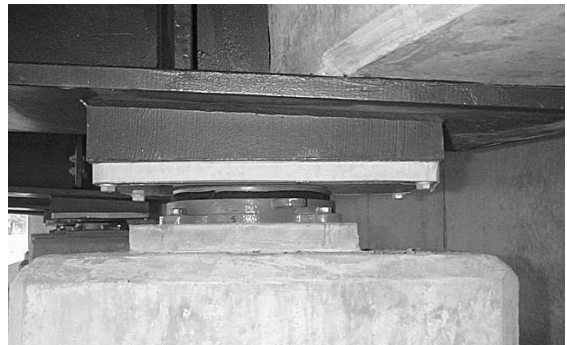

Figure 2 Attachment by bolts in tapped holes (bearing plate is welded to flange)

Additional attachments

Whilst sliding bearings are best fixed with the sliding surface facing downward so that extraneous material cannot fall onto the sliding surface, they are often mounted 'inverted' to avoid eccentric loading to the bearing stiffener. In such cases skirts should be provided (to prevent dirt, etc. reaching the upward facing sliding surface). These can usually be attached to the upper part of the bearing, rather than the girder flange. See Figure 3.



Figure 3 Guided bearing (with skirt)

References

1. EN 1337 Structural Bearings, Parts 1 to 11.
2. PD 6703 Structural bearings. Guidance on the use of structural bearings (due to be published in 2009).
3. EN 1993-1-8:2005, Eurocode 3 Design of steel structures. Design of joints.
4. EN 1993-1-1:2005, Eurocode 3 Design of steel structures. General rules and rules for buildings
5. EN 1993-1-9:2005, Eurocode 3 Design of steel structures. Fatigue