

Scheme development: Overview of structural systems for single-storey buildings

This document describes the range of structural systems that are commonly used for long span single storey buildings. The descriptions include the main structural frames, secondary systems such as bracing and the purlins and rails to support the cladding.

Contents

1.	Overview of applications for single storey buildings	2
2.	Basics for design	2
3.	Typical structural frame solutions	6
4.	Connections	18
5.	Acknowledgement	20

1. Overview of applications for single storey buildings

Single storey buildings find application in a wide range of buildings, from small homes to the largest covered spaces, such as exhibition halls and stadia. This document is however restricted to the middle range of spans between 20 m and 60 m. Large buildings will use multi-span structures and may, on occasion, cover 100 000 m².

This building form has its origins in industrial building and this description is still often applied but it is misleading as end uses are many and varied with considerable usage by the general public. Typical end uses are retail, distribution centres, call centres, leisure facilities, and indoor sports facilities.

This wider exposure to the public and increased emphasis on the conservation of energy has lead to a greater focus on the envelope in terms of aesthetics, insulation, airtightness etc. The title of industrial buildings has therefore been replaced by the broader term, single storey buildings. These are sometimes colloquially known as sheds.

While there has been considerable change in the appearance the basic structural forms have changed little other than to evolve in the details needed to support more varied cladding forms as described in later sections.

2. Basics for design

2.1 Overview of components

The most common form for the main frames is a low pitch portal frame but other structural forms such as trusses and beam and column structures are used. In these notes the portal frame has been chosen as the typical generic form but the comments on design philosophy may apply to the other forms too. However, variations are used in different regions. For example, in Nordic countries the roof cladding often spans between the rafters and is designed for diaphragm action so negating the need for bracing members. When this is done, the need for moment resisting connections in the frame is avoided but wall bracing or diaphragm action has to be provided in appropriate elevations.

Figure 2.1 shows a typical building with steel sheet cladding.

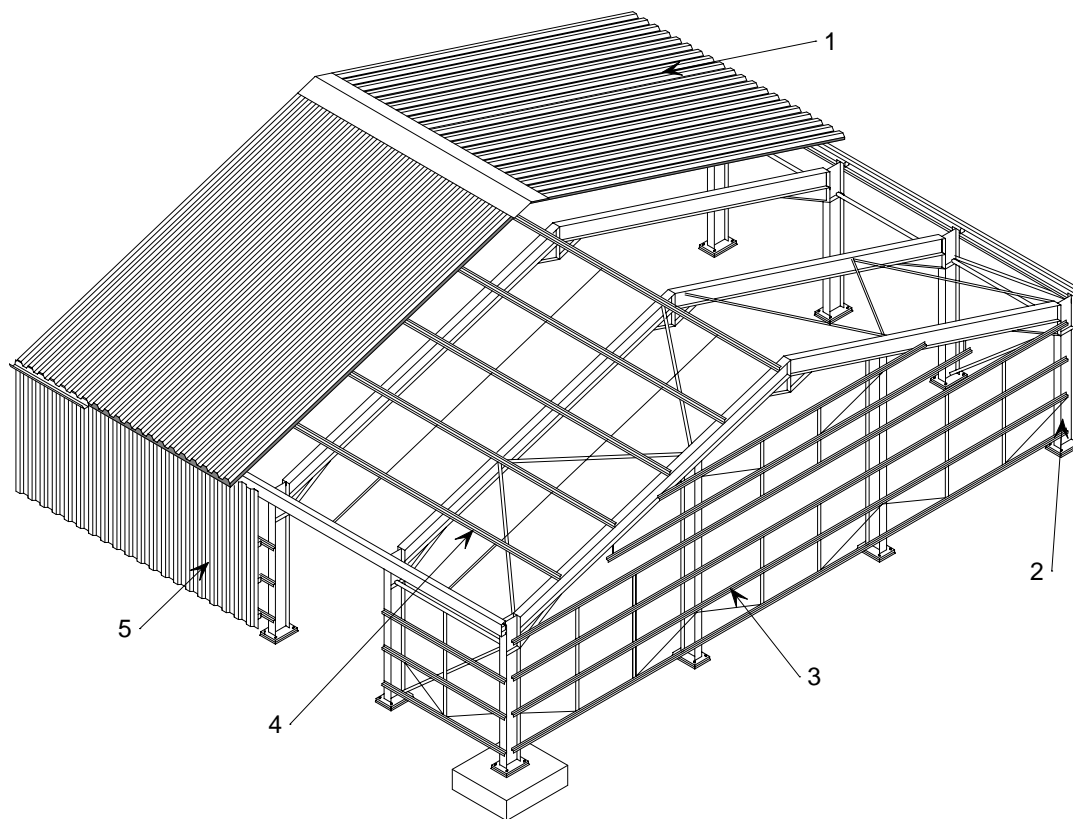

Key

- | | |
|------------------------|------------------|
| 1. Steel roof cladding | 4. Purlins |
| 2. Primary steel frame | 5. Wall cladding |
| 3. Side rails | |

Figure 2.1 Typical single storey building

The different forms of cladding are described in [SS018](#) and [SS019](#). The cladding is commonly supported on purlins (roofs) and rails (walls) although practices do differ in some regions. The purlins and rails are often formed by cold rolling galvanized coil into Zed or channel based sections which then span between frames.

Common spans are 1,5 to 2,0 m for the cladding and 6 to 8 m for the secondary members.

In some countries the distance between frames is less and cladding systems have been developed which span directly between the frames. In others deep trough trapezoidal cladding has been developed and this can span between frames at 6 to 10 m spacing.

The span range for the frames extends from 15 to 60 m but spans between 20 and 30 m are generally the most economic.

Frame designs are based either on plastic or elastic principles. Plastic design is employed with the arrangement using purlins and rails since these are able to provide the necessary restraints needed for economic design. Elastic principles are generally used where the cladding spans between frames.

Plastic design tends to result in more economic use of materials.

2.2 Structural principles for frames

As with any structure the requirements are to provide a robust method of transferring the applied loads to the ground via the foundations. For single storey buildings the principal loads, apart from self-weight will be snow and wind although in some areas seismic loads may need to be considered. Additionally, in some buildings, services and internal finishes are suspended from the frame and secondary members.

Gravity loads, which should be obtained from the relevant loading code (EN 1991) are transferred to the frames by the cladding or purlins and the frames designed according to the structural form chosen. The frames are designed as plane frames acting independently from each other.

Lateral loads acting in the plane of the main frames are most commonly resisted by each frame individually in a similar manner to the gravity loads.

When detailing frames it is usual to assume pin bases and use moment resisting connections at the eaves. Where fabricated tapered frames are used this will be especially true. This is more reliable than the use of “fixed” bases at the foundations due to the unreliable nature of the interface between the foundations and the ground. However, in some regions where the ground is known to be reliable, fixed bases are used with hot rolled section columns as the moment capacity is uniform at the top and bottom of the column.

In non-portal type structures it may be appropriate to use a wind girder to transmit the lateral loads to the gable frames which are then braced. This arrangement is used due to the difficulty in providing moment resistance between the roof trusses and the columns. This reduces the column size too.

For the horizontal loads acting perpendicular to the main frames it will be necessary to transmit the loads to the side elevations and then provide bracing to transmit them to the foundations.

Figure 2.2 illustrates typical layouts.

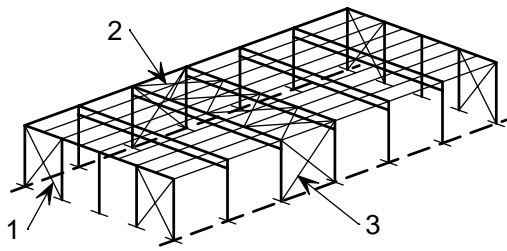

- Key:
- 1 Gable bracing
 - 2 Roof bracing
 - 3 Longitudinal bracing

(a) Layout with braced gable frames

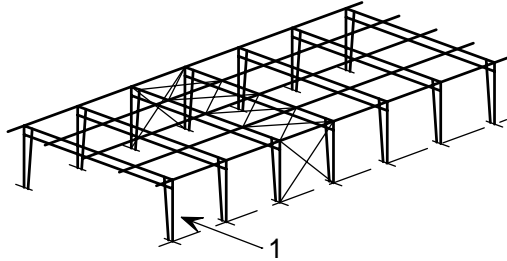

- Key:
- 1 Portalised end bay

(b) Layout with portalised gable frame

Figure 2.2 Typical structural layouts for portal frame buildings

Figure 2.2(a) shows a building with the transverse bracing near the central bay of the building. This is to be preferred as any thermal expansion can take place away from the “rigid” bay. However, the loads from the gable posts have to be transmitted along the roof to the braced bay. It is often more convenient to locate the bracing in the roof in the end bays.

The braced bays in the longitudinal elevation do not have to coincide with the roof bracing providing that a suitable member is provided at the eaves level to transfer loads between the two systems. This is often important to allow large doors and windows to be positioned in the most convenient location for the operation of the building rather than structural convenience.

Where the end frames are portalised as in Figure 2.2, there is no need for gable bracing. Where this cannot be achieved then a moment frame can be successfully used in place of cross bracing systems, see Figure 2.3.

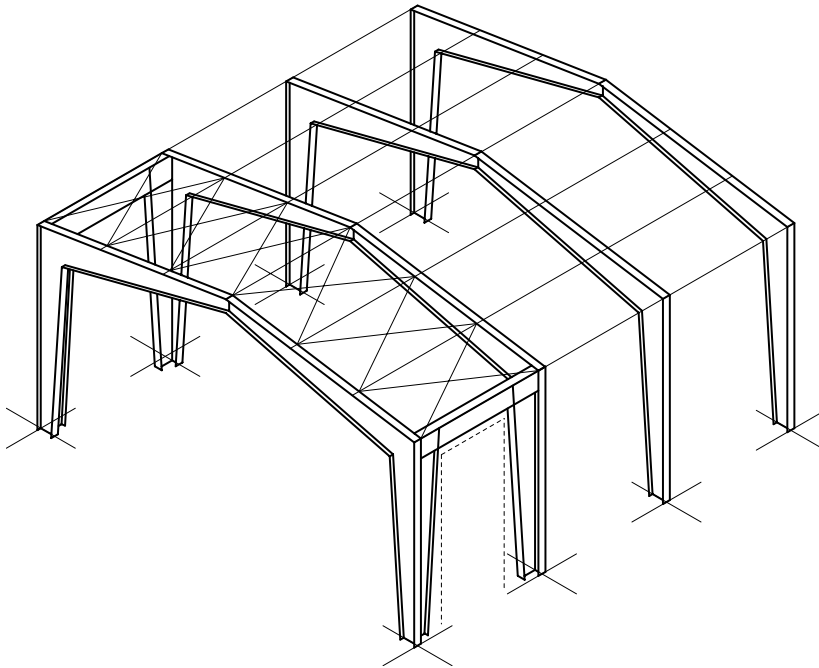

Figure 2.3 *Moment frame for stabilisation in longitudinal direction*

Cross bracing has been shown in the figures but W or K bracing is often used with tubular members designed for both tension and compression. This facilitates the erection process.

3. Typical structural frame solutions

3.1 Portal frames

The prevalent structural form for main frames is the steel portal frame. Portal frames can be manufactured from either hot rolled sections or plates automatically welded to form I sections. Some variants on the basic forms are shown in Figure 3.1.

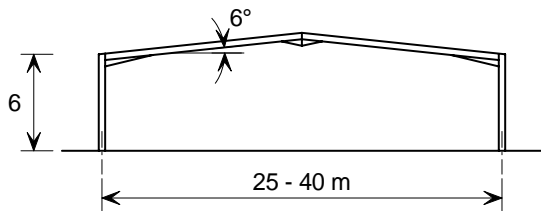

(a) Portal frame – medium span

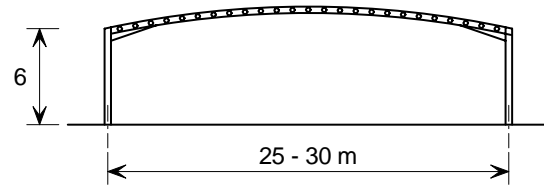

(b) Curved portal frame

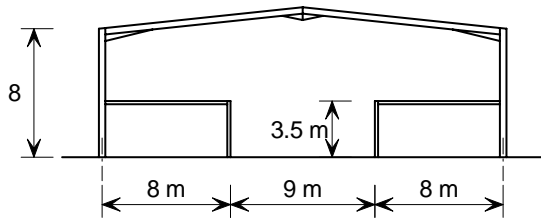

(c) Portal frame with mezzanine floor

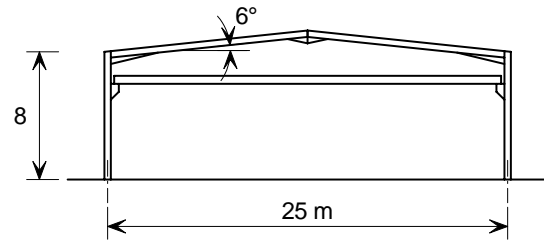

(d) Portal frame with overhead crane

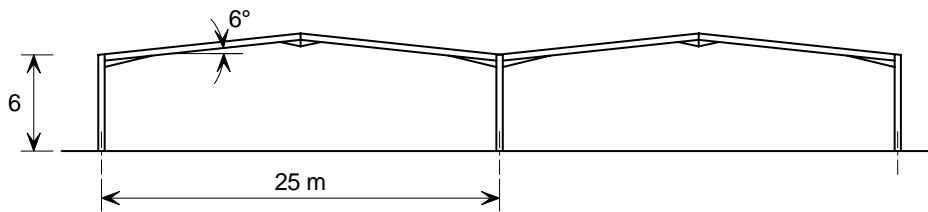

(e) Two bay portal frame

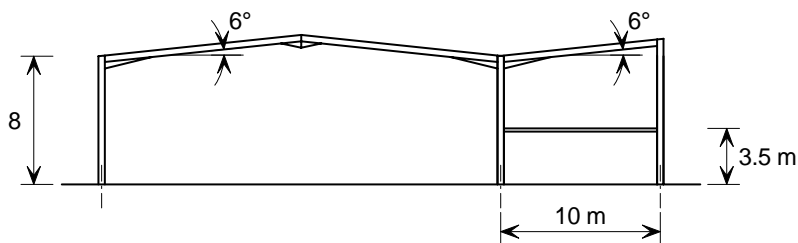

(f) Portal frame with integral office

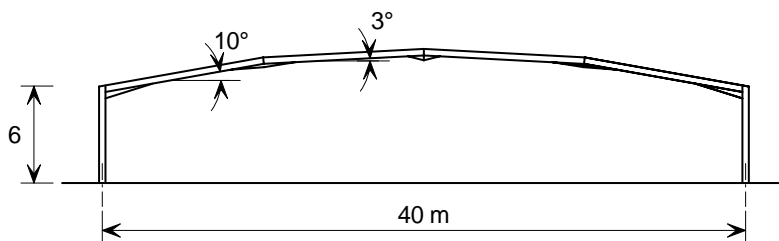

(g) Mansard portal frame

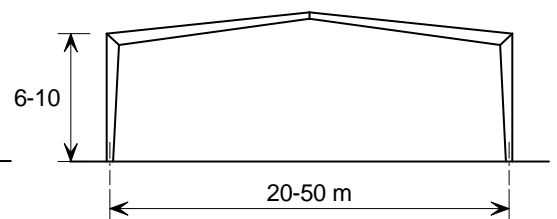

(h) Portal frame from welded plates

Figure 3.1 Various forms of portal frame

The dimensions given are purely indicative as an extremely wide range of heights and spans can be economically constructed. For large buildings it is generally more economic to divide them into spans of 20 – 30 m providing the use of the building is not disadvantaged by the presence of internal columns. The bay spacing between frames is between 4.5 and 10 m with 6 to 8 m the most common when purlin systems are used and the lower end when the cladding spans directly between frames.

As has been described in the introduction this form of construction is used for many purposes other than the original industrial function and designers have introduced variations on the theme which make the buildings and their cladding systems more attractive and appropriate for different environments. Examples are the use of parapets (Figure 3.2) to disguise the pitched roof shape of the buildings. The plain box shape without the industrial connotations is attractive architecturally and the use of cellular beams which are expressed externally (Figure 3.3) is an example of alternative architectural treatments.



Figure 3.2 Typical portal frame and secondary components



Figure 3.3 *Cellular beam used in portal frames*

Figure 3.4 illustrates how novel connection design can enhance the aesthetics. Designers are able to demonstrate innovative thinking while retaining the overall economy of the structural form.



Figure 3.4 *Innovative moment-resisting connections in an industrial building*

3.2 Truss roof alternatives

Solutions using roof trusses are a viable alternative to portal frames particularly where long spans are required. Portal frames are limited by the availability of sections and do not give the freedom for design expression which lightweight structures provide in large open spaces. Truss structures can be fabricated from channel, H section or tubular components.

As with portal solutions there are several derivatives to help satisfy the particular needs of the client and building function and appearance.

The necessary lateral stability can be achieved by designing the frame to have moment resisting connections between the trusses and the columns, by providing wind trusses in the roof plane or by using diaphragm action of the roof cladding (the latter two options require suitable restraint at the end walls and diaphragm action is not acceptable in some countries).

3.3 Portal frames

This section provides a more detailed review of the common portal frame arrangements.

3.3.1 Pitched roof portal frame

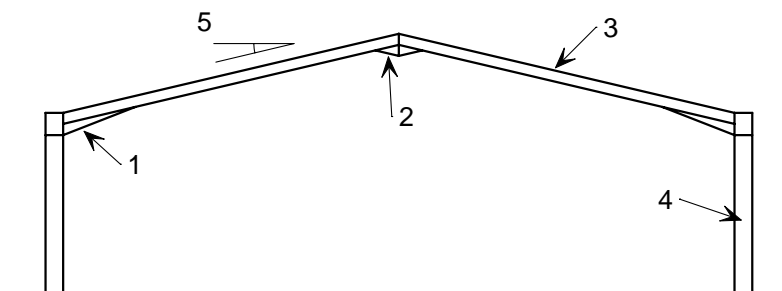

Key: 1. Eaves haunch 4. Column
 2. Apex haunch 5. Roof pitch
 3. Rafter

Figure 3.5 *Single-span symmetric portal frame*

A single-span symmetrical portal frame (see Figure 3.5) has typically:

- A span between 15 m and 60 m (20 to 30 m is the most efficient)
- An eaves height between 5 and 10 m (5 to 6 m is the most structurally efficient but the business activity often demands much higher buildings)
- A roof pitch between 5° and 10° (6° is commonly adopted)
- A frame spacing between 5 m and 8 m (the greater spacings being associated with the longer span portal frames)
- Haunches in the rafters at the eaves and if necessary at the apex.

The use of haunches at the eaves and apex both reduces the required depth of rafter and achieves an efficient moment connection at these points. Often the haunch is cut from the same size of section as the rafter.

3.3.2 Portal frame with mezzanine floor

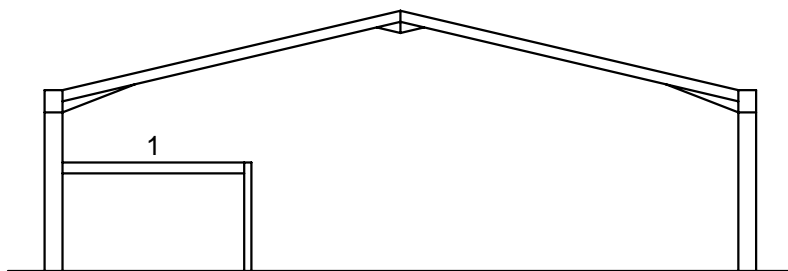

Key: 1. Internal Mezzanine

Figure 3.6 *Portal frame with internal mezzanine floor*

Office accommodation is often provided within a portal frame structure using a mezzanine floor (see Figure 3.6), which may be partial or full width. It can be designed to stabilise the frame, but often the internal floor requires additional fire protection.

3.3.3 Portal frame with external mezzanine

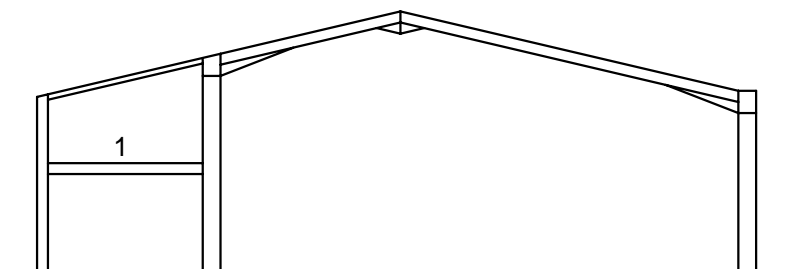

Key: 1. External Mezzanine

Figure 3.7 *Portal frame with external mezzanine*

Offices may be located externally to the portal frame which creates an asymmetric portal structure (as in Figure 3.7). The main advantage of this framework is that large columns and haunches do not obstruct the office space. Generally, this additional structure depends on the portal frame for its stability. Offices are often situated on the gable end and the structure may be beam and column rather than portal.

3.3.4 Crane portal frame with column brackets

Cranes, if functionally needed, have an essential influence on the design and the dimensions of portal frames. They provide additional vertical loads as well as considerable horizontal forces, which may influence calculation.

Where the crane is of relatively low capacity (up to say 20 tonnes), brackets can be fixed to the columns to support the crane (see Figure 3.8). Use of a tie member or fixed column bases may be necessary to reduce the eaves deflection. The outward movement of the frame at crane rail level may be of critical importance to the functioning of the crane.

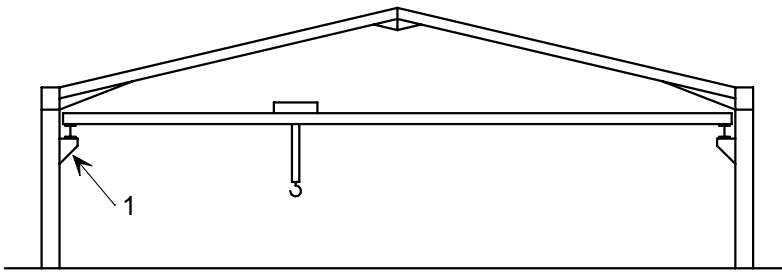

Key: 1. Column bracket

Figure 3.8 Crane portal frame with column brackets

For heavy cranes it is appropriate to support the crane rails on additional columns, which may be tied to the frame column by a bracing due to instability problems.

3.3.5 Propped portal frame

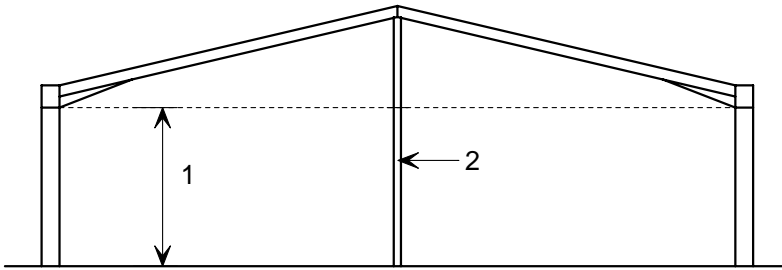

Key: 1. Clear internal height
2. Prop

Figure 3.9 Propped portal frame

Where the span of a portal frame is greater than say 30 m, and there is no need to provide a clear span, a propped portal frame (see Figure 3.9) can reduce the rafter size and also the horizontal shear forces at the base, giving economies in both steelwork and foundation costs.

This type of frame is sometimes referred to as a “single span propped portal”, but acts as a two-span portal frame in terms of structural behaviour.

3.3.6 Mansard portal frame

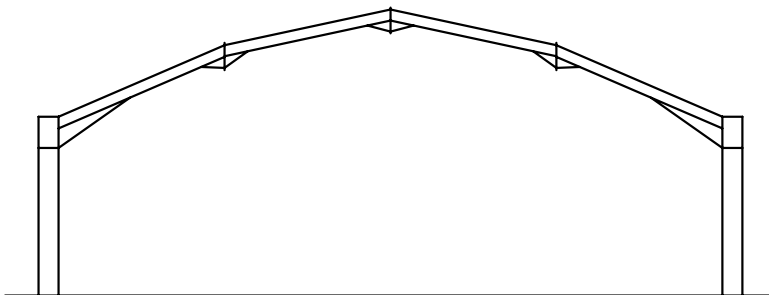

Figure 3.10 Mansard portal frame

A mansard portal frame consists of a series of rafters and haunches (as in Figure 3.10). It may be used where a large clear span is required but the eaves height of the building has to be

minimised. A tied mansard may be economic solution where there is a need to restrict eaves spread.

3.3.7 Cellular portal frame

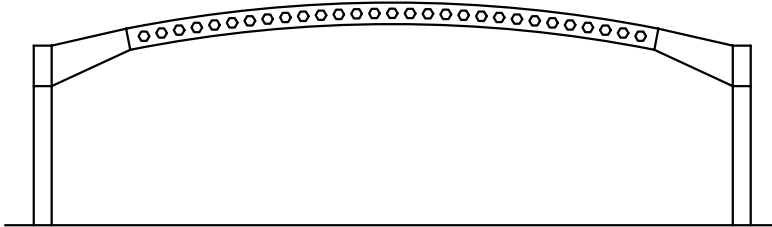
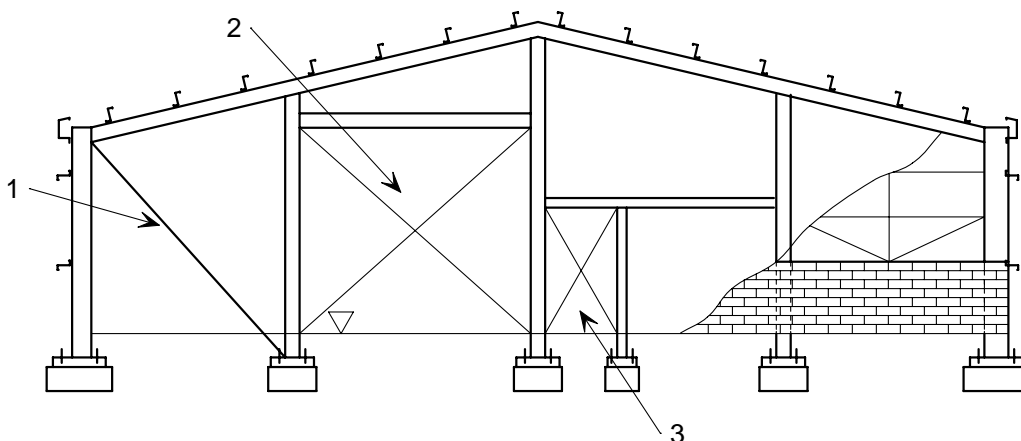

Figure 3.11 Cellular beam portal frame

Cellular beams may be used in portal frames often with curved rafters. Where splices are required in the rafter for transport, these should be carefully detailed to preserve the architectural features for this form of construction.

3.3.8 Gable wall frames



Key: 1. Gable bracing
2. Industrial door
3. Personnel door

Figure 3.12 Gable frame to a portal frame structure

Gable wall frames are located at the ends of the building and may comprise posts and simply-supported rafters rather than a full-span portal frame. Such frames require bracing to provide lateral stability (see Figure 3.12). If the building is to be extended later, a portal frame of the same size as the internal frames is preferred.

3.4 Overall building form

A typical steel portal frame structure with its secondary components is shown in Figure 3.13.

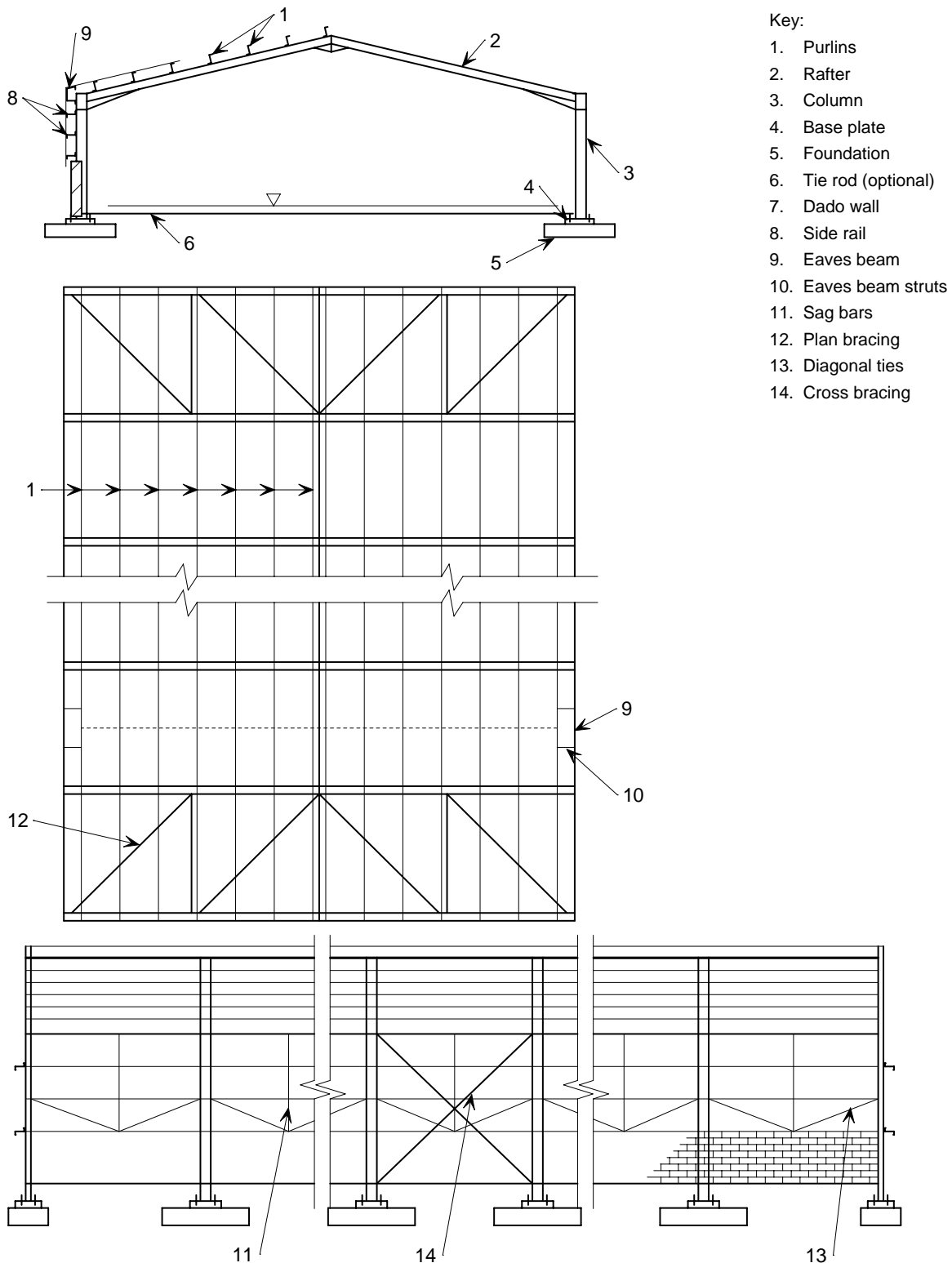

Figure 3.13 Overview of structural components in a portal frame structure

A portal frame is stable in its own plane, but it requires bracing out of its plane. This is generally achieved by bracing (often tubular members) in the plane of the roof spanning

between the outer frames. The nodes of this wind girder ideally coincide with the gable post connections. Purlins and side rails support the roof and wall cladding, and stabilise the steel framework against lateral buckling. Tubular members have the advantage of being able to resist both tension and compression and improve the stability during erection. However, angles can be used or even cables or flat strips where the system can be designed for tension only loads.

The installation process of the primary structure and secondary members, such as purlins, is generally carried out using mobile cranes, as illustrated in Figure 3.14. The spacing between the purlins is reduced in zones of higher wind and snow load, and where stability of the rafter is required, e.g. close to the eaves and valley.



Figure 3.14 Installation process for a modern portal frame

3.5 Secondary members

The cladding system of single storey building spans between the main frames and is supported directly on them or a purlin and rail system of secondary members is used. There is an interdependency with the frame design since if the more economic plastic design method is to be used, or the welded plate solutions, it is necessary to provide a restraint system to the compression flange. This then dictates the use of purlins to provide fixing for the restraints as shown in Figure 3.15.

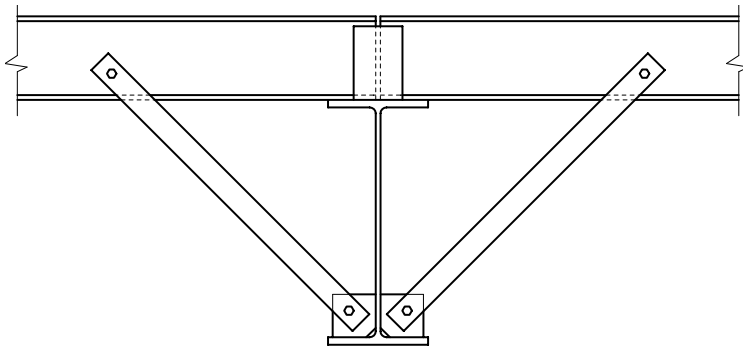

Figure 3.15 Restraints system at hinge positions

Purlin and rails are usually spaced at 1,5 to 2,0 m centres to provide the necessary restraints along the rafters and columns and this is also an economic span for most cladding profiles.

For economic reasons the purlins and rails are usually proprietary cold formed sections that are variants on Z or channel shapes. Figure 3.16 shows some typical shapes.

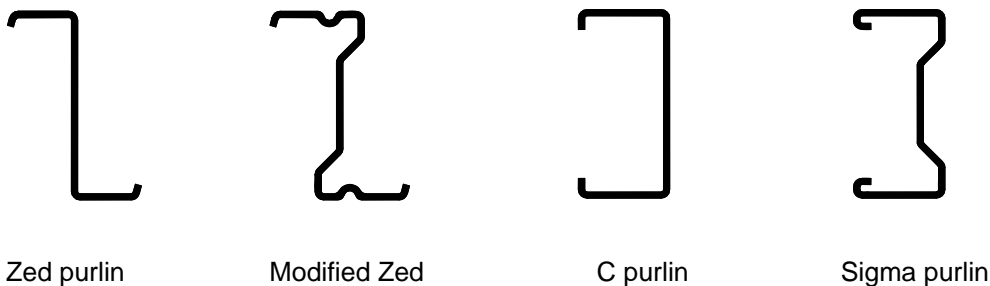

Figure 3.16 Typical purlin/rail sections

These are produced in a range of sizes and thicknesses to cover economically the loads and span ranges associated with the variety of single storey buildings constructed across Europe.

Cleats should be used to connect the cold formed sections to the rafters and columns since direct bearing can affect the performance of the components unless they have been specifically designed for that condition. Most manufacturers produce load tables for use within their products. These are often proven by test programmes to obtain maximum economy and it is essential that the manufacturers details are followed closely to ensure the test conditions are not contravened.

Hot rolled sections can be used for purlins and rails in particular where longer spanning cladding systems are used and so loadings are higher and where it is required to suspend significant loads from the roof system.

Figure 3.17 shows typical connection details.

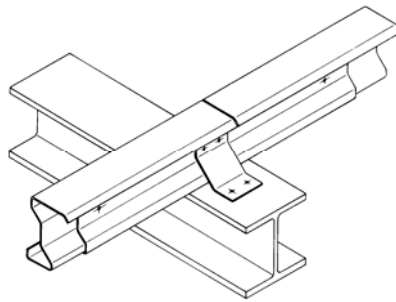

Support for continuous cold-formed Z-shaped purlin

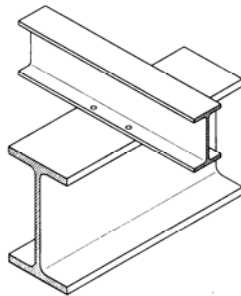

Support for continuous hot-rolled purlin

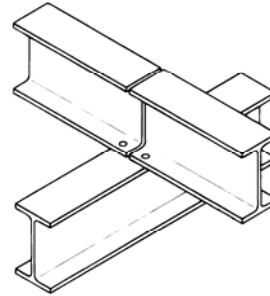

Support for single-span hot-rolled purlin

Figure 3.17 Possible solutions for purlin to rafter connection

More information on purlin design is given in T2006.

3.6 Valley beams for “hit” and “miss” frames

In multi-span portal framed buildings, it is common practice to use valley beams to eliminate some internal columns. Most commonly, alternate columns are omitted and the valley of the frame is supported on a valley-beam spanning between the columns of adjacent frames as shown in Figure 3.18. This arrangement is often referred to as “hit” and “miss” frames. The frames with the column are the “hit” frames. Sometimes more than one column is omitted, however such schemes require very large valley-beams and reduce the stiffness and stability of the structure, even where the remaining complete frames are used to stabilise the frames without columns.

Valley beams may be “simply supported” or “continuous” through the supporting columns. The choice will normally depend on the relative cost of a heavier beam for “simply supported construction” and the more expensive connection for “continuous construction”. Continuous may cause reduction of clear height near columns, as haunches will probably be required to allow economical bolted beam/column connections. This is not usually a problem.

Careful design is required to ensure that it is possible to fit the valley-beam and the rafters onto the column, especially if the column needs stiffeners in the same area. The first choice of column is often too small for the valley-beam to fit between the column flanges.

Valley-beams often form one or more portals with the columns to provide overall structural stability at right angles to the frames. This avoids the use of cross bracing on the internal column lines, which is often unacceptable for the intended use of the building.



*Figure 3.18 Valley beam details for “hit” and “miss” frame
(Photo courtesy Kingspan Metl-con Ltd)*

4. Connections

This section covers the main connection types for portal frames. Truss connections are discussed in document [SS050](#).

The three major connections in a single bay portal frame are those at the eaves, the apex and the column base. These are covered in more detail in document [SS051](#).

For the eaves connections mostly bolted connections are used with continuous columns combined with beams having end-plates as shown in Figure 4.1. In some case the column with the haunched span of the beam is constructed as a whole and the section of the beam with constant height is connected with a bolted joint.

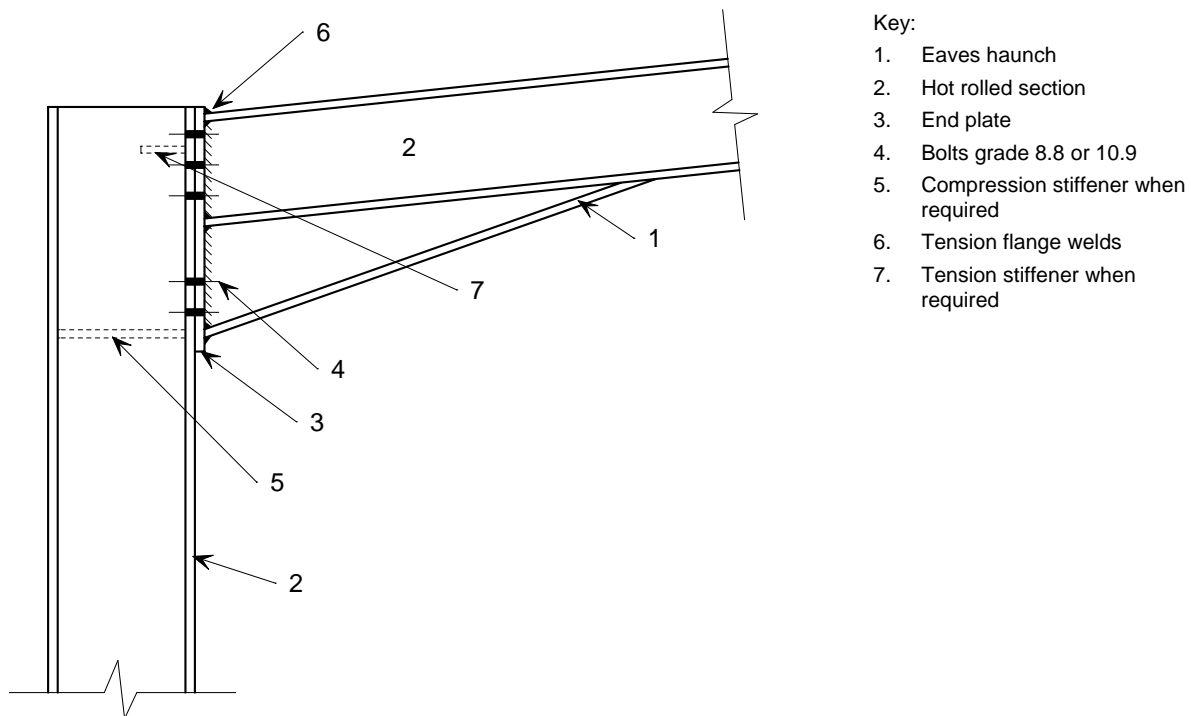

Figure 4.1 Typical eaves connections in a portal frame

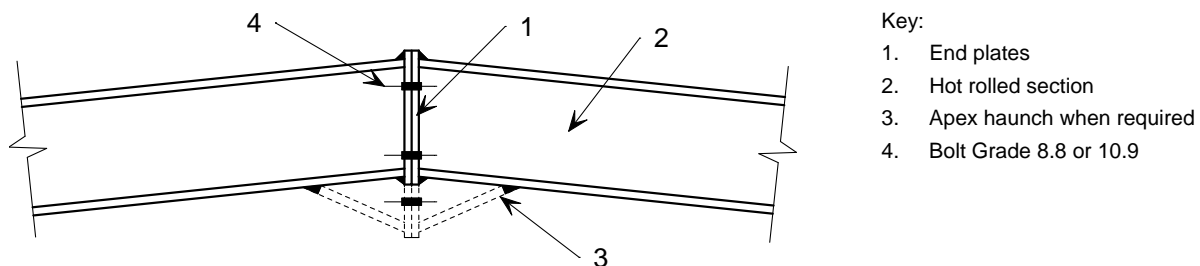

Figure 4.2 Typical apex connections in a portal frame

In order to reduce manufacturing costs it is preferable to design the eaves connection without stiffeners. If so, in some cases the effects of the reduced joint stiffness on the global structural behaviour have to be considered, i.e. effects on the internal forces distribution and the deflections of the structure. EN 1993 1 8 provides a design procedure, which takes these effects into account.

The apex connection is often designed similarly, see Figure 4.2. If the span of the frame does not exceed transportation limits, the on-site apex connection can be obsolete. The consulting engineer as well as the contractor should also avoid the apex haunch if possible, because of the increased fabrication costs.

The base of the frame column is often kept simple with larger tolerances in order to facilitate the interface between the concrete and steel workers, see Figure 4.3. In most cases it is designed as a pin to keep the dimension of the foundation as small as possible. It is important to realise that horizontal loads have to be resisted. Fixed bases can be used but only if there is reliable information on ground conditions. Although nominally the base is pinned four holding down bolts are preferred for safety reasons as they help prevent columns falling over in the temporary condition.

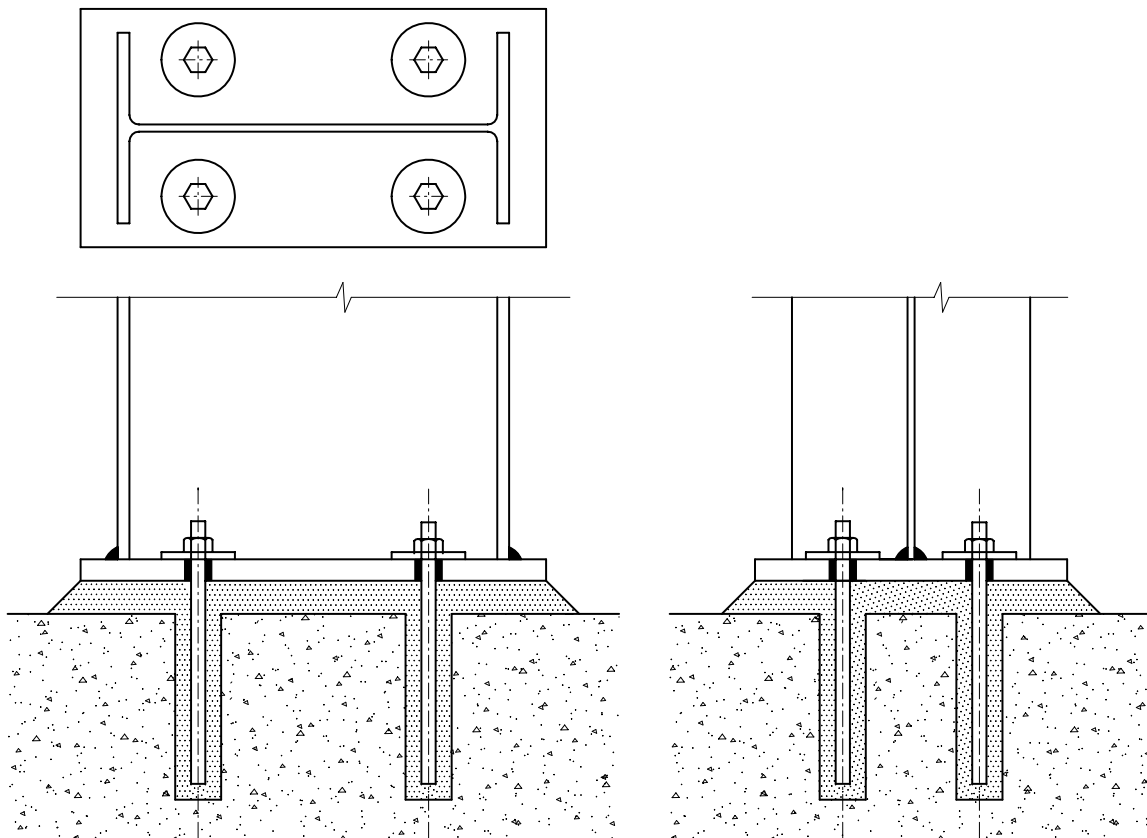

Figure 4.3 Typical examples of pin base connections in a portal frame

5. Acknowledgement

Some of the diagrams and illustrations in this document have been taken from *Annex 4-A (best practice – industrial sector)* of the report *Eurobuild in steel – Evaluation of client demand, sustainability and future regulations on the next generation of building design in steel*, which was a report to the ECSC steel RTD programme in 2006.

Quality Record

RESOURCE TITLE	Scheme development: Overview of structural systems for single-storey buildings		
Reference(s)			
ORIGINAL DOCUMENT			
	Name	Company	Date
Created by	Graham Raven	SCI	
Technical content checked by	G W Owens	SCI	
Editorial content checked by			
Technical content endorsed by the following STEEL Partners:			
1. UK	G W Owens	SCI	23/5/06
2. France	A Bureau	CTICM	23/5/06
3. Sweden	B Uppfeldt	SBI	23/5/06
4. Germany	C Müller	RWTH	23/5/06
5. Spain	J Chica	Labein	23/5/06
Resource approved by Technical Coordinator	G W Owens	SCI	14/7/06
TRANSLATED DOCUMENT			
This Translation made and checked by:			
Translated resource approved by:			

Wrapper Information

Title*	Scheme development: Overview of structural systems for single-storey buildings	
Series		
Description*	This document describes the range of structural systems that are commonly used for long span single storey buildings. The descriptions include the main structural frames, secondary systems such a bracing and the purlins and rails to support the cladding.	
Access Level*	Expertise	Practitioner
Identifiers*	Filename	P:\CMP\CMP554\Deliverables\Scheme Development\SS048a-EN-EU.doc
Format	Microsoft Office Word; 22 Pages; 2305kb;	
Category*	Resource Type	Scheme Development
	Viewpoint	Engineer, Architect
Subject*	Application Area(s)	Single-storey buildings
Dates	Created Date	25/05/2006
	Last Modified Date	
	Checked Date	
	Valid From	
	Valid To	
Language(s)*	English	
Contacts	Author	Graham Raven, SCI
	Checked By	G W Owens, SCI
	Approved by	
	Editor	
	Last Modified By	
Keywords*	Hot rolled steel products, Cold formed steel sections, Structural design concept, Single storey buildings, Retail buildings, Leisure buildings, Portal frame connections	
See Also	Eurocode Reference	
	Worked Example(s)	
	Commentary	
	Discussion	
	<i>Other</i>	
Coverage	National Applicability	EU
Special Instructions		