

*Best Practice in Steel Construction*

# COMMERCIAL BUILDINGS

Guidance for Architects, Designers & Constructors



Research Fund  
for Coal & Steel

# Contents



The Steel Construction Institute (SCI) develops and promotes the effective use of steel in construction. It is an independent, membership based organisation. SCI's research and development activities cover multi-storey structures, industrial buildings, bridges, civil engineering and offshore engineering. Activities encompass design guidance on structural steel, light steel and stainless steels, dynamic performance, fire engineering, sustainable construction, architectural design, building physics (acoustic and thermal performance), value engineering, and information technology.

[www.steel-sci.org](http://www.steel-sci.org)

**This publication presents best practice for the design of steel construction technologies used in commercial buildings, and is aimed at architects and other members of the design team in the early stages of planning a commercial building project. It was prepared as one of a series of three under an RFCS dissemination project Euro-Build in Steel (Project n° RFS2-CT-2007-00029). The project's objective is to present design information on best practice in steel, and to take a forward look at the next generation of steel buildings. The other publications cover best design practice in industrial and residential buildings.**

The Euro-Build project partners are:

- ArcelorMittal
- Bouwen met Staal
- Centre Technique Industriel de la Construction Métallique (CTICM)
- Forschungsvereinigung Stahlanwendung (FOSTA)
- Labein Technalia
- SBI
- The Steel Construction Institute (SCI)
- Technische Universität Dortmund

Although care has been taken to ensure, to the best of our knowledge, that all data and information contained herein are accurate to the extent that they relate to either matters of fact or accepted practice or matters of opinion at the time of publication, the partners in the Euro-Build project and the reviewers assume no responsibility for any errors in or misinterpretations of such data and/or information or any loss or damage arising from or related to their use.

ISBN 978-1-85942-130-7

© 2008. The Steel Construction Institute.

This project was carried out with financial support from the European Commission's Research Fund for Coal and Steel.

Front cover photograph: Tower Place (London), Architect: Foster and Partners.

## 01 Introduction



## 02 Key Design Factors



## 03 Floor Systems



## 04 Special Floor Systems



## 05 Beam Connections



## 06 Case Studies





# 01 Introduction

The design of commercial buildings is strongly influenced by issues such as the ability to provide column-free floor spans, efficient circulation space, integration of building services, and the influence of the site and local access conditions on the construction process. For inner city projects, speed of construction and minimum storage of materials on-site require a high level of pre-fabrication, which steel framed systems can provide.

A recent cost comparison study showed that the building structure generally accounts for only 10% of the total building cost and that the influence of the choice of structure on the foundations, services and cladding costs is often more significant. Therefore, best practice building design is a synthesis of architectural, structural, services, logistics and constructional issues. Where this synthesis has been achieved, long-span steel systems with provision for service integration have dominated commercial building design.

Figure 1.1 illustrates a modern commercial building in steel which provides a high quality, flexible and efficient working environment.



Figure 1.1 *Modern commercial building in steel, London*

# 02 Key Design Factors

The design of commercial buildings is affected by many factors. The following general guidance is presented to identify the key design factors and the benefits offered by steel and composite construction.

## Commercial building market

Typically, city centre projects are relatively large in floor area (8,000 - 20,000 m<sup>2</sup>) and 4-10 storeys in height. Most commercial buildings require floor spans in excess of 12 m, and there is a definite trend towards 15-18 m column-free spans. The maximum height of buildings is often controlled by planning authorities. This leads to the need to minimize the floor zone, for example by integrating structure and services in the same horizontal zone.

There is a strong demand for high quality office space, especially in city centres. Corporate headquarters for banks and other high profile companies require that buildings are built to high architectural and environmental standards. Investment 'value' is the main criterion for choice of the building architecture, form and servicing strategy. Many buildings are curved or of complex architectural form, and have highly glazed façades and atria.

Currently, there is a trend towards 'mixed use' developments. This involves the design of commercial, retail and residential parts of a 'live work play' environment, where all facilities are provided in one building or project. On the other hand, the recent trend to build on 'greenfield' (virgin land not previously built upon) or out of town sites (such as science and technology parks) has noticeably decreased, as planning pressure to build in city centres increases.

Composite construction has become the preferred medium of building, as shown in Figure 2.1. This technology also provides opportunities for service integration in long-span construction. Pre-assembly of services, lifts, toilets and plant rooms is also important in major projects.

Long-term flexibility in use is an important issue to clients and speculative developers, whilst information technology and Building Management Systems (BMS) are increasingly valuable in planning, design and operation.

## Construction programme

The construction programme should be considered at the same stage as the evaluation of the cost of structure, the services, cladding and finishes. The structural scheme has a key influence on programme and cost. Structural solutions which allow early access for the following trades are beneficial in terms of early return on the clients' investment. Speed of construction is seen as the major selling point for steel.

## Constructional issues

### Site conditions

Increasingly, structures are constructed on poor ground conditions, or on 'brownfield' sites (land previously built upon). In city centres, major services and underground works, such as tunnels, often dominate the chosen solution.

*Commercial building market*

*Construction programme*

*Constructional issues*

*Design issues*

*Fire safety*

*Thermal performance*

*Loading*



*Figure 2.1 Composite floors create a safe working platform during construction*

Poor ground conditions tend to require a lightweight solution involving fewer foundations. This often necessitates longer spans for the superstructure. A steel structure is up to 50% lighter than an equivalent concrete structure.

A confined site can place constraints on choice of the structural scheme, for example the size of the elements that can be delivered and erected. Composite flooring is often preferred in these cases.

### **Cranes**

Multi-storey structures are often erected using a tower crane. The number of cranes required on a project is influenced by:

- The site 'footprint' - can cranes provide a sensible coverage of the building site, including off-loading of materials?
- The size of the project - can more than one crane be utilised effectively?
- Commercial decisions on cost and programme benefits.

Installation rates are dominated by 'hook time' - the time connected to the crane. Fewer pieces to install, or use of more cranes, will reduce the construction programme. Smaller inner city sites are often served by a single tower crane that is used by all trades.

These competing demands can slow overall progress of the steelwork erection. For larger projects, it is an important requirement to enable other trades to commence their activities as the steelwork installation progresses.

### **Installation rates**

As an indication, an installation rate of between 20 and 30 pieces of steel per day is reasonable for most commercial building projects. For average weights of the components, this equates to approximately 10 to 12 tonnes of steel per day. Therefore there is a benefit in using fewer longer span beams, which can reduce the number of components by up to 25%.

### **Composite floors**

Composite floors comprise profiled steel decking, which is lifted onto the steelwork in bundles and usually man-handled into position. A fall arrest system is installed immediately after the steelwork and before the decking is placed. Decking is usually placed soon after the steelwork is erected.

Completed and decked floors may be used as a safe working platform for subsequent installation of steelwork, as shown in Figure 2.1. For this reason, the upper floor in any group of floors (usually three floor levels) is often concreted first.

### **Precast concrete planks**

Placing of precast concrete units becomes difficult if these have to be lowered through the steelwork. Better practice is to place the units as the steelwork for each floor is installed. In this case, the precast concrete supply and installation may be part of the Steelwork Contractor's package.

### **Design issues**

#### **Design life**

When proposing any structural scheme, it is acknowledged that the structure has a much longer design life than other building components. For example, services have a design life of around 15 years, compared to a design life of 60 years for the structure. Building envelopes for typical office construction have a design life of between 30 and 60 years.

*"The construction programme benefits of steel construction have a major influence on early completion and financial return to the client."*



Similarly, the space use of the interior of the building is likely to change. Schemes that allow maximum flexibility of layout are preferred. A steel structure can be designed for future flexibility and adaptability by:

- Longer floor spans with fewer internal columns.
- Higher ceilings.
- Providing freedom in service distribution.

### Service integration

Despite the move to greater energy efficiency in buildings and, where possible, the use of natural ventilation strategies, most large commercial buildings will continue to require some form of mechanical ventilation and air conditioning. The provision for such systems is of critical importance as it affects the layout and type of members chosen in the structure.

The basic decision to either integrate the services within the structural depth or to suspend the services below the structure affects the choice of structure, the fire protection system, the cladding details and the overall building height.

The most commonly used systems are the Variable Air Volume system (VAV) and the Fan Coil (FCU) system. VAV systems are often used in buildings with single owner occupiers, because of their lower running costs. FCU systems are often used in speculative commercial buildings because of their lower capital costs.

Generally, a zone of 450 mm permits services to be suspended below the structure. An additional 150-200 mm is usually allowed for fire protection, ceiling and lighting units and a nominal structural deflection (25 mm). Terminal units (FCU or VAV units) are located between the steel beams where space is available. Some under-floor systems provide conditioned air through a raised floor.

Service integration is achieved by passing services through penetrations in the steel beams. These may be in the form of individual openings in rolled steel beams, or multiple regular or irregular openings in fabricated beams.

Cellular beams provide regular circular openings in the web, which are created by welding together two parts of a rolled steel section. The top and bottom steel sections may be cut from different sizes and from different beams in even different steel grades (hybrid sections). This allows both an efficient solution for service integration as well as an increase of bending resistance and stiffness. Elongated openings may also be created, as illustrated in Figure 2.2.

Integrated floor systems are of the minimum structural depth, and provide for flexibility in service distribution, as illustrated in Figure 2.3. Other innovative forms of integrated floors have been developed, as shown in Figure 2.4. In this project, the stainless steel decking is exposed and acts to regulate internal temperatures by the thermal capacity of the floor slab. The air conditioning and lighting system are integrated and remain visible.

### Floor dynamics

Floor response may be considered simply in terms of the fundamental frequency of the floor structure. If this is greater than 4 Hz, the floor is generally considered to be satisfactory. Whilst this simple criterion was generally acceptable for busy workplaces, it is not appropriate for quieter areas of buildings, where vibrations may be more perceptible.



Figure 2.2 Elongated openings in beams with horizontal stiffeners



Figure 2.3 Service distribution below the floor using integrated floor beams



Figure 2.4 Stainless steel composite decking used at the Luxembourg Chamber of Commerce  
Vasconi Architects

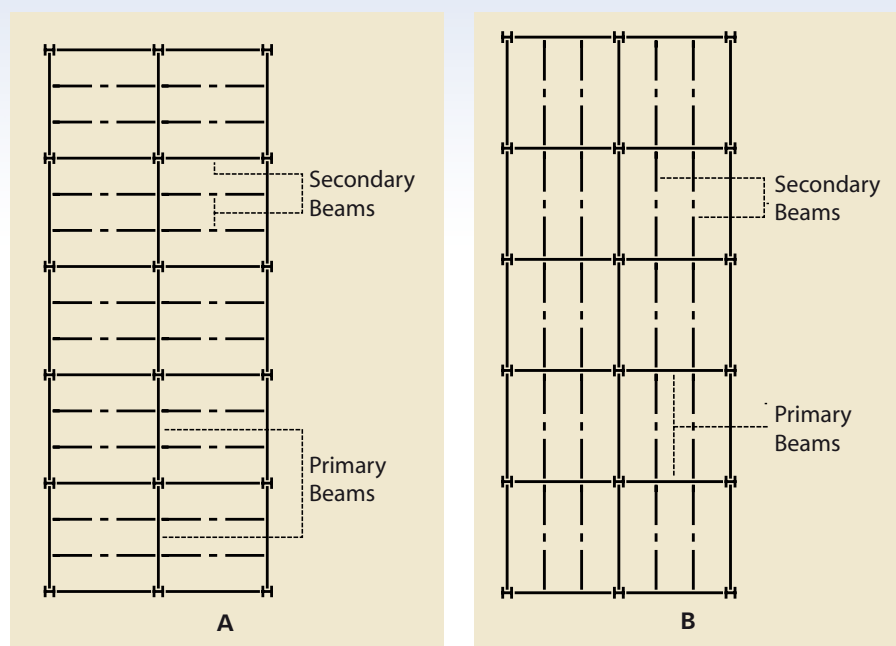

Figure 2.5 Alternative beam layouts in composite construction

A more appropriate approach is an assessment based on the level of the vibration, measured in terms of acceleration. Higher accelerations indicate a dynamic response that is more noticeable to the occupants.

In practice, response is reduced (i.e. vibration is less noticeable) by increasing the mass participating in the motion. Use of long-span beams generally creates less of a dynamic problem than shorter spans due to the higher effective mass of the larger floor area, which is contrary to ideas based on natural frequency alone.

Beam layout is often important, as longer continuous lines of secondary beams in composite construction result in lower response factors, because more mass participates in the motion with longer lines of beams. Figure 2.5 shows two possible arrangements of beams. The dynamic response for arrangement (B) will be lower (less noticeable) than arrangement (A), as the participating mass is increased in arrangement (B).

Damping reduces the dynamic response of a floor. Floor response is decreased by partitions at right angles to the main vibrating elements (usually the secondary beams), although the inclusion of this factor in design can prove unreliable, as the exact effect of

partitions is difficult to determine. Bare floors, particularly during construction, are likely to feel more 'lively' than when occupied because the fit-out of a building increases damping by as much as a factor of 3.

### Fire safety

Designers should consider fire safety when arranging or choosing the structural configuration and should address issues such as:

- Means of escape.
- Size of compartment.
- Access & facilities for the Fire Services.
- Limiting the spread of fire.
- Smoke control and evacuation.
- Adoption of sprinklers to prevent fire and control fire severity.
- Passive fire protection strategy.

### Fire resistance

The structural performance in the event of a fire should meet prescribed standards, usually expressed as a period of fire resistance of the structural components. As an alternative, a 'fire engineering' approach may be followed, which assesses the fire safety of the whole building, considering a natural fire development, the building use and active measures introduced to reduce the risk of a severe fire.

In general, the structural engineer should consider:

- Opportunities to use unprotected steel by 'fire engineering' analysis, considering the natural fire development and severity.
- Systems such as partially encased columns and integrated beams,

*“Lightweight steel construction may be designed to minimise vibration effects, by use of response factor methods. Longer span beams mobilise more effective mass and reduce vibration response.”*

which do not require additional fire protection.

- Influence of service integration on choice of the fire protection system, and off-site solutions, such as use of intumescent coatings.
- Influence of site-applied fire protection on the construction programme.
- Appearance of exposed steelwork when choosing a fire protection system.
- Schemes with fewer but heavier beams can result in overall savings in fire protection.

## Thermal performance

Thermal insulation of the building envelope is traditionally the architect's responsibility, but the structural engineer must be involved in the development of appropriate details. For example, supporting systems for cladding should be addressed, and steel members that penetrate the insulation, such as balcony supports, should be detailed to minimise the effects of 'thermal bridging'.

## Loading

Loading on structures is covered in EN 1991 *Eurocode 1. Actions on structures*. Recommended values for imposed loads are given in Part 1-1 and for fire loads in Part 1-2. Snow loads are given in Part 1-3 and wind actions in Part 1-4. Actions during construction can be found in Part 1-6.

Design checks are made at the ultimate limit state (ULS) and the serviceability limit state (SLS).

Wind loads are generally transferred from the façades via the slab to the concrete



Figure 2.6 Long-span cellular beams with offsite fire protection provide for freedom in servicing

core, which also encloses the staircases and elevators. Bracing systems located in the façades or rigid frame construction may be considered for buildings of up to six storeys height.

Long-span composite beams are often pre-cambered in order to offset the deflection of the steel beam under self-weight loads. Imposed loads are resisted by the stiffer composite section. The final deflection is a combination of the construction stage and in-service deflection.

### Self weight

As well as the self weight of the floors and frame, an additional load of  $0.7 \text{ kN/m}^2$  should be considered for raised floors, ceilings and building services equipment.

Table 2.1 presents typical self weights in multi-storey buildings.

### Imposed loading

Imposed loading is the variable loading that is applied to the structure and includes loads due to occupants, equipment, furniture and movable partitions, and also snow on roofs.

The magnitude of the imposed loading varies according to the use of any specific floor area being considered - different values are applied for a plant room or storage area, for example.

EN 1991-1-1 presents minimum imposed floor loads for different building uses. For offices, the design imposed loading is typically  $3 \text{ kN/m}^2$ . In addition, up to  $1 \text{ kN/m}^2$  may be added for movable partitions. For storage areas, a higher value of  $5 \text{ kN/m}^2$  may be used.

Table 2.1 Typical weights of building elements

Element	Typical weight
Precast units (spanning 6 m, designed for a $5 \text{ kN/m}^2$ imposed load)	3 to $4.5 \text{ kN/m}^2$
Composite slab (Normal weight concrete, 130 mm thick)	$2.6$ to $3.2 \text{ kN/m}^2$
Composite slab (Light weight aggregate concrete, 130 mm thick)	$2.1$ to $2.5 \text{ kN/m}^2$
Services	$0.25 \text{ kN/m}^2$
Ceilings	$0.1 \text{ kN/m}^2$
Steelwork (low-rise 2 to 6 storeys)	$35$ to $50 \text{ kg/m}^2$ ( $0.5 \text{ kN/m}^2$ )
Steelwork (medium-rise 7 to 12 storeys)	$40$ to $70 \text{ kg/m}^2$ ( $0.7 \text{ kN/m}^2$ )



# 03 Floor Systems

**This section describes the main floor systems used in multi-storey buildings. The characteristics of each floor system are described, together with guidance on important design issues.**

Floor structures comprise beams and slabs. The beams are attached to columns that are placed in the optimum locations for effective use of the space. Column-free space has become an important design requirement in modern commercial buildings to achieve flexibility in use. Many long-span beam systems have been developed with spans of up to 18 m, which means that internal columns are not required for many building layouts.

In addition to their function in supporting imposed loads, floors often act as horizontal diaphragms, ensuring horizontal forces are transferred to the vertical bracing, or cores. Furthermore, the floor components (floor slab, decking and beams) must also provide the required fire resistance as influenced by the building height and use.

Services may be integrated with the structural zone, or may be suspended below the floor. Structural floors may have a directly applied floor finish, or a screed, or a raised floor to provide distribution of electrical and communication services.

The following floor systems are described:

- Composite beams and composite slabs.
- Integrated floor beams
- Cellular beams (either using hot rolled steel sections or fabricated sections).
- Composite beams with precast concrete units.

- Integrated floor beams (also known as slim floor beams).
- Non-composite beams with pre-fabricated concrete slabs.

## **Composite construction**

Most steel construction systems in the commercial building sector are based on the principles of composite construction. Shear connectors are usually in the form of headed shear studs that are generally welded on-site through the steel decking to the beams.

Steel decking may have a re-entrant or trapezoidal profile. Re-entrant decking uses more concrete than trapezoidal decking, but has increased fire resistance for a given slab depth. Trapezoidal decking generally spans further than re-entrant decking, but the shear stud resistance is reduced due to the influence of the deeper profile shape.

Generally, normal weight concrete (NWC) is used, although in some countries, light weight aggregate concrete (LWAC) is efficient and widely available. Its dry density is in the range of 1700-1950 kg/m<sup>3</sup> in comparison to 2400 kg/m<sup>3</sup> for normal weight concrete.

Pre-fabricated hollowcore slabs may be used with non-composite beams, or may be designed compositely by use of pre-welded studs and reinforcement placed in the concrete-filled hollowcores. For solid pre-fabricated planks, the reinforcement is placed in the concrete topping over the planks.

## *Composite beams*

## *Integrated floor beams*

## *Cellular composite beams*

## *Long-span composite beams*

## *Composite beams with precast units*

## *Non-composite beams with precast units*

## Composite beams & composite slabs using steel decking

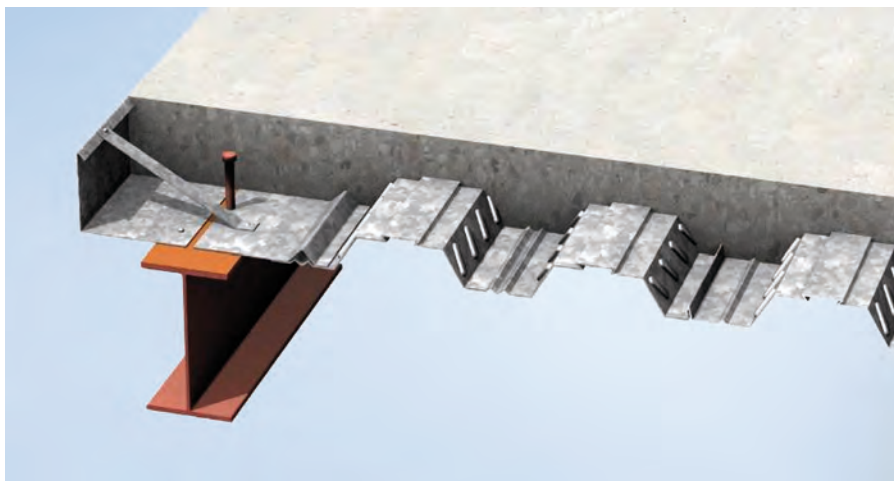

Figure 3.1 Edge beam in composite construction

### Description

Composite construction consists of I or H profile steel beams with shear connectors welded to the top flange to enable the beam to act compositely with an in-situ composite floor slab as shown in Figure 3.1. The concrete slab and the steel beam act together to increase the bending resistance and stiffness of the floor construction.

Composite slabs span between secondary beams, which in turn may be supported by primary beams. The secondary and primary beams are designed as composite. Edge beams can be designed as non-composite, although shear connectors may be used for reasons of structural integrity and transfer of wind loads. A typical example of a floor layout is shown in Figure 3.2.

The floor slab comprises shallow steel decking and a concrete topping, which act together compositely. Mesh reinforcement is placed in the slab to enhance the fire resistance of the slab, to distribute localised loads, to act as transverse reinforcement around the shear connectors and to reduce cracking in the slab.

The decking is normally designed without propping and supports the weight of the wet concrete and construction loading as a continuous member over at least two spans. The composite slab is normally designed as simply supported between beams.

Pre-design software is available free at: [www.arcelormittal.com/sections](http://www.arcelormittal.com/sections), [www.steel-sci.org](http://www.steel-sci.org) and [www.corusconstruction.com](http://www.corusconstruction.com).

### Typical beam span range

Secondary beams: 6 to 15 m span and at 2.5 m to 4 m spacing typically.  
Primary beams: 6 to 12 m span.

### Main design considerations for the floor layout

Secondary beams should be positioned to avoid propping of the decking during construction. Longer span secondary beams are usually preferred.

For shallow beams, services pass under the beams, and thus affect the overall floor zone. For deeper beams, openings may be cut in the web of the beam to provide for service distribution.

Edge beams may need to be deeper than internal beams because of limits on deflection under the weight of the cladding, particularly glazing.

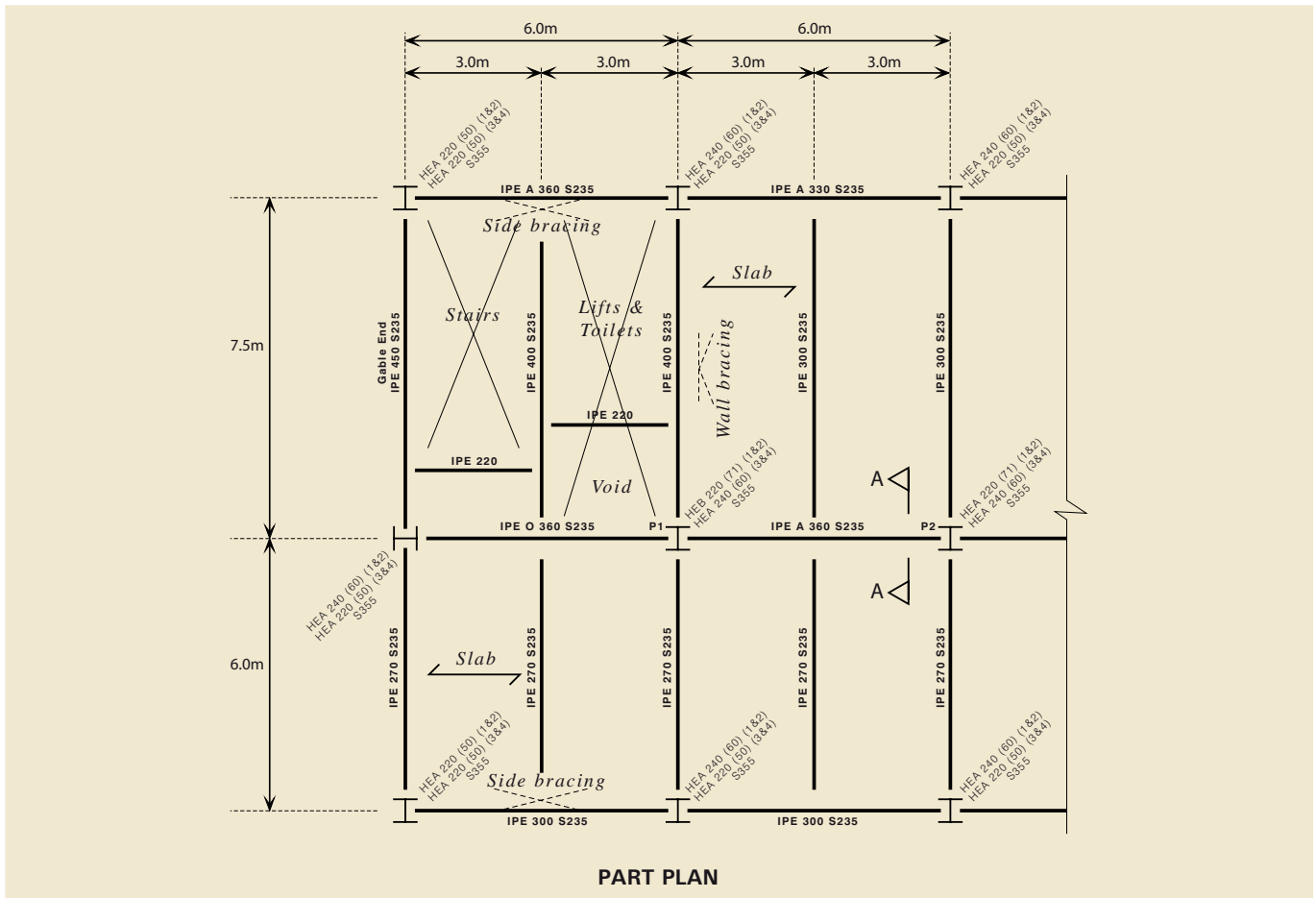

Floor zone  
 = 150 mm raised floor  
 + 130 mm slab  
 + 352 mm beam  
 + 150 mm ceiling & lighting  
 = 782 mm ≈ 800 mm

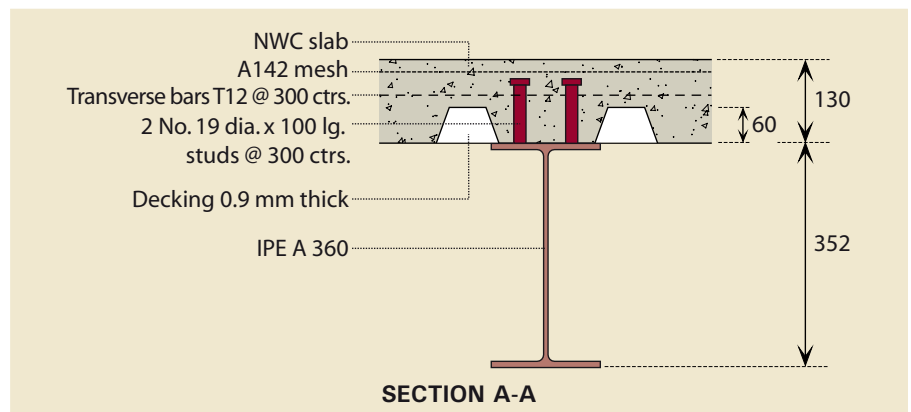

Figure 3.2 Typical composite beams ~ example of floor steelwork layout for 4 storey rectangular plan building

**Advantages**

- Shallower and lighter beams than in non-composite construction, therefore lightweight and more economic.
- Wide availability of hot rolled steel sections.

**Services integration**

The main heating and ventilation units can be positioned in the wide area between the beams, as in Figure 3.3, but ducts pass below the beams. Services may be passed through local openings in the web up to 60% of the section depth.



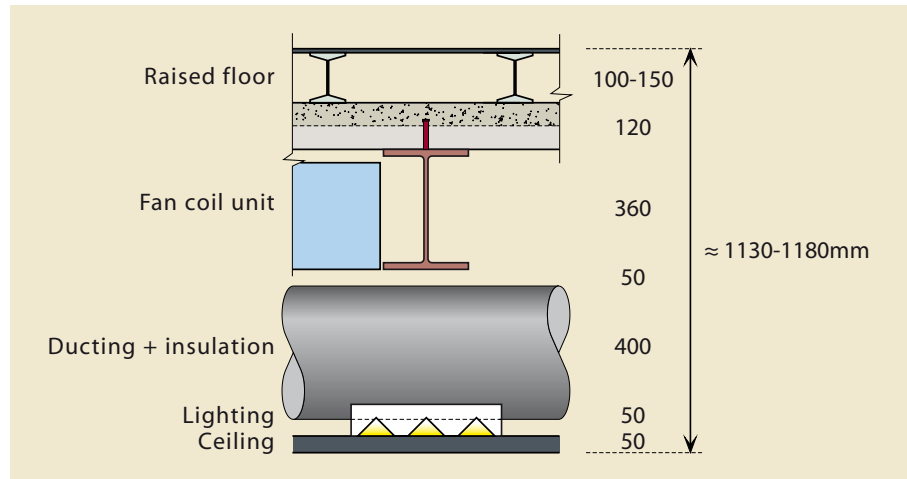

Figure 3.3 Overall floor zone ~ for services below the floor in composite construction

<b>Design approach</b>	<ol style="list-style-type: none"> <li>1. Assume secondary beams of 6 to 15 m span at 3 m spacing. Primary beams may span 2 or 3 times the secondary beam spacing, i.e. 6 to 9 m.</li> <li>2. Choose the decking and slab, using decking manufacturer's load tables or software. Use unpropped decking during construction. Ensure the chosen slab depth and reinforcement meet the fire resistance required.</li> <li>3. The orientation of the decking differs between secondary and primary beams. Use shear connectors at 300 mm centres (or to suit deck rib spacing) for secondary beams. Use 150 mm shear connector spacing for primary beams.</li> </ol>
<b>Typical section sizes</b>	<p>Beam depth <math>\approx</math> span/24 (secondary beams) or span/18 (primary beams).            Secondary beams: IPE300 for 7.5 m span and 3.75 m spacing.            Primary beams: IPE360 for 7.5 m span and 7.5 m spacing.</p>
<b>Grade of steel</b>	<p>Secondary beams and edge beams: Usually S235 or S275 steel.            Primary beams: S355 steel.</p>
<b>Overall floor zone</b>	<p>Typically, the overall floor zone is 1000 to 1200 mm for a 9 m grid with 150 mm raised floor and air conditioning ducts located below the beams.</p>
<b>Type of concrete</b>	<p>Normal weight concrete (NWC), 2400 kg/m<sup>3</sup> dry density, or light weight concrete (LWAC), 1850 kg/m<sup>3</sup> typical dry density, can be used. NWC has better sound reduction, so is used for residential buildings, hospitals, etc. LWAC is better for overall building weight/foundation design and has a longer span capability and better fire insulating properties, enabling thinner slabs (10 mm less than for NWC) to be used. It is not available in all parts of Europe.</p>
<b>Grade of concrete</b>	<p>Use C25/30 as a minimum. Use C35/45 for wearing surfaces.</p>
<b>Fire protection</b>	<p>Beams (typically):            Intumescent coating: 1.5 mm thick coating for up to 90 minutes fire resistance, or;            Board: 15 - 25 mm thick boards for up to 90 minutes fire resistance.            Columns (typically): 15 mm thick boards for up to 60 minutes, 25 mm thick boards for 90 minutes fire resistance.</p>
<b>Connections</b>	<p>Simple (non-moment resisting) connections: double angle cleats, partial depth endplates or fin plates for secondary to primary beam connections.</p>

## Integrated floor beams

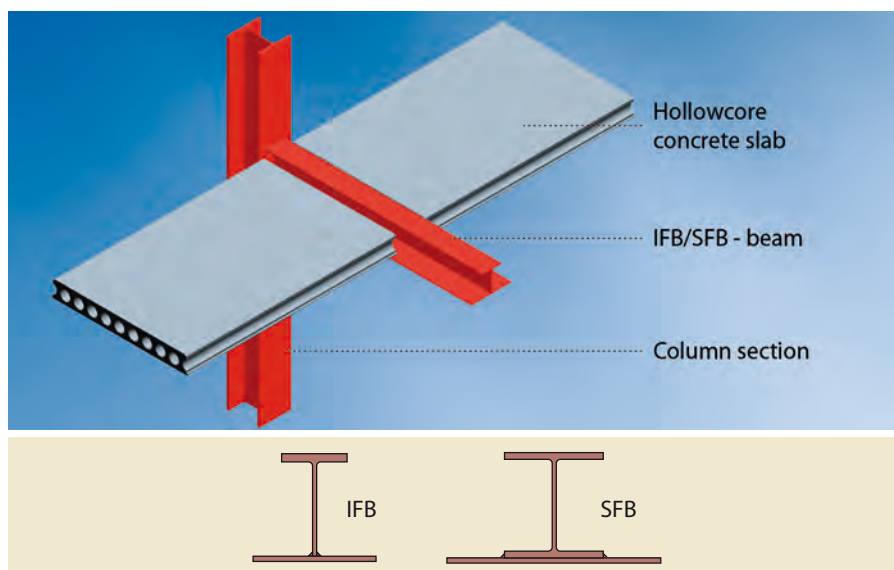

Figure 3.4 Typical integrated floor using precast concrete slab

### Description

Integrated floor beams are shallow floor systems comprising asymmetric beams supporting precast concrete elements, such as hollowcore units. The IFB system is built up by cutting an IPE or HE section into two equal T stubs and by welding a plate to the web. In the SFB system, a plate is welded underneath the lower flange of an HE or UC section, see Figure 3.4. This plate extends by at least 100 mm on each side of the beam in order to support the precast concrete units. A structural concrete topping with reinforcement is recommended to tie the precast concrete units together and to act as a diaphragm. If a topping is not provided, reinforcement should be placed through the web of the beam to tie the floor on each side in order to meet requirements for robustness and diaphragm action.

There are two options, either design the beams as a:

- non-composite section, or
- composite section - if the slab is sufficiently deep over the beams to allow for the height of shear connectors.

Beam span arrangements are normally based on a 5 - 7.5 m grid with a slab depth of 200 - 350 mm (see Figure 3.5 for guidance on spans). For integrated floor beams, the slab span is generally longer than the beam span. A range of integrated beam sections may be used between 200 and 350 mm depth depending on the concrete cover to the top of the beam (the top flange can be level with the top of the slab).

Edge beams can be either IFB/SFB sections with modified geometry or rectangular hollow section (RHS) beams, with a flange plate welded underneath. Edge beams are often designed as non-composite, and nominal shear studs are provided only for diaphragm action.

As an alternative to precast concrete units, deep steel decking may be used. This application is considered later under *Slimdek*.

Pre-design software is available free from: [www.arcelormittal.com/sections](http://www.arcelormittal.com/sections).  
Slim floor software is available from [www.corusconstruction.com](http://www.corusconstruction.com).

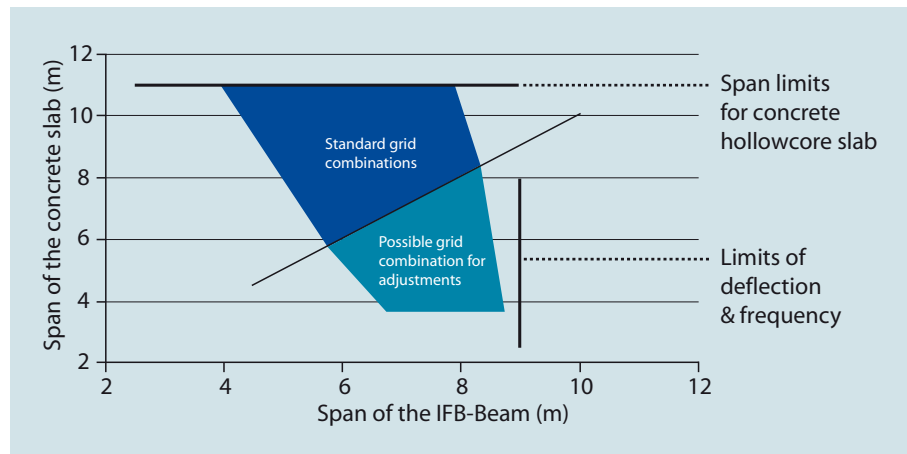

Figure 3.5 Range of application for integrated floor beams

#### Typical beam span range

5 m to 7.5 m generally, although longer spans can be achieved using deeper beams and precast concrete units. The broad range of application is presented above.

#### Main design considerations for the floor layout

For integrated beams supporting precast concrete slabs, torsional effects should be included. These effects also occur during construction. Beams loaded on one side only are relatively heavy because of combined bending and torsion, which must be considered in the beam design. A central spine beam with precast units spanning onto downstand edge beams will generally be the more economic solution, although RHS or IFB/SFB edge beams may be used to provide a shelter perimeter to the floor for highly glazed façades.

The slab depth is influenced by the concrete cover to the precast units (mainly for fire resistance), cover to the IFB/SFB and to the edge beams.

Mesh reinforcement is placed either in the concrete layer over the steel section, or if the top flange of the IFB/SFB is level with the surface of the concrete, the slabs on each side of the IFB/SFB should be tied together to meet robustness requirements. This is achieved normally by reinforcement (typically T12 bars @ 600 mm centres) passed through the web of the IFB/SFB section. IFB/SFB beams are normally designed as non-composite, although composite design can be achieved through the use of welded shear connectors.

For composite design of edge beams, U bars should be detailed around the shear connectors and embedded in the precast units or structural topping.

Detailing of connections around columns should be considered, as the IFB/SFB flanges are wider than the column and may need notching.

#### Advantages

- Beams do not normally require fire protection for up to 60 minutes fire resistance.
- Shallow floor zone - reduction in overall building height and cladding.
- Flat soffit allows easy service installation and offers flexibility of internal wall positions. Soffits can be exposed.
- Integrated floor beams can be designed as an essentially 'dry' construction system with a high level of pre-fabrication and fast installation time.

#### Services integration

Unrestricted distribution of services below the floor.



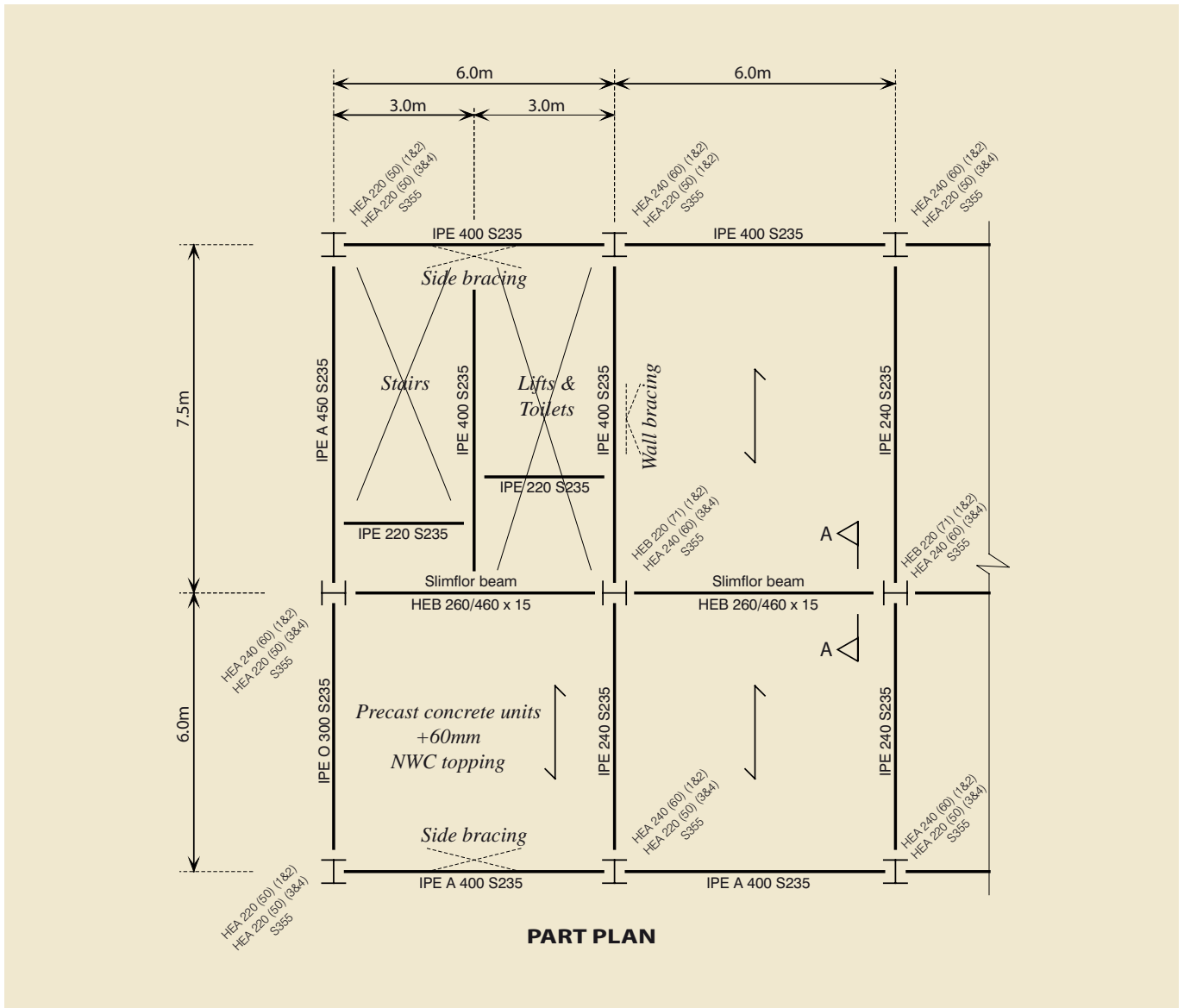

Floor zone  
 = 150mm raised floor  
 + 260mm P.C. unit & topping  
 + 150mm ceiling & lighting  
 = 560mm ≈ 600mm

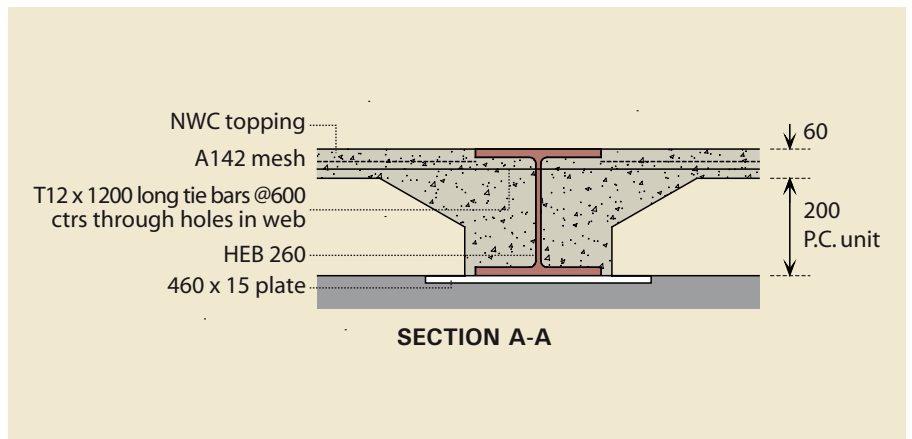

Figure 3.6 Arrangement of integrated beams and precast concrete slabs for a 4 storey rectangular plan building

**Design approach**

1. Use 6 m, 7.5 m or 9 m floor grid. The precast concrete units generally span the longer distance in a rectangular floor grid.
2. Choose the precast concrete unit from manufacturer's data. A recommended maximum span:depth ratio is 35 to achieve sufficient shear resistance of the precast units. A minimum end bearing of 75 mm for non-composite action and 60 mm for composite action is recommended. The ends of the precast concrete units are often shaped (chamfered) to allow sufficient gap for flow of concrete around the steel section.
3. Design the IFB/SFB using software. Beams may be designed either as non-composite or composite. For non-composite beams, provide ties through the beam web. For composite beams, at least 15 mm cover over the shear studs is required.
4. Design the edge beams such as RHS, IFB/SFB beams as loaded on one side, or alternatively use downstand beams. Composite edge beams require U bars which act as transverse reinforcement.

**Typical section sizes**

Beam Span	Slab span (m)	
	6 m	8 m
5 m	HEA 240	HEB 260
6 m	HEB 260	HEB 280
8 m	HEB 300	HEB 320

Table 3.1 Typical sizes of SFB beams (plus 15 mm steel plate)

Beam Span	Slab span (m)	
	6 m	8 m
5 m	1/2 IPE 500	1/2 HEB 450
6 m	1/2 HEA 450	1/2 HEA 500
8 m	1/2 HEA 600	1/2 HEB 600

Table 3.2 Typical sizes of IFB beams (plus 20 mm steel bottom flange plate)

Precast hollowcore concrete units: choose 150 mm depth for 6 m span; 200 mm depth for 7.5 m span; 260 to 300 mm depth for 9 m span. These designs provide for adequate stiffness, bending and shear resistance.

Longer span variants of integrated floor beams have been developed, such as shown in Figure 3.7 using solid bars or SHS members acting as ties below the beam. Spans of 9 to 12 m can be achieved by this form of construction.

**Grade of steel**

IFB/SFBs are available in all common steel grades steel, e.g S235 to S460.

**Overall floor zone**

600 mm with small services placed below the beams (and with a raised floor).  
1000 mm with air-conditioning ducts below the beams (and with a raised floor).

Figure 3.7 Long-span version of integrated floor beams, used in the Luxembourg Chamber of Commerce



#### Fire protection

The concrete encasement around the beam is normally sufficient to provide 60 minutes fire resistance. For 90 minutes fire resistance, an intumescent coating or board protection to the flange plate could be chosen. Careful detailing of transverse reinforcement embedded in the hollowcore units, and concrete filling of the cores adjacent to the beam, is necessary in order to satisfy structural integrity requirements in fire.

#### Connections

Integrated beams require end plate connections (typically, 6 or 8 bolted connections) to resist torsional loads acting on the beam. RHS edge beams often use extended end plate connections to provide torsional resistance.



## Cellular composite beams with composite slabs and steel decking



Figure 3.8 Long-span secondary cellular beams with regular circular openings

### Description

Cellular beams are beams with circular openings at regular spacings along their length. The beams are either fabricated from three plates, or made by cutting and re-welding tees cut from hot rolled steel sections. Openings, or 'cells', are normally circular, but can be elongated, rectangular or hexagonal. In regions of high shear, openings can easily be filled or stiffened.

Cellular beams can be arranged as long-span secondary beams, supporting the floor slab directly, or as long-span primary beams supporting other cellular beams or I section secondary beams.

Pre-design software is available free from: [www.arcelormittal.com/sections](http://www.arcelormittal.com/sections) and *Cellbeam* is available from [www.westok.co.uk](http://www.westok.co.uk).

### Typical beam span range

10 - 18 m for cellular beams designed as secondary beams.  
9 - 12 m for cellular beams as primary beams

### Main design considerations for the floor layout

Secondary beams should be spaced at 2.5 to 4 m in order to avoid propping of the decking during concreting.

Long-span primary cellular beams are less often used because they support high shear forces and their design is therefore inefficient unless the web thickness is increased or opening sizes are reduced.

Large (elongated or rectangular) openings should be located in areas of low shear, e.g. in the middle third of the span for uniformly loaded beams.

### Advantages

- Long-spans with efficient use of steel.
- Relatively lightweight beams, compared to other long-span systems.
- Services can be integrated within the floor zone, leading to reductions in overall building height.
- Pre-camber can be introduced during fabrication to reduce visible deflections.

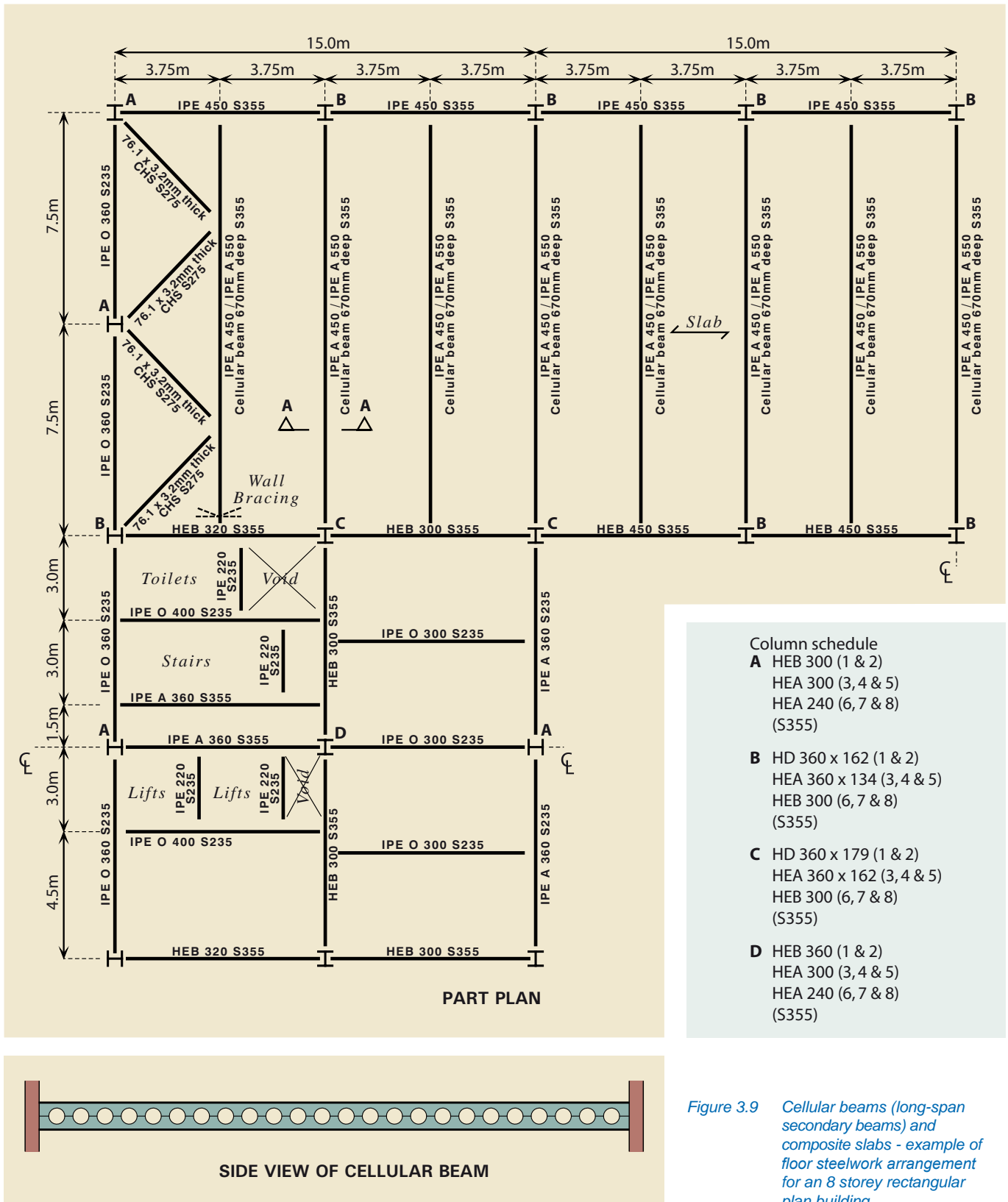

Column schedule

<b>A</b>	HEB 300 (1 & 2)
	HEA 300 (3, 4 & 5)
	HEA 240 (6, 7 & 8)
	(S355)
<b>B</b>	HD 360 x 162 (1 & 2)
	HEA 360 x 134 (3, 4 & 5)
	HEB 300 (6, 7 & 8)
	(S355)
<b>C</b>	HD 360 x 179 (1 & 2)
	HEA 360 x 162 (3, 4 & 5)
	HEB 300 (6, 7 & 8)
	(S355)
<b>D</b>	HEB 360 (1 & 2)
	HEA 300 (3, 4 & 5)
	HEA 240 (6, 7 & 8)
	(S355)

Figure 3.9 Cellular beams (long-span secondary beams) and composite slabs - example of floor steelwork arrangement for an 8 storey rectangular plan building

<b>Services integration</b>	Regular openings in the web allow circular ducts to pass through the beams, as shown in Figure 3.10. Opening diameters can be chosen, depending on the services requirements and should allow for insulation around the services. Web openings should be aligned through the beams along the building in order to permit freedom of servicing.
<b>Design approach</b>	<ol style="list-style-type: none"> <li>1. Use cellular beams as long-span secondary beams at 3 to 4 m spacing, in a rectangular column grid with primary beams at a spacing of 2 or 3 times the secondary beam spacing.</li> <li>2. Choose the decking and slab, using decking manufacturer's load tables or software. Choose the slab depth and reinforcement to meet the fire resistance required.</li> <li>3. Design the cellular beams using manufacturer's software. The opening diameter should be in the range 60 to 80% of the beam depth. Elongated openings may require additional horizontal stiffeners. Opening sizes and positions should be agreed with the services engineer.</li> </ol>
<b>Typical section sizes</b>	Cellular beam depth $\approx$ span/22; for example, a 700 mm deep cellular beam is required for a 15 m span.
<b>Grade of steel</b>	S355 is preferred for cellular beams because of the local high stress effects around the openings.
<b>Overall floor zone</b>	1000 to 1200 mm depth. For example, 1050 mm for 15 m span cellular beams with regular 400 mm openings, as shown in Figure 3.10.
<b>Fire protection</b>	Intumescent coating of 1.5 to 2 mm thickness may be applied on-site, but off-site application can also be cost-effective. Additional fire protection may be required, as the section factor of the cellular cross-section is higher than that of the equivalent steel profile.

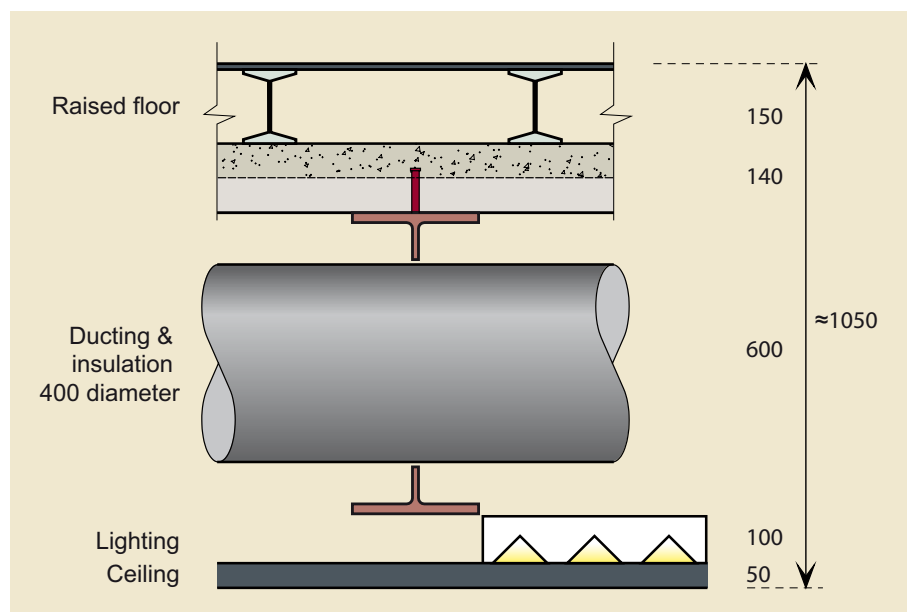

Figure 3.10 Cellular beam - Typical cross-section showing services integration

## Long-span composite beams with web openings

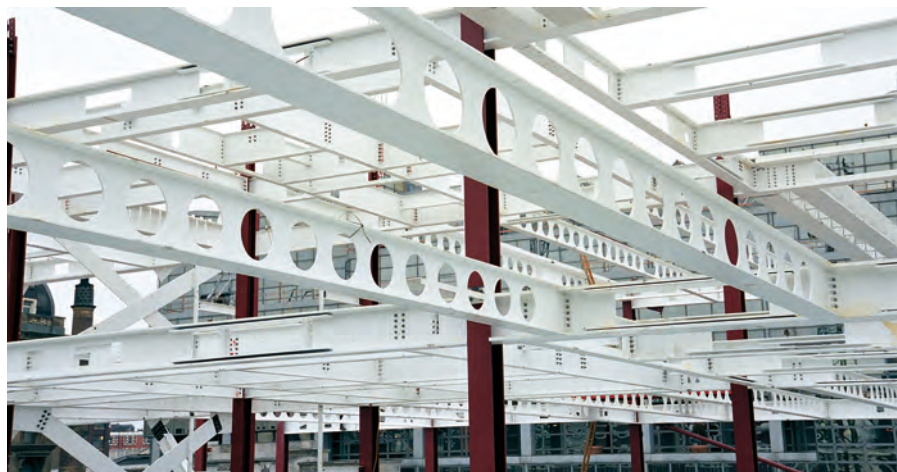

Figure 3.11 Hot rolled beams with off-site fire protection

<b>Description</b>	<p>This system consists of composite beams using either rolled or fabricated sections supporting a composite slab in a long-span arrangement of, typically, 12 to 18 m span. Two possible floor grids are: long-span secondary beams, supported by short span primary beams, or short span secondary beams supported by long-span primary beams.</p> <p>The depth of the long-span beams means that service openings, if required, can be provided in the web of the beam. Openings can be circular, elongated or rectangular in shape, and are 60 to 80% of the beam depth. Web stiffeners may be required around large openings.</p>
<b>Typical beam span range</b>	<p>Long-span secondary beams: 9 m to 15 m span at 3 to 4 m spacing. Long-span primary beams: 9 m to 12 m span at 6 to 9 m spacing.</p>
<b>Main design considerations for the floor layout</b>	<p>Secondary beams should be located at 3 to 4 m spacing to avoid propping the decking during construction. Large (elongated or rectangular) openings should be located in areas of low shear, e.g. in middle third of the span for uniformly loaded beams.</p>
<b>Advantages</b>	<ul style="list-style-type: none"> <li>• Long column-free areas by maximising beam spans.</li> <li>• Section sizes can be chosen with respect to the applied loading and services requirement.</li> <li>• Reduction of the overall floor height due to services integration and consequently reduction of the overall building height.</li> </ul>
<b>Services integration</b>	<p>Service ducts pass through openings in the web of the beams. Larger service units and ducts can be placed between the beams.</p>
<b>Design approach</b>	<ol style="list-style-type: none"> <li>1. Use long-span secondary beams at 3 to 4 m spacing, and primary beams of 6 m to 9 m span. Alternatively, use long-span primary beams and 6 or 7.5 m span secondary beams.</li> <li>2. Choose the decking and slab, using a decking manufacturer's load tables or software, taking account of fire resistance.</li> <li>3. Design beams using available software. Select the sizes and positions of openings in the web, and allow for insulation around the services.</li> </ol>
<b>Typical section sizes</b>	<p>Depth of beam <math>\approx</math> span/15 to span/22 using asymmetric sections.</p>



<b>Grade of steel</b>	S275 for beams controlled by deflection, or S355 for highly perforated beams.
<b>Overall floor zone</b>	1000 mm for 13.5 m span (with 350 mm deep web openings). 1100 mm for 15 m span (with 400 mm deep web openings).
<b>Fire protection</b>	Boards or intumescent coatings. Intumescent coatings can be applied off-site as a single coating up to 1.8 mm thick to achieve 90 minutes fire resistance.

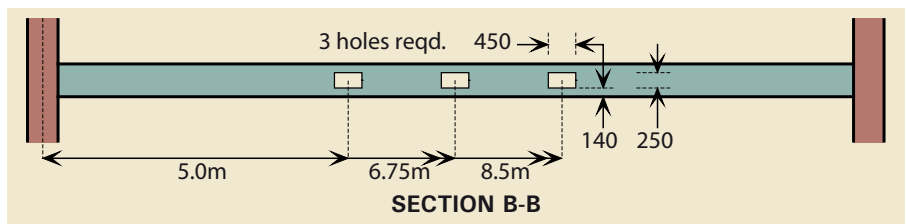
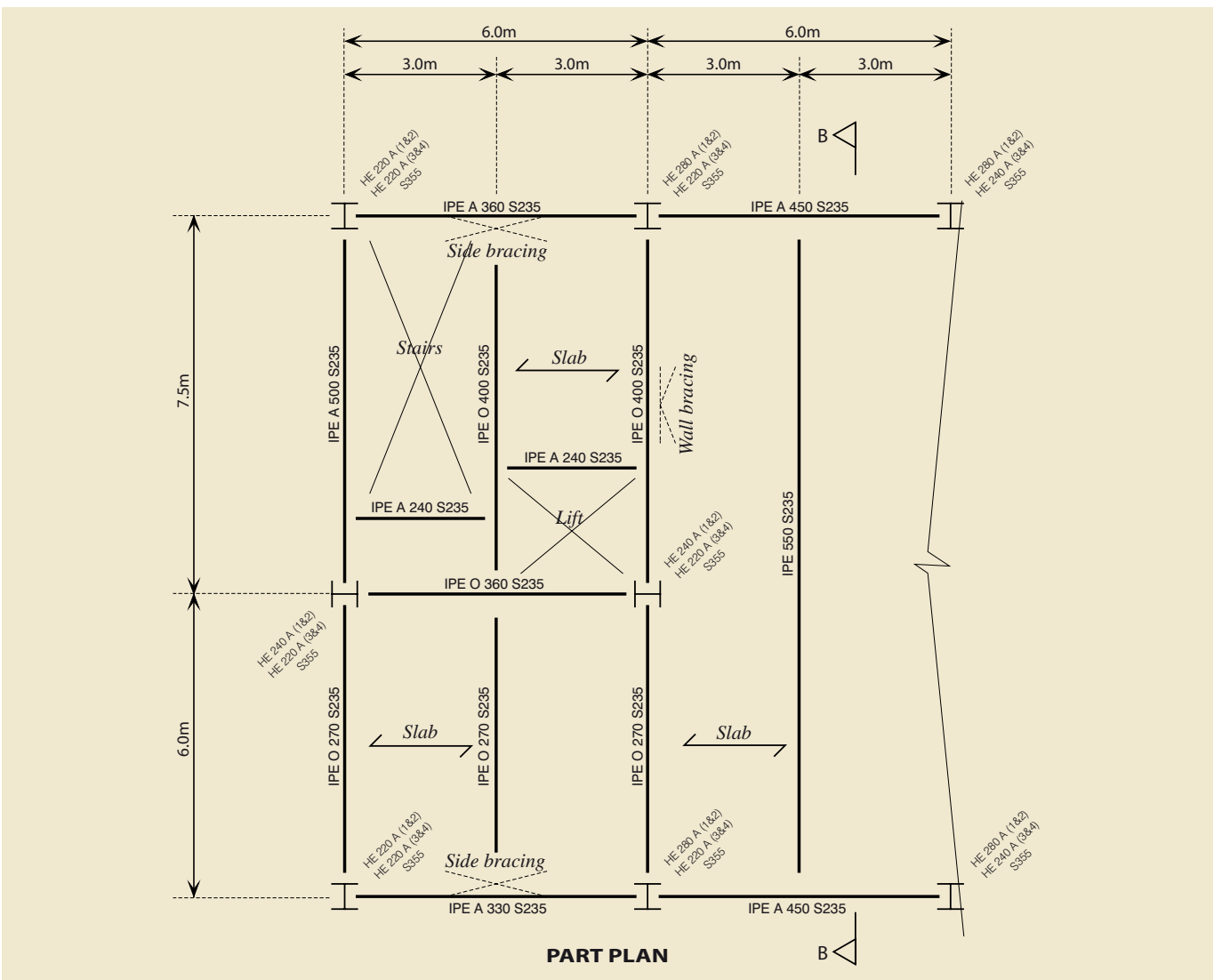

Figure 3.12 Long-span composite beams (with rectangular web openings)

## Composite beams with precast concrete units



Figure 3.13 Composite floor construction with precast concrete hollowcore units and cellular beams

### Description

This system consists of steel beams with shear connectors welded to the top flange. The beams support precast concrete units, with a structural concrete infill placed over the beam between the ends of the units, and generally with an additional topping covering the units (which is recommended). The precast units are in the form of either hollowcore slabs, normally of 150 to 260 mm depth, or solid planks of 40 mm to 100 mm depth. Sufficient flange widths are required to provide a safe bearing length for the precast units and sufficient gap for effective action of the shear studs.

Deeper precast units are either chamfered on their upper face or notched to allow a thicker topping depth to fully encase the shear connectors. Narrow channels are created within the units during the manufacturing process to allow transverse reinforcement to be placed across the beams and to be embedded in the precast units. For this reason, the minimum width of the top flange is 180 to 210 mm.

Pre-design software is available free from: [www.arcelormittal.com/sections](http://www.arcelormittal.com/sections).

### Typical beam span range

10-18 m beam span and 3-9 m span of the precast concrete units, depending on their depth and form. Precast hollowcore units have longer spans than solid precast slabs.

**Main design considerations for the floor layout**

Precast hollowcore units span typically 6 to 9 m. Precast planks of 3 to 4 m span may also be used. The beams must provide sufficient minimum width to support the precast concrete units (200 mm is a sensible minimum beam width - see below).

Edge beams are normally designed as non-composite, but tied into the floor to meet robustness requirements. For composite design, the shear connectors require U bars at the slab edge.

The beams are designed for torsional loading during construction, when it is assumed that the present concrete units are placed on one side of the beam. This may dictate the minimum beam size.

Temporary bracing to provide lateral restraint is often required to reduce the effective length for lateral torsional buckling of the beam during the construction stage, particularly when only one side is loaded.

**Advantages**

- Fewer secondary beams, when long-span precast units are used.
- Shear connectors can be welded off-site, enabling larger stud diameters to be used and requiring fewer site operations.

**Services integration**

Main service ducts are located below the beam with larger services equipment, such as Fan Coil Units, located between the beams.

**Design approach**

1. Use a 6, 7.5 or 9 m grid for this system with beam spans up to 18 m.
2. Choose precast concrete units from manufacturer's data for the required fire resistance.
3. Select the beam size based on the requirements for end bearing and composite design.

Minimum flange width for bearing	Minimum beam widths
40 to 100 mm deep solid slab	Internal beam - 180 mm Edge beam - 210 mm
150 to 250 mm deep hollowcore unit	Internal beam - 180 mm Edge beam - 210 mm
Non-composite beam	Edge beam - 120 mm (minimum)

5. Design the composite beams taking account of the degree of shear connection provided. Typical reinforcement details are shown in Figure 3.14.
6. Design the edge beams as non-composite.

**Typical section sizes**

Beams: Typical section size is IPE 450 to IPE 800 for use with precast units delivered with chamfered ends and welded shear connectors. HE or UC sections may also be used.

Hollowcore Unit Depth (mm)	Span (m)	Imposed Load (kN/m <sup>2</sup> )
150 mm	6	3.5
200 mm	7.5	3.5
250 mm	9	5.0

Table 3.3 Typical spans of hollowcore concrete units

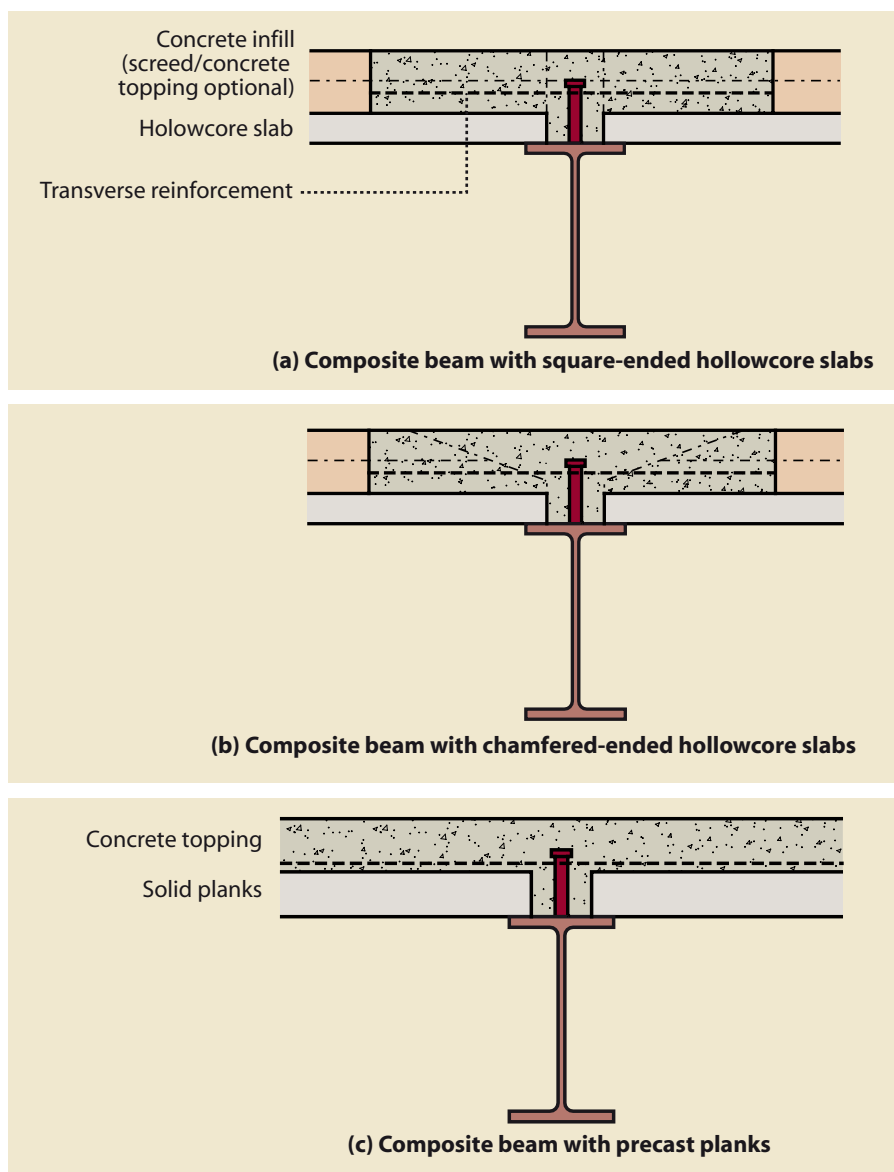

Figure 3.14 Forms of composite beams with precast units

<b>Grade of steel</b>	S235 to S460, depending on control of deflections.
<b>Overall floor zone</b>	900 mm, including ceiling beam and slab for a span of 9 m, plus the zone required for services through or below the beam.
<b>Fire protection</b>	<p>Spray, board or intumescent coating to beam or partially encased beams.</p> <p>For integrity in the fire condition, transverse bars must be detailed and embedded into the precast hollowcore units and extended at least 600 mm into each unit (see Figure 3.14). For 90 or 120 minutes fire resistance, a 50 mm (minimum) concrete topping is also required.</p>
<b>Connections</b>	Full depth end plate connections (welded to the beam flanges) to resist torsional loading.



## Non-composite beams with precast units



Figure 3.15 Precast concrete units placed on non-composite beams

<p><b>Description</b></p>	<p>Precast units may be supported on the top flange of the steel beams or on 'shelf' angles. Shelf angles are bolted or welded to the beam web, with an outstand leg long enough to provide adequate bearing of the precast unit and to aid positioning of the units. The units may have a screed (which may be structural), or may have a raised access floor. The precast units may be in the form of hollowcore slabs or solid planks of 75 mm to 100 mm depth.</p> <p>Pre-design software is available free from: <a href="http://www.arcelormittal.com/sections">www.arcelormittal.com/sections</a>.</p>
<p><b>Typical beam span range</b></p>	<p>6 m and 7.5 m spans are common for both the beams and precast units. However the span of the slab will be shorter where precast planks are used.</p>
<p><b>Main design considerations for the floor layout</b></p>	<p>Construction stage loading (for precast planks on one side only) must be considered.</p> <p>Temporary lateral bracing is often required to limit the effective length for lateral torsional buckling of the beam during the construction stage when only one side is loaded.</p> <p>Beams loaded on one side only in the permanent condition should preferably be avoided, or designed for the applied torsional moment.</p>
<p><b>Advantages</b></p>	<p>Essentially a dry construction system, where beam depth is not critical.</p>
<p><b>Services integration</b></p>	<p>Main service ducts are located below the beams, with larger services located between beams.</p>

<b>Design approach</b>	<ol style="list-style-type: none"> <li>1. Use a 6 m or 7.5 m grid using 150 mm deep precast units for 6 m span and 200 mm deep for 7.5 m span.</li> <li>2. Choose precast concrete units from manufacturer's data to meet the required fire resistance.</li> <li>3. Design the steel beams using software, or by simple manual calculation. Take account of torsional effects during installation.</li> <li>4. Check the temporary construction condition, and consider temporary bracing.</li> </ol>
<b>Typical section sizes</b>	<p>Beam depth <math>\approx</math> span/15.</p> <p>When the top flange of a beam supports precast planks, the minimum flange width is 180 mm to allow for minimum bearing and a 30 mm gap between the precast concrete units.</p> <p>The minimum beam size is IPE 400 when supporting precast planks on the top flange.</p> <p>When shelf angles are provided, 25 mm clearance is required between the end of the concrete unit and the beam flange, as shown in Figure 3.17. Shelf angles should project at least 50 mm beyond the beam flange.</p>
<b>Grade of steel</b>	S235 to S460, depending on control of deflections.
<b>Overall floor zone</b>	For a 7.5 m grid, the overall floor zone is approximately 800 mm, including a suspended ceiling.

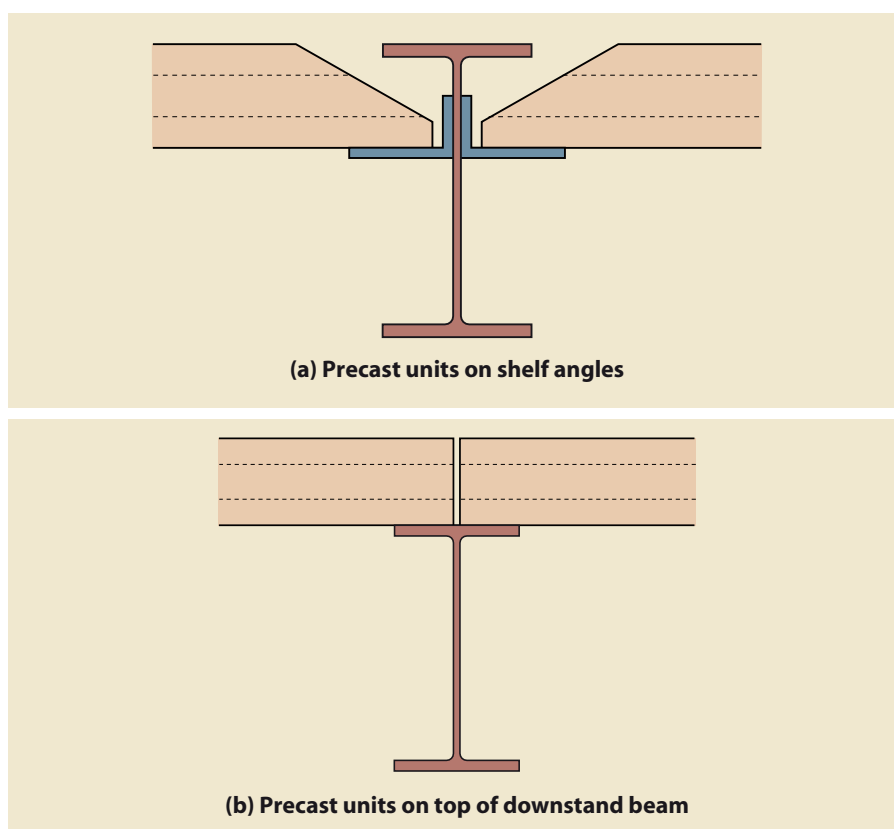

Figure 3.16 Floor construction with precast concrete units in non-composite construction

**Fire protection**

Fire protection can be provided by spray, board or intumescent coating to the beams. Shelf angle beams can achieve 30 minutes fire resistance by turning up the angles so that the upper leg of the angle remains relatively cool in fire.

**Connections**

Full depth end plate connections (welded to the beam flanges) are required, as the beams resist torsional loads in the construction condition.

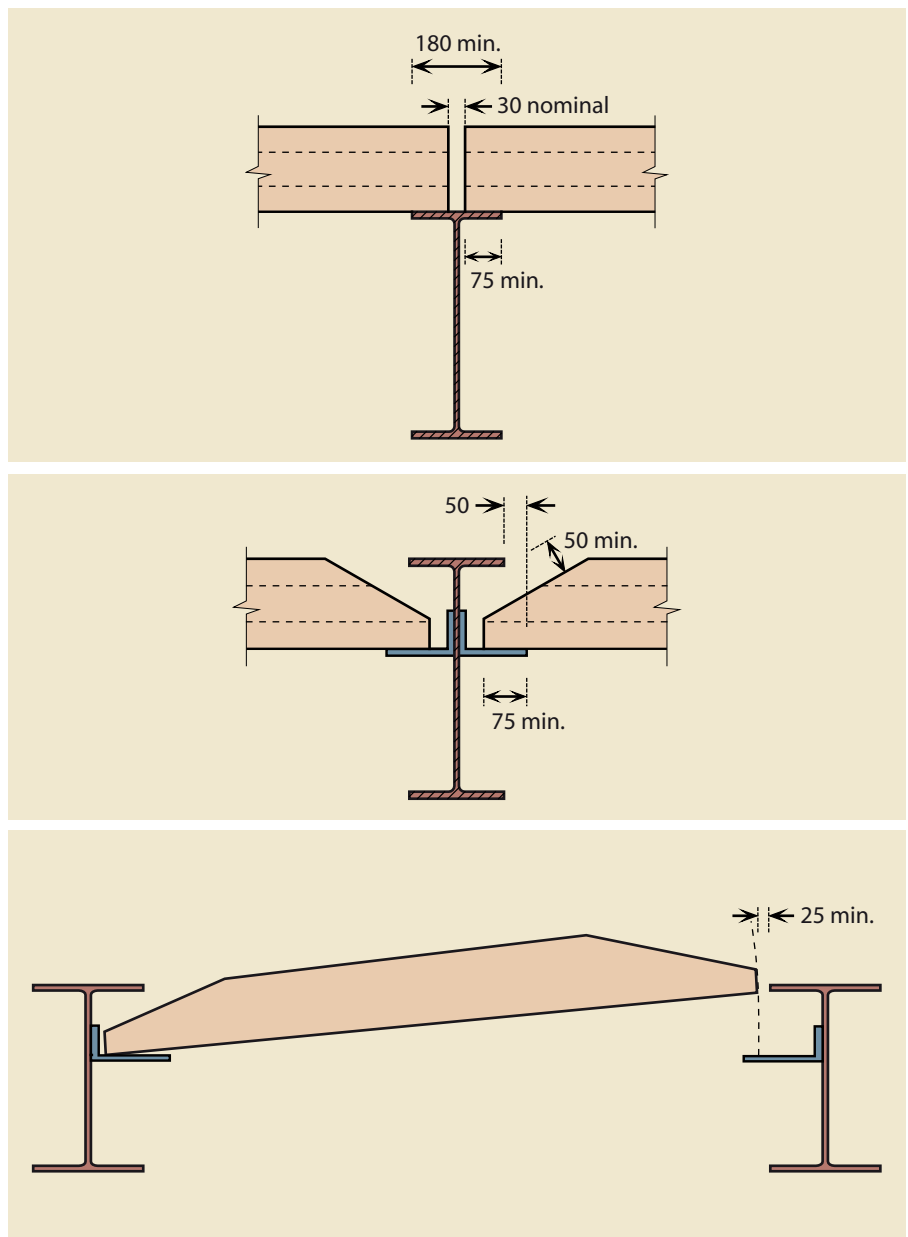

Figure 3.17 Bearing and clearance requirements for precast units

# 04 Special Floor Systems

**This section reviews the use of specialist flooring systems that are unique to one supplier, but have established strong market use in various sectors and in certain European countries.**

These flooring systems are:

- *Cofradal* (by ArcelorMittal).
- *Hoesch Additive Floor*<sup>®</sup> (by ThyssenKrupp).
- *Slimline* (by Slimline Buildings).
- *Slimdek* (by Corus).

A range of fabricated steel sections has been developed for use in composite construction and for integrated (slim floor) beams, which were covered earlier in Section 3. They are essentially generic products available from a range of manufacturers.

The supplier of these special flooring systems can provide detailed design information and software for their products.

*Cofradal 200*

*Hoesch Additive Floor*<sup>®</sup>

*Slimline system*

*Slimdek*



## Cofradal 200

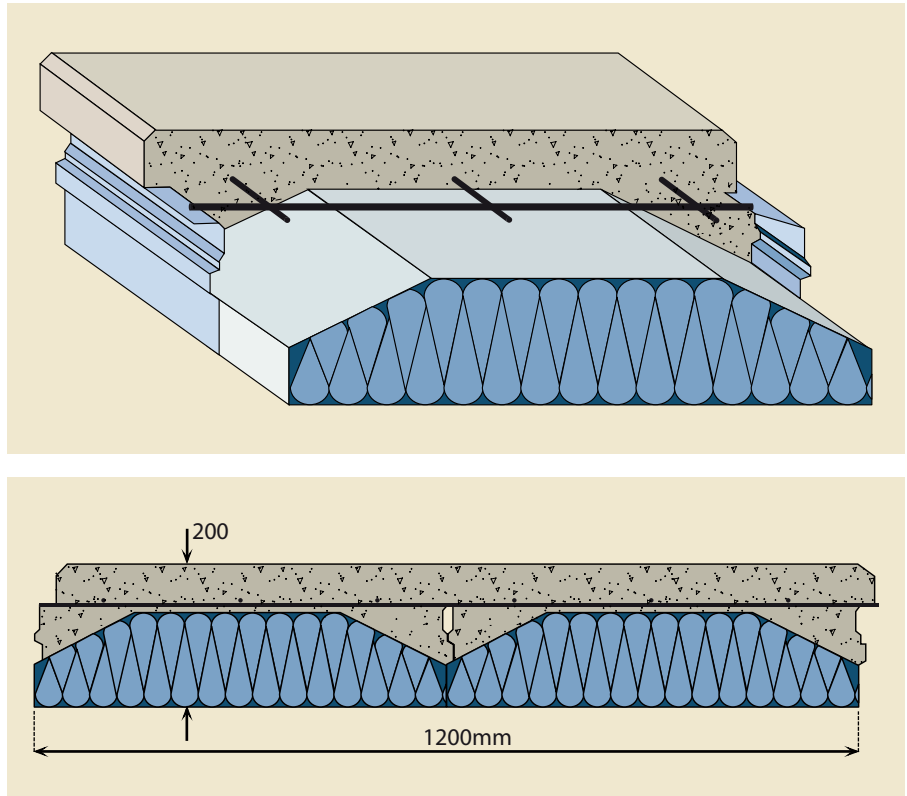

Figure 4.1 View and cross-section of a Cofradal slab unit

### Description

*Cofradal 200* is an innovative pre-fabricated floor slab system that is suitable for light industrial and office buildings, and also for residential buildings. The slab units are 600 mm wide and the floor is typically 200 mm deep.

The system comprises pre-fabricated composite steel/concrete slab units that are factory produced. The elements have a steel soffit and concrete topping. Only a small amount of concreting is needed to embed the support perimeter joint area and to place an additional light concrete topping on the floor. There is no need for temporary propping on-site during construction.

*Cofradal 200* is based on the use of galvanized profiled steel sheeting infilled with mineral wool. The mineral wool provides for thermal insulation between floors, if needed, acoustic resistance, and a fire resistance of up to 120 minutes.

The profiled steel sheeting acts in tension as part of a composite floor system. Special profiled forming is provided on both longitudinal edges to allow for fitting and shear connection between two adjacent floor elements. The high density mineral wool provides effective shuttering for the concrete placed above it. Mesh reinforcement is placed in the concrete topping, as illustrated in Figure 4.1.



Figure 4.2 Delivery of Cofradal 200 to site

#### Main design considerations

A normal concrete C25/30 topping is strengthened with reinforcing bars welded on to the steel sheeting. This provides connection between the steel and the concrete, leading to good composite behaviour.

The construction depth is 200 mm and the slab weight is 2 kN/m<sup>2</sup>. The panel width is 600 mm, but a width of 1200 mm can also be provided. The slab is between half and one third the weight of an equivalent flat concrete slab.

It can also be used for ground slabs provided that air circulation is effective and moisture is avoided beneath the slab.

The performance of the slab is adequate for an imposed load of 3 kN/m<sup>2</sup> for a 7.5 m span or an imposed load of 8 kN/m<sup>2</sup> for 2.5 m span. The controlling factor is the fire resistance of the slabs.

The acoustic insulation of the floor is:

$R_w(C, C_{tr}) = 58 \text{ dB}$ ,  $L_{n,w} = 78 \text{ dB}$  for the Cofradal slab alone and

$R_w(C, C_{tr}) = 64 \text{ dB}$ ,  $L_{n,w} = 66 \text{ dB}$  for the slab with a suspended ceiling.

#### Advantages

- Essentially a 'dry' pre-fabricated construction technology.
- Long-span system, which competes with hollowcore slabs.
- Excellent acoustic insulation.
- Lightweight construction system in comparison to reinforced concrete.



Figure 4.3 View of the Cofradal slab before concreting



Figure 4.4 Under-side view of the finished Cofradal slab. A suspended ceiling is provided for services

## Hoesch Additive Floor®

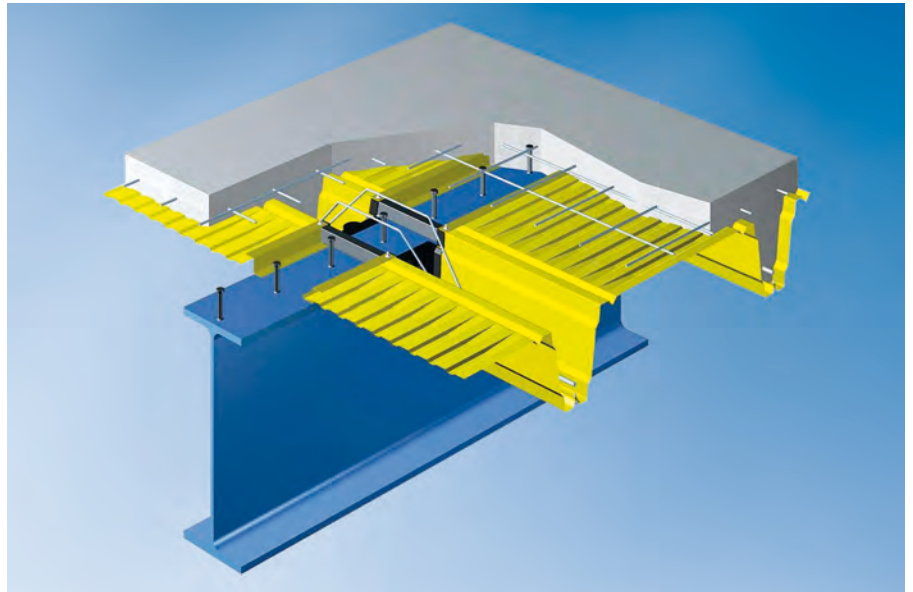

Figure 4.5 Principal details of the Hoesch Additive Floor®

### Description

The *Hoesch Additive Floor*® is a floor system that is commonly used in car parks and has recently also been used in multi-storey commercial buildings. The floor comprises 200 mm deep steel decking with bar reinforcement and a concrete topping.

The steel decking is positioned between the flanges of the beams, so that the floor height is significantly reduced. The deck panels are supported by special steel blocks welded onto the upper flange of the beams, and the deck is fixed with shot fired fasteners onto the blocks.

Any type of composite beam construction can be chosen, e.g. hot rolled I sections, cellular beams, etc., using primary and secondary beams or only primary beams. The concrete topping to the slab is chosen to achieve the required depth for composite action of the beams.

The steel decking and the concrete are not designed to act as a composite slab. The beam itself can be designed as a composite structure, in which case shear connectors are provided on the flange of the I section, as shown in Figure 4.5. The slab spans between the beams, which leads to flexibility in arranging the shear studs on the beam flange.

### Main design considerations for the floor layout

Decking has to be propped for spans over 5.5 m, which leads to maximum beam grids of 5.8 m. The slab depth is influenced by concrete cover to the decking (minimum 80 mm, depending on required depth for composite action with the beams). The grid is usually based on a multiple of 750 mm, which is the spacing between the deck ribs. For longer deck spans, the slab should be concreted in two stages rather than being temporarily propped, thus increasing the possible spans up to 7 m.



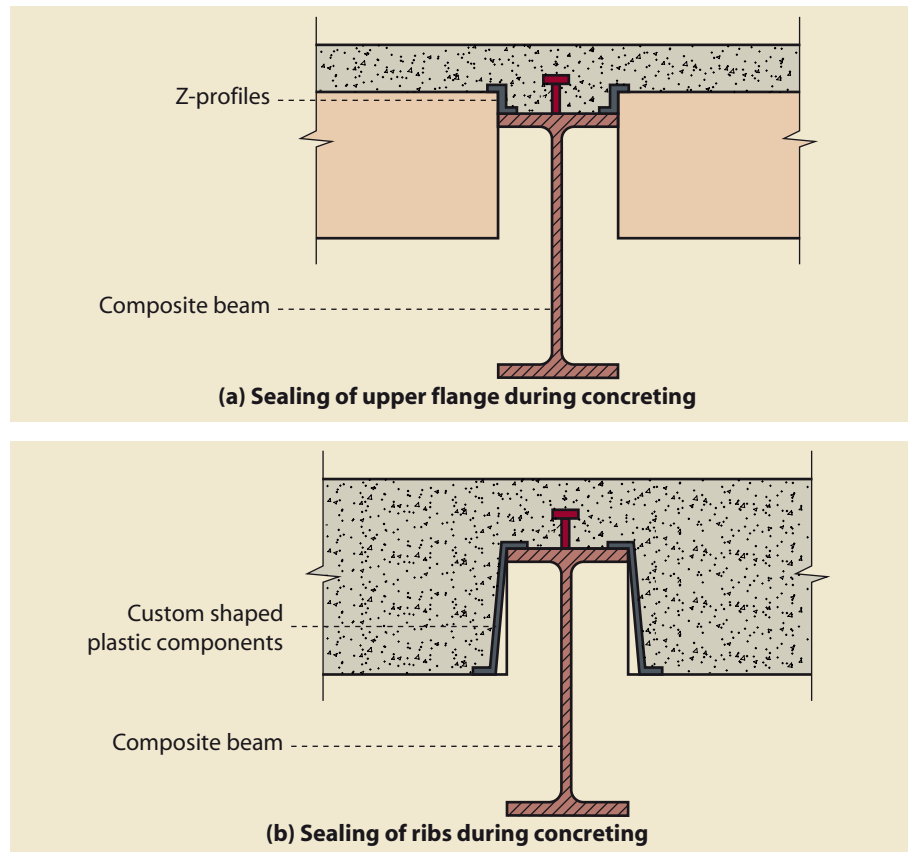

Figure 4.6 Selected details of the Hoesch Additive Floor®

<b>Advantages</b>	<ul style="list-style-type: none"> <li>• Slab spans up to 5.5 m without propping in the construction stage.</li> <li>• Comparatively low self weight of the slab.</li> <li>• The slab does not affect the composite action of the beams (shear studs can be arranged as required).</li> <li>• Reduced floor height by placing the steel decking between the beams.</li> <li>• Steel decking provides restraint to prevent lateral torsional buckling of the beams during construction.</li> </ul>
<b>Services integration</b>	Unrestricted distribution of services below the floor. Small services can be passed in the ribs of the steel decking and then through holes in the web of the beams.
<b>Typical section sizes</b>	Design as a composite beam, using the guidance in Section 3.
<b>Grade of steel</b>	S235 or S275 steel is preferred for the beams. Steel decking: S350 GD.
<b>Overall floor zone</b>	Slab depth of 205 mm plus the concrete cover to the beam (minimum 80 mm, depending on the required depth for composite action of the beams). Overall floor zone depends on sections used for beams and services integration (see previous Sections).
<b>Fire protection</b>	For the slab, 90 minutes fire resistance can be achieved with additional reinforcement. Additional fire protection to the steel beams is required.

## Slimline system

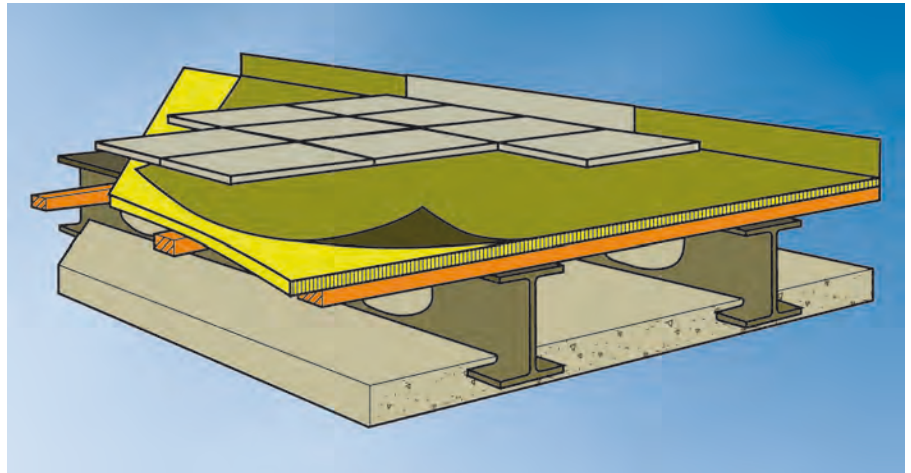

Figure 4.7 Details of the Slimline system

### Description

The Dutch company Slimline Buildings has developed a pre-fabricated concrete slab floor system called *Slimline* which consists of parallel steel beams embedded in a soffit slab and a (removable) top floor. The slab is exposed on its underside. The objective is to separate the structural elements from the services and offer increased flexibility in the design and functionality of buildings at reduced construction costs. The company interacts with the manufacturers of the pre-fabricated concrete elements and provides contractors/licensees of turnkey projects.

This system provides for easy services distribution and has shown to be cost-effective compared to traditional building methods (according to a study carried out by the Dutch Association of Cost Engineers).

Pre-design software will be available by the end of 2008 from:  
[www.slimlinebuildings.com](http://www.slimlinebuildings.com)

### Typical beam span range

- Pre-fabricated *Slimline* system (acting as secondary beams): 4.5 to 9.6 m.
- Main beam span: 6 to 12 m, which supports the *Slimline* beams.
- Standard height according to maximum span: 275 mm for 4.50 m, 295 mm for 5.4 m, 355 mm for 7.2 m and 445 mm for 9.6 m spans respectively.
- Standard pre-fabricated unit width of 2400 mm for transportation.

<b>Main design considerations for the floor layout</b>	<p>Steel beam connected by a concrete slab on its lower side.</p> <ul style="list-style-type: none"> <li>• <i>Self weight</i>: Typically 1.60 kN/m<sup>2</sup> (excluding the upper cover slab).</li> <li>• <i>Vibration</i>: Measurements on existing buildings have shown that the minimum natural frequency exceeds 7 Hz.</li> <li>• <i>Acoustic properties</i>: The <i>Slimline</i> floor and the floor materials form a two piece construction that satisfies the functional requirements for offices and residential buildings.</li> <li>• <i>Thermal capacity</i>: As there is no ceiling, the concrete provides thermal capacity to regulate internal temperature.</li> <li>• Can be used as ground slabs with insulation on the bottom, e.g. 80 mm Expanded Polystyrene (EPS), <math>R_c = 2.52 \text{ m}^2\text{K/W}</math>. This includes the thermal resistance produced by the two-piece construction.</li> </ul>
<b>Advantages</b>	<ul style="list-style-type: none"> <li>• Dry construction system onsite.</li> <li>• Reduction of storey height as no suspended ceiling required.</li> <li>• Easy services installation and maintenance.</li> <li>• Longer span system than achievable in concrete.</li> <li>• Thermal capacity can be mobilized to regulate internal temperatures.</li> </ul>
<b>Services integration</b>	The main advantages of this type of floor are its flexibility, because of the easy access to the services from the floor above.
<b>Typical section sizes</b>	IPE 240 to 360, typically for spans of 5 to 8 m.
<b>Grade of steel</b>	S235 typically, as design is governed by deflections.
<b>Type of concrete</b>	Concrete typically: C25/30 in normal weight concrete.
<b>Overall floor zone</b>	Typically, 300 to 500 mm, excluding the primary beams which support the <i>Slimline</i> flooring system.
<b>Fire protection</b>	Concrete floor: The <i>Slimline</i> floor achieves fire resistance of 90 minutes in accordance with the Bouwbesluit (Dutch Building Regulations).
<b>Connections</b>	The <i>Slimline</i> units are placed directly on or attached to the side of the support (primary) beams. In the former case, the slab is cast short of the support beam so that the connections are made to the flange of the supporting beam.

## Slimdek



Figure 4.8 Service distribution below the floor in Slimdek

### Description

*Slimdek* is a shallow floor system comprising asymmetric beams (ASB) supporting composite slabs using deep decking and is available from Corus. ASBs are hot rolled steel beams with a wider bottom flange than top. The section has embossments rolled into the top flange and acts compositely with the concrete encasement without the need for additional shear connectors. The decking spans between the bottom flanges of the beams and supports the slab and other loads during construction.

Span arrangements are normally based on a 6 to 9 m grid, with a slab depth of 280 - 350 mm. The deep decking requires propping during the construction stage for spans longer than 6 m.

A range of ASB sections is available in each of two serial sizes of 280 and 300 mm depth. Within this range, there are five ASBs with relatively thin webs and five ASB(FE) (fire engineered) sections with relatively thick webs (equal to or thicker than the flanges). The ASB(FE) sections provide a fire resistance of 60 minutes without additional protection in this form of construction for normal office loading.

Services can be integrated by forming elongated openings in the webs of the beams, and by locating ducts between the ribs of the decking, as illustrated in Figure 4.9.

Edge beams can be in the form of RHS *Slimflor* beams, which comprise a rectangular rolled hollow section (RHS) with a flange plate welded underneath, ASBs or downstand beams. Ties, normally in the form of Tees with the leg cast in the slab, are used to restrain the columns internally in the direction at right angles to the main beams.

### Typical beam span range

6 to 7.5 m grids, typically, although 9 x 9 m grid is possible.

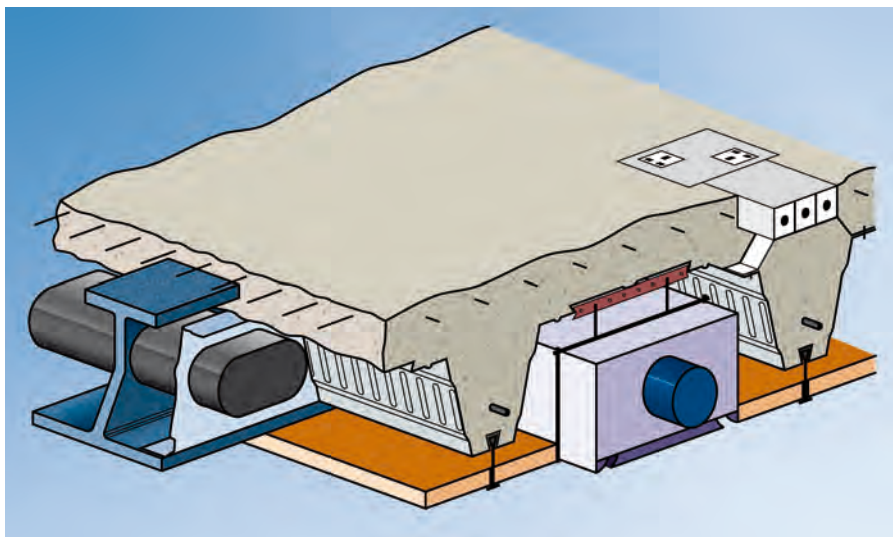

Figure 4.9 Integration of services within Slimdek floors

#### Main design considerations for the floor layout

- A central spine of ASBs with decking spanning onto edge beams will generally be more economic than a series of transverse ASBs for buildings of rectangular plan shape. Torsion may govern beam design at a change in direction of floor span and for edge beams. RHS *Slimflor* beams resist torsional loading effectively.
- Decking requires propping for spans over 6 m (propped twice for 9 m span).
- Slab depth is influenced by the concrete cover to the deck (mainly for fire resistance), cover to the ASB (30 mm minimum), and cover to the edge beam. ASBs are designed as non-composite if the cover is less than 30 mm.
- Detailing of connections around columns should be considered, as the ASB flanges are wider than the column and may need notching.
- *Slimdek* flooring can be designed using the *Slimdek* suite of software.

Further information is available at: [www.steel-sci.org](http://www.steel-sci.org).

#### Advantages

- Shallow floor zone - leading to a reduction in overall building height and cladding costs. The virtually flat soffit facilitates service installation and offers flexibility of internal wall positions.
- Inherent 60 minutes fire resistance with no additional protection.
- Regular openings can be provided between the deck ribs for services.

#### Services integration

Unrestricted distribution of services below the floor. Small services and ducts (up to 160 mm diameter) can be passed through holes in the beam web and between the deck ribs.



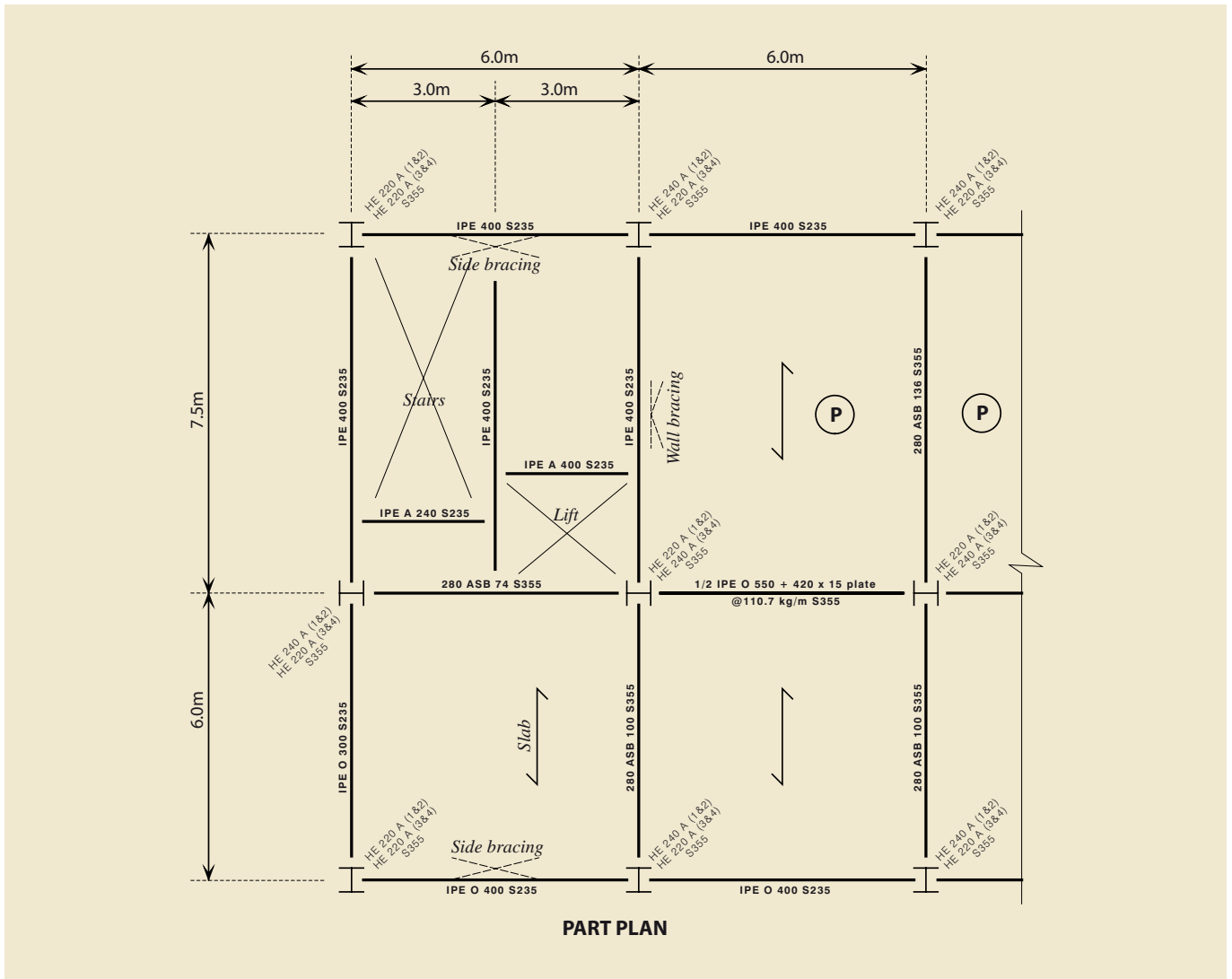

**P** = decking requires propping during construction in this span

Figure 4.10 (Above) Slimdek - floor steelwork arrangement for a 4 storey rectangular building (central spine ASB and downstand edge beams)

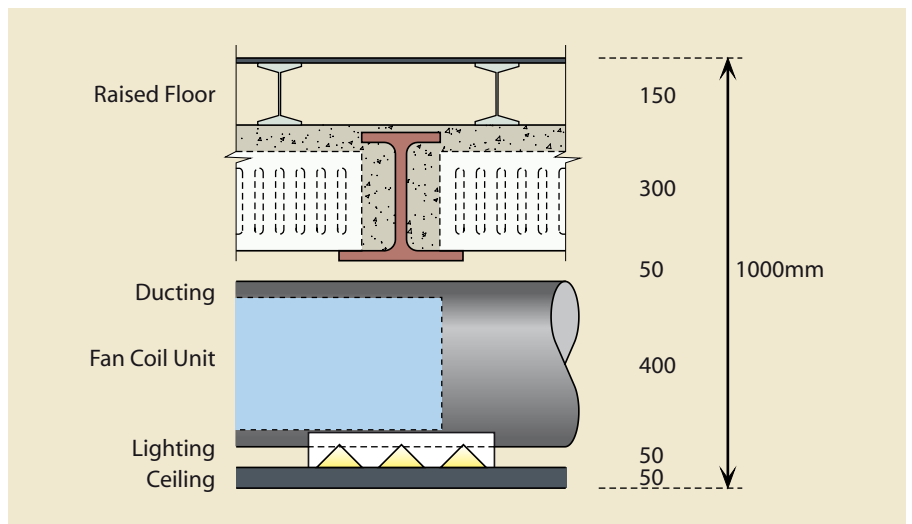

Figure 4.11 (Right) Slimdek - typical cross-section with air conditioning units below the slab

**Design approach**

1. Assume beams are located on a 6 m, 7.5 m or 9 m grid. (Note that decking spans over 6 m require temporary propping, which may affect the construction programme.)
2. Choose the decking and design the slab. Ensure the chosen slab depth and reinforcement meet the fire resistance required.
3. Design the ASBs using software. Choose fire engineered sections if additional fire protection is to be avoided. Ensure that the depth of slab covers the ASB by at least 30 mm, or choose a slab depth to be level with the top of ASB, and provide reinforcing bars through the beam web.
4. Design edge beams using RHS Slimflor beams or downstand beams, where cladding details permit. Ensure the edge beam depth is compatible with the slab depth.

**Typical section sizes**

*Table 4.1 Typical sizes of ASB beams*

Beam span	Slab span		
	6	7.5*	9*
6 m	280 ASB100	280 ASB136	300 ASB153
7.5 m	280 ASB136	300 ASB153	300 ASB185
9 m	300 ASB153	300 ASB185	300 ASB249

\*decking requires propping

**Grade of steel**

ASBs are only available in S355 steel. RHS *Slimflor* beams are available in S275 and S355 steel.

**Overall floor zone**

1000 - 1200 mm with air conditioning (and raised floor) - see Figure 4.11  
 700 - 900 mm with light services (with raised floor) - see Figure 4.12

**Fire protection**

Fire engineered ASBs with the web and top flange encased in concrete do require additional fire protection for up to 60 minutes fire resistance. Thin web ASBs require fire protection for greater than 30 minutes fire resistance - normally by board to the bottom flange. RHS *Slimflor* edge beams normally require fire protection for greater than 60 minutes, usually by board protection to the exposed faces.

**Connections**

ASBs require end plate connections (typically, 6 or 8 bolt) to resist torsional loads. RHS *Slimflor* beams often use extended end plate connections to minimise the connection width.

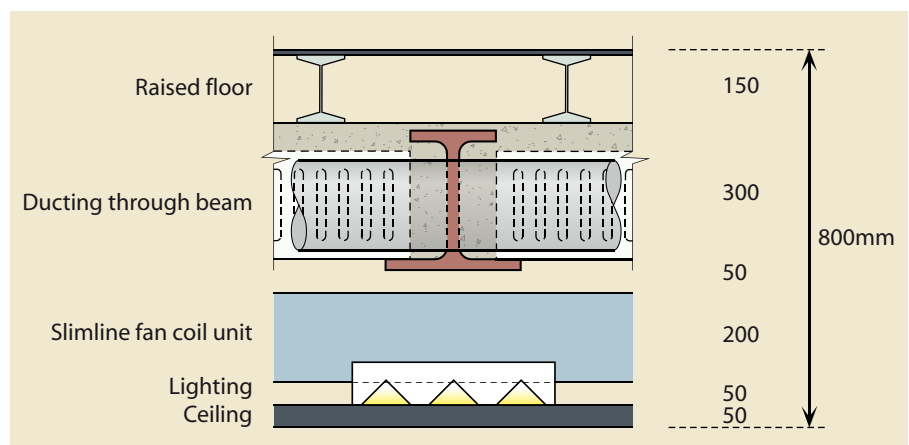

*Figure 4.12 Slimdek - typical cross-section showing services placed within the floor depth*

# 05 Beam Connections

All the floor systems reviewed in the previous sections utilise simple connections, which are not assumed to develop significant moments. However, some connections are also designed to resist torsional effects.

Full depth connections are provided for floor members that are subject to torsion, such as asymmetric beams for integrated floor systems.

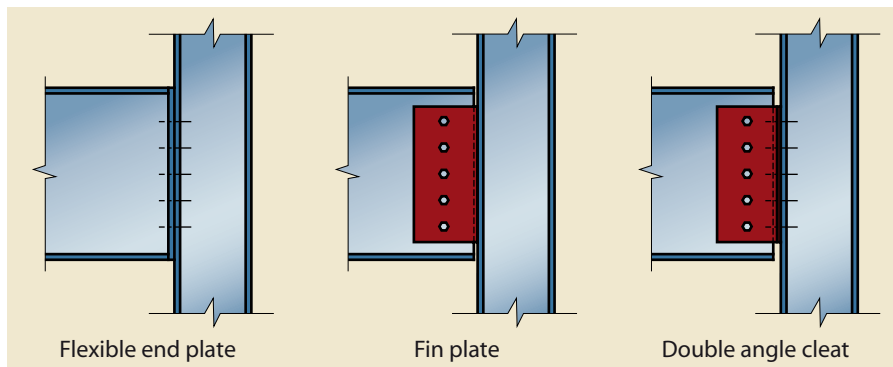

Figure 5.1 Standard simple beam connections

## Simple connections

Overall stability of the structure is normally provided by steel bracing or by a concrete core, in which case the connections between the steel members are not required to transfer high bending moments.

Provided connections are not subject to torsion, simple (vertical shear only) connections are usually detailed.

Standard connections are used, and the choice of detail is left to the steelwork contractor. The standard connections are the flexible end plate, a fin plate or double angle cleats, shown in Figure 5.1.

In general, end plates are used for beam to column connections. These end plates are sufficiently thin so that they do not attract large moments and are known as 'flexible' end plates. Connections to square hollow section columns are also

straight-forward, using flexible end plate and double angle cleat connections and proprietary 'blind' fixings, or bolts using formed, threaded holes.

Beam to beam connections also utilise standard details, although the secondary beam will need to be notched, as shown by a flexible end plate in Figure 5.2.

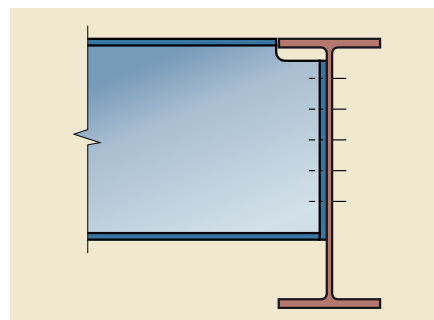

Figure 5.2 Beam to beam connection, showing need for a notched secondary beam

*Simple connections*

*Full depth end plates*

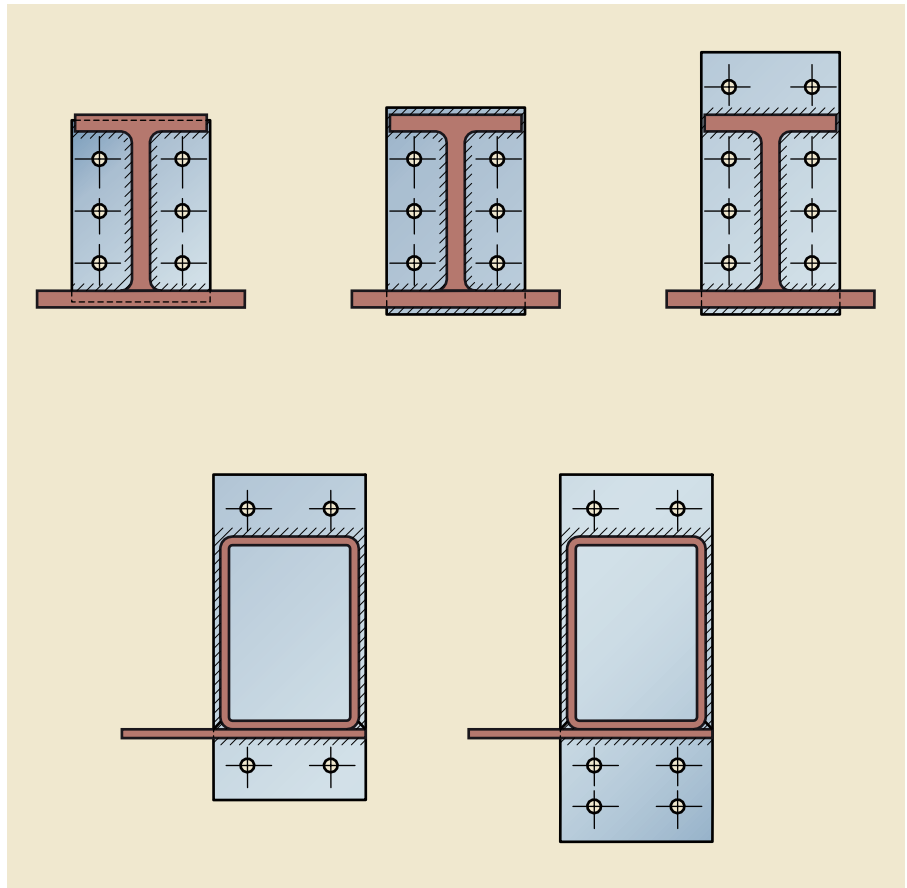

Figure 5.3 Full depth end plates for Integrated floor and edge beams

### Full depth end plates

When connections are subject to torsion, or are required to resist moments, the connection is usually fabricated with a full depth end plate, as shown in Figure 5.3. In these connections, the end plate is welded around the full profile of the member.

It is usual practice for the steelwork contractor to design the connections and the designer should provide connection forces and moments for the relevant stages, i.e. during construction and in the final state. This is because for many members such as integrated

beams, torsion may occur at the construction stage, when loads are only applied to one side of the member. Other members, such as edge beams, will be subject to torsion at all stages. In this case, both the welds and the bolt group must be checked for the combined effects of the applied torsion and vertical shear.

In addition to their bending resistance, these types of connections add to the stiffness of the beams and reduce deflections. This may be preferred in long-span applications.

# 06 Case Studies

A series of Case Studies are presented in this Section to illustrate the design and construction principles presented earlier. The Case Studies cover a range of building forms and locations throughout Europe.

The Case Studies and their structural systems are summarised as follows:

- *Mjärvedi Centre, Sweden*  
Integrated steel beams and concrete filled tubular columns.
- *ING Bank Headquarters, Amsterdam*  
*Slimdek* construction supported on inclined columns.
- *Chamber of Commerce, Luxembourg*  
Exposed stainless steel decking used as a composite slab and supported by long-span integrated beams.
- *HighLight Towers, Munich*  
Composite structure supported by concrete-filled tubular columns.
- *Palestra, London*  
Long-span fabricated beams arranged in pairs and supported by tubular columns.
- *Renovation of Alhóndiga, Bilbao*  
Renovation of an existing building by retaining the façade and using long-span trusses to create exhibition space.

*Mjärvedi Center,  
Sweden*

*ING Bank Headquarters,  
Amsterdam*

*Chamber of Commerce,  
Luxembourg*

*HighLight Towers,  
Munich*

*Palestra,  
London*

*Renovation of Alhóndiga,  
Bilbao*



## The Mjärdevi Center, Sweden

*Mjärdevi Center is an example of how traditional building techniques with pre-fabricated steel framing can be used in inspiring ways to create new ideas for the building industry.*

### Application Benefits:

- Columns filled with reinforced concrete are fire resistant and can be left exposed
- The shallow steel floor system is exposed through a leaning, curved glass façade
- Light steel sections support the glazed façade
- Prize winning architecture



Mjärdevi Science Park's vision is that it should be the *"right environment for the establishment and growth of developing and knowledge-intensive companies."* Mjärdevi Center is the centre and symbol of the Science Park and thus the building should, with boldness, express beliefs in the future.

The building consists of two distinct parts, one 12-storey part and a lower part forming a foundation to the higher building. The higher part of the building expands by leaning façades divided into two half

circles. The architect used classical geometrical figures. A slim, curved form was desired, like a vase or a sculpture.

An exterior cladding material is zinc, where the dark colour forms an outer framing for the transparent building. The building is given a sharp silhouette as a contrast to the flat surrounding countryside. In the higher part, the vertical structure is exposed with columns indented into the room. In the lower part, the steel structure is fully exposed and thus the exterior of the building reflects the interior.

**Project Team**

Client:

**Sankt Kors Fastighets AB**

Architect:

**Lund & Valentin arkitekter**

Project Manager:

**Hifab Byggprojektledaren AB**

Contractor, Framing:

**Strångbetong**

Contractor, Steel:

**PPTH-Norden Oy**

Structural Engineer:

**CSE projekt AB,****PPTH Engineering****Construction Details**

Steel columns (circular hollow sections) are used in combination with steel beams and hollowcore concrete slabs.

The steel columns (typically 200 mm diameter) are continuous over three storeys and were filled with reinforced concrete for composite action and fire resistance. This solution was chosen as the architect wanted the surface of the steel to be exposed. All steel columns are exposed except for the leaning columns in the façades on the gables.

The beams used are HEA-profiles in the façade (typically 240 mm) and omega-shaped profiles in the interior of the building. The leaning columns use VKR rectangular hollow sections, which are welded together and installed as a giant ladder. The horizontal beams hold these columns in place horizontally.

The floor consists of 270 mm deep hollowcore concrete units. Their span varies between 4 and 11 m, dependant on the building geometry.

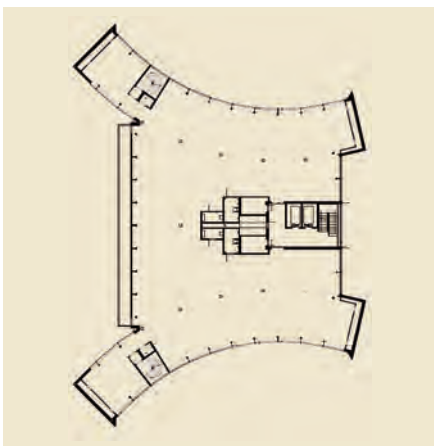

*Layout of the building, Floor 7*



*Mjärdevi Center under construction. Main framing and light steel for the exterior walls*  
Photo courtesy of PPTH

The building is stabilised by three staircases in precast concrete with post-tensioned bars over half the building height. One of the staircases is centrally located in the building and the other two in the gables. The central staircase uses a light coloured concrete with exposed surfaces.

The exterior walls use light steel C profiles combined with glass façades. An important issue was the small tolerances of the pre-fabricated façade and glass elements.

The building is an excellent example of how a pre-fabricated construction technology can be used to create an advanced architectural expression. The shallow dimensions of the steel frame are experienced through a light, leaning and curved glass façade.

## ING Bank Headquarters, Amsterdam

*The design team for the prestigious ING Bank headquarters in the Zuiderhof area of Amsterdam chose Slimdek because of its shallow depth for minimum visual impact, speed of installation, and light weight.*

### Application Benefits:

- Speed of construction of the superstructure
- Minimum structural depth for visual impact
- Service integration opportunities
- Reduced self weight for the ground conditions
- Reduced craneage requirement
- Limited access to site mitigated against concrete construction



End view of the ING building.  
Photo courtesy of G. Fessy, Parijs



The prestigious ING Bank headquarters in Amsterdam is one of the most exciting examples of steel construction using *Slimdek*. The 9-storey structure is approximately 20,000 m<sup>2</sup> floor area and the whole building is supported on inclined composite steel columns. The 'nose' of the building is designed as an auditorium and cantilevers 26 m from the adjoining *Slimdek* structure.

The architects Meyer and van Schooten were keen to use *Slimdek* because of experience on other projects, and because it offered the shallowest structural depth, a common requirement for building in the Netherlands. The double skin glazed façade also required the least depth of floor for minimum visual impact.

The structural grid was approximately 7 m square, making it ideal for *Slimdek*, using ASB steel sections and deep composite decking to create a slab depth of approximately 300 mm. Long-span

steel trusses were designed to support the superstructure and to resist the high forces created by the inclined columns that provide stability to the whole building.

The building is situated near the busy A10 motorway and therefore acoustic insulation and control of vibrations were also important design considerations. The space beneath the building provides access to the building and to the parking below.

The architect adopted a sophisticated servicing strategy in which the double skin façade was used to control 'solar gain' and internal temperatures. Services were located below the slab, with small pipes and cross-overs passing between the ribs of the deep decking.

All projects in the Netherlands are affected by high ground water level, and so there was an advantage in minimising ground works by concentrating loads at the discrete column positions.

**Project Team**

Client:

**ING Bank**

Architects:

**Meyer & Van Schooten,  
Ellerman,  
Lucas,  
Van Vugt Architects**

Structural Engineer:

**Aronsohn**

Steel Construction:

**HGO Group**

Decking:

**Dutch Engineering****Construction Details**

The structure consists of inclined columns of 10 m height which support the superstructure, varying in height from 4 to 9 storeys. The 280 ASB 136 beams span 7 m in four approximately equal bays across the building.

The superstructure spans between the inclined columns supported by a storey-high truss, which also resists the horizontal forces from the columns. The columns comprise I sections in a cruciform shape, with concrete infills for composite action and for resistance to impact.

The upper floors used deep decking spanning between the bottom flange of the ASB beams. Double lines of temporary props were used to control deflections on the 7.2 m deck span. The overall slab depth was 310 mm, the minimum sensible depth to meet deflection and vibration criteria. The ground floor used precast concrete slabs over the open access and car park area.

The lightweight façade and glazing was attached to the perimeter steelwork and provided a controlled internal environment, minimising on services installations. *Slimdek* also minimised the visual impact of the structure, which was important for the architectural concept.

The auditorium was conceived as a cantilever structure of 26 m span and 3 storeys height, which was supported by inclined members at each floor. Shallower CF100 decking was used in this cantilevered area, leading to 3.6 m unpropped spans (as propping was not practical in this area). Steelwork was supplied by a consortium of three steel fabricators, with ASB beams and decking supplied by Dutch Engineering.

Installation of the 1,000 tonnes of steelwork took only 28 weeks, despite the complex structure and site conditions. The congested site meant that the number of vehicles and deliveries had to be minimised. The choice of a lighter weight structure also reduced the amount of costly ground works.



Composite slab used in the auditorium area

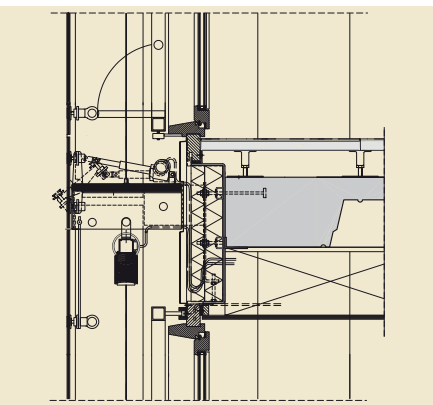

Floor detail.  
Photo courtesy of Meyer &  
Van Schooten, Amsterdam



## Chamber of Commerce, Luxembourg

*The new headquarters of the Chamber of Commerce in Luxembourg expresses the use of steel in its architecture and achieves energy savings through a water cooled stainless steel-faced sinusoidal composite slab.*

### Application Benefits:

- Long-span integrated beam system (12 m span)
- Exposed visually attractive sinusoidal deck profile
- Highly glazed façade
- Fire engineered design
- Energy efficient design using water cooling



The new headquarters of the chamber of commerce of the Grand Duchy of Luxembourg located on the Kirchberg plateau, comprises an existing building of 5,000 m<sup>2</sup> which is totally restored and 20,000 m<sup>2</sup> of new office space. A conference centre of approximately 8,000 m<sup>2</sup> completes this building together with 650 underground parking spaces on four levels. The total building area is 52,000 m<sup>2</sup> including car parking. It cost €70.4 million and was completed in 2003.

The new buildings form a succession of four distinct wings linked together by glass footbridges as well as another building along the adjacent street. This ensemble of buildings provides flexibility in office layout. The superstructures are completely detached from the ground floor and the buildings are glazed in serigraphed sun glass shields. The floors are made of pre-fabricated profiled panels in stainless steel which provide a waved interior facia of the ceiling.

The four and five-storey composite structure consists of hot rolled steel

sections and concrete floor slabs with integrated IFB-sections and under-tied main beams. These under-tied beams have a span of 12.5 m, which is much longer than conventional application of IFB beams.

The sinusoidal shaped stainless steel floor panels have a depth of 180 mm and act compositely with the in-situ concrete slab. They are supported on the bottom plate of the integrated steel beams. Plastic pipes are placed in the slab and provide for heating and cooling in the winter and summer. Heat gain is also reduced by solar shading to the glass façade. The glass elevators contribute to the lightness of these new headquarters. The internal walls in the office space use modular steel and glass partitions.

The diaphragm action of the floor slabs and vertical concrete stair and lift shafts provide the horizontal stability of the building. Building C is braced at one side with steel K-bracings.



**Project Team**

Architect:

**Vasconi Architects**

Structural Engineers:

**Schroeder, N Green, A Hunt**

Service Engineers:

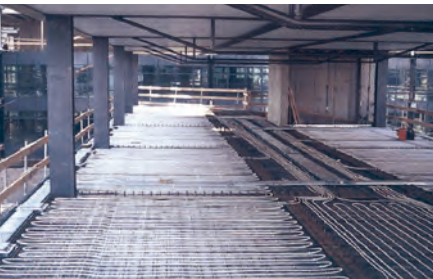
**RMC Consulting**

*Water heating/cooling pipework placed within the floor slab*

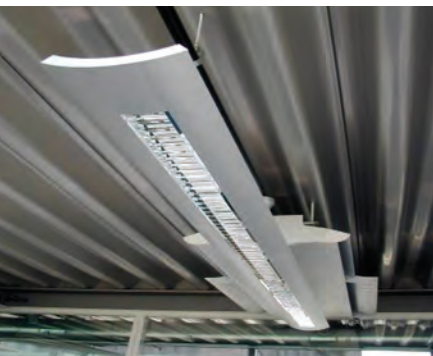

*Stainless steel profiled decking and lighting/air distribution units*

**Construction Details**

The steel beams span up to 12.5 m and are stiffened by the use of tubular ties below the integrated beams, which increase their span capabilities by 30%. The ties are visually unobtrusive and are exposed below the floor. Services are passed below the beams and above the ties to minimise the floor depth.

The sinusoidal stainless steel decking spans in the same direction as the main beams and is supported by the secondary beams at 4 m spacing. The decking supports the weight of concrete and propping is not required during construction.

The fire resistance of the integrated beams and steel columns were assessed by a fire engineering analysis, which demonstrated that 60 minutes fire resistance could be achieved without additional fire protection. The IFB beams are partially protected by the concrete slab and support the reduced design load in the fire despite the loss of the exposed ties.

For the energy efficiency strategy, the operating conditions of the water cooled slab is in 3 cycles, as follows:

**Summer - night time**

In the summer, cool water is passed during the night through plastic pipes embedded in the slab. The water circuit is reversed from 28/33°C to 14/18°C at 8 p.m.

**Summer - daytime**

If the night time cooling of the floor slab does not reach the parameters fixed previously in the morning (e.g. a maximum temperature of 21°C), the cooling circuit keeps functioning and the water is cooled by the circuit of the absorption chiller (at a temperature of 9/18°C).

The balance of the heating and the cooling is achieved by chilled beams in the ceiling fed by the heating and cooling networks. The pre-treated air is blown through an exchanger and mixed by a 'venturi' effect with the existing air.

**Winter**

The floor slab is heated in the winter months by passing hot water through the pipes in the floor slab. Heating of the supply water is supplemented by a heat exchanger using solar collectors.

## HighLight Towers, Munich

*In the north of Munich, a new ensemble of high-quality office buildings has been developed using innovative steel structures to maximise transparency and flexibility.*

### Application Benefits:

- Maximum internal flexibility due to absence of concrete walls and cores
- Innovative bracing system using steel space trusses
- Maximum transparency of façades
- Pre-fabricated façade panels
- High-quality working environments



HighLight Towers is a high-rise ensemble in the north of Munich, in Parkstadt Schwabing, a new residential and commercial district. The location is important, both within the immediate area, and for the city as a whole, as the towers overlook the junction of the main autobahn route from the north with the principal ring road around the inner city.

The objective of the concept design was to offer maximum transparency and flexibility with a minimum use of materials. All areas are flexible in use, high comfort, naturally ventilated and provide a pleasant working atmosphere. The slenderness of appearance and the transparency are the result of an innovative design and engineering concept, which could only be realised in steel and composite construction.

The high-rise towers have no bracing or concrete cores and no load-bearing inner walls; all partitions are lightweight

walls or glass walls; as are the walls of the staircases.

The ensemble consists of four buildings: HighLight Tower 1 and HighLight Tower 2 (33 and 28 storeys), flanked by a low-rise hotel block (7 storeys), and a HighLight Forum (5 floors), the latter two achieving a smooth transition to the surrounding commercial development.

The slender high-rise buildings have the form of rhomboids with a length of approximately 80 m and a depth of 13.5 m each.

The overall floor space is about 68,000 m<sup>2</sup>, comprising 61 lettable storeys with more than 1,000 m<sup>2</sup> each. The storey height of the ground level is 7.5 m, and of all upper storeys is 3.5 m.

The connecting bridges and glazed elevator shafts have no structural function, but play a key role in the visual image of this ensemble.

**Project Team**

Client:

**KanAm-Gruppe, München****Aareal Bank AG, Wiesbaden**

Architects:

**Murphy/Jahn Inc. Architects**

Structural Engineer:

**Werner Sobek****Ing. GmbH & Co. KG**

Steel Construction:

**Stahl + Verbundbau GmbH**

General Contractor:

**Strabag AG**

Façades:

**Schmidlin AG****Construction Details****Support structure**

The main structure of the two towers is an innovative composite construction of steel and concrete. Its principal elements are concrete-filled tubular steel columns with a core of solid steel and flat slabs of reinforced concrete with upstand beams around the perimeter. The towers are stabilised by two trussed steel frames at both ends of the buildings. These frames consist of three inter-connected trussed sections: a truss 12 m wide across the width of the building, plus sections 8 m and 6.75 m wide parallel to the long façades. On plan, the three sections form a U-shape.

Each bracing module spans two floors vertically, which means the columns and the diagonals pierce the intermediate floors lying between two main nodes in the frame.

The columns outside the trussed bracing are designed as composite columns, generally tubular sections with a steel core and filled with concrete. In both high-rise buildings, more than 1,100 single-storey composite columns are used, which are simply connected to each other as in a construction kit.

Generally, S355 steel grade is used. High-strength steel grades S460 and S690 are used in the connections,

*Impressions from the construction process of the steel framework bracings.*  
Photos courtesy of stahl+verbundbau GmbH, Dreieich



taking account of weldability and low residual stress.

The intermediate floors are reinforced concrete flat slabs that are 280 mm thick, with an integrated heating and cooling system. Each of the towers is covered with a space frame that is fully glazed. This steel and glass structure extends over two storeys, enclosing the top-most gallery level.

All four buildings of this ensemble are located over a three-storey underground car park.

All load-bearing and bracing elements with their supports are designed for 120 minutes fire resistance and others for 90 minutes.

**Façades**

Each tower is clad with a single-skin curtain wall made up of pre-fabricated storey-high façade panels using thermally insulated metal profiles. The individual panels are divided into two glazed sections with solar shading, 400 and 950 mm wide, in which the smaller one can be opened for natural ventilation.





## Palestra, London

*A new design concept on London's Blackfriars Road demonstrates a range of new steel construction technologies, including cement grout-filled columns, and continuous twin beams which achieve the minimum structural depth.*

### Application Benefits:

- Long-span but shallow construction
- Stiff floor due to continuity in the beams
- Inclined tubular columns
- Fire engineered solution
- Highly glazed façade
- Rapid construction programme



Architect Alsop's Palestra building uses many innovative design concepts to create this 28,000 m<sup>2</sup> commercial development in Southwark, London. The 12 storey composite structure comprises tubular columns that support pairs of continuous cellular beams connected by brackets to the columns.

At the 9th floor, the building projects outwards by up to 9 m on the front elevation and 1.5 m on the side elevations. On the ground and 7th floor, columns are inclined to add to the visual interest, which was accommodated by the unusual structural system chosen by structural engineer, Buro Happold.

The building is 31.5 to 36 m wide and approximately 90 m long and has three service and lift cores. The floor to floor depth is only 3.65 m. The 3,500 tonnes of steelwork was installed in only 32 weeks, and the structure was completed in 10 months out of a 30 month overall construction programme.

Servicing is by fan coil units placed between the beams. Ducts and pipes pass in a 400 mm deep zone below the secondary beam and through the regular circular openings in the primary beams, which provide for future upgrading of the services.

Cement-filled tubular columns incorporate an internal CHS, used instead of concrete-filled steel tubes with reinforcement. In this way, the compressive resistance is improved and the fire resistance of the 508 mm diameter circular columns can achieve 120 minutes without an application of secondary fire protection such as intumescent coating or boarding. The columns were cement-filled over 9 floors from the top in one go. This increased the speed of installation and simplified the construction programme. Holes at the top and bottom of the columns at each storey height provide for venting of steam inside the column in the event of fire.

The façade is fully glazed by storey-high panels from supplier, Permasteelisa. The principle is based on a structural silicone-glazed system.



**Project Team**

Client:

**Blackfriars Investments and  
Royal London Asset Management  
joint venture**

Architect:

**Alsop and Partners**

Structural Engineer:

**Buro Happold**

Contractor:

**Skanska**

Steel Contractor:

**William Hare**

Steel Decking:

**Richard Lees Steel Decking Ltd****Construction Details**

The twin fabricated cellular beams are 600 mm deep within an overall combined structural services zone of 900 mm.

The beams typically comprise 25 mm thick flange plates and 15 mm web, which are designed to transfer shear across the 400 mm diameter openings without requiring stiffeners. Continuity in the primary beams improves the enhanced stiffness and vibration characteristics of the floor structure, with the pinned splice located at the point of contraflexure.

The 200 mm deep secondary beams are designed compositely and span 6.65 m, between the twin primary beams. These beams are connected to the web of the primary beams so that the top of the 140 mm deep composite slab is level with the top of the primary beams.

A fire resistance of 90 minutes is achieved by applying only a thin single layer of intumescent coating to the fabricated beams. The primary beams

are also designed to act compositely with the slab. Instead of using conventional shear connectors, composite action is achieved by passing reinforcement through holes in the web into the slab.

The columns are inclined on two floors, and this feature, combined with the significant overhang at the 9th floor, creates permanent horizontal forces on the building, the magnitude of which are in the region of 20 times the force experienced by the building due to winds. The steel and concrete frame transfers the high forces back to the steel K braced stability system.

The composite slab uses *Ribdek* 60 or *Ribdek* 80 profiles, depending on the span. Special details were required at the primary beams where the deck was not directly supported by the beam flange. This required welding plates at intervals to the beam web and fixing light steel angles to the plates to prevent local deformation and concrete loss.



Pairs of cellular beams



Tubular column connection



## Renovation of Alhóndiga, Bilbao

Bilbao's old municipal wine storage facility (Alhóndiga) is a city-centre historical building undergoing renovation to produce a multi-disciplinary space. **Alhóndiga** Bilbao will hold the new Culture and Leisure Centre with a floor area of more than 40,000 m<sup>2</sup>, divided into four different areas with a steel structure weighing more than 4000 tonnes.

### Application Benefits:

- Economy and quality arising from use of off-site manufacture
- Maximum flexibility to accommodate architectural solutions
- Fast construction programme
- Long-span floors, offering optimum use of the space
- Slender columns, giving the impression of openness
- Economy in meeting fire resistance requirements



Top view of the construction site (May 2006)



The *Alhóndiga*, a famous civic wine store in Bilbao, was designed by architect Ricardo Bastida, and the brick and reinforced concrete building was completed in 1909. After 1970, the *Alhóndiga* fell into disuse and in 1998, a decision was made to renovate it. The renovation project **Alhóndiga** Bilbao has been divided into a number of phases.

In 2001, the inner part of the original building was demolished above ground level followed by the strengthening of the perimeter old walls, basements and semi-basements, together with renovation work on the façade and the towers. The construction of an underground car park with a capacity of 985 parking spaces (5800 m<sup>2</sup> per floor) in 5 storeys began in 2002 and was completed in November 2004.

The last phase in the project began in December 2005 and consisted of the construction of three mixed-use buildings of 7 storeys (2 semi-basements, ground floor and 4 upper storeys) and a large open atrium at ground floor level.



(Above) Perimeter cantilever of the atrium lattice girders

(Top) Alhóndiga in construction

**Alhóndiga** Bilbao will hold a new culture and leisure centre which will create a multi purpose space for activities related to knowledge, health and entertainment. The building is intended to become a reference for development and extension of city culture, modernity, new trends and healthy living. The total budget of the project is around 65 million Euros. The renovated building was designed by the French industrial designer, Philippe Starck, and its total area is more than 40,000 m<sup>2</sup>.

Internally, approximately 4000 tonnes of steel and 14,000 m<sup>2</sup> of pre-stressed concrete hollow core slabs have been installed.

**Project Team**

Client:

**Bilbao Town Hall (La Alhóndiga, Centro de Ocio y Cultura, S.A.U.)**

Site management:

**BILBAO Ría 2000**

Architecture and design:

**Philippe Starck- Starck Networks**

Technical Assistance

and Site Management:

**Temporary Company Merger****MECSA-ARUP**

Structures:

**Temporary Company Merger****for Structures Alhóndiga****(URSA S.Coop, DRAGADOS S.A.,****FONORTE Empresa****Constructora, S.A.)****Construction Time**

Initiation:

**December 2005**

Inauguration:

**Around the middle of 2009**

*Bolted connection in a column placed in a corner between two cubes*

**Construction Details**

The atrium, 6195 m<sup>2</sup> in area, is the main feature; it provides the entrance hall and leads to the semi-basements and the three 'cube' buildings. The cubes house most of the activities, grouped by themes: *knowledge, health* and *entertainment* including auditorium, cinemas, swimming pool, gym, school of Scene & Dance Arts, and small business premises.



*Steel structure of the main entrance hall in front of the cubes*

**Structure**

The atrium structure is made from cruciform columns fabricated from HEA 550 sections (steel grade S355JR) of 16 m length. The ceiling of the atrium consists of lattice girders (HEA 220 and HEB 140 in the chords) of 8 m span and 0.9 m depth. A perimeter cantilever of 9 m span and 1.5 m depth has been created.

The three cube-shaped buildings have similar steel frames: columns made of circular hollow sections of 700 mm diameter and 3 m height between floors, with bolted connections to the steel

beams. The section of the beams used in the cubes changes based on the functional use of the building. One of the cubes is made up of double lattice girders of 0.9 m deep and 17 m span; and the cube used for sports has plated girders of 1.6 m depth and 35 m span.

The connections of the steel frame were bolted on site, a method chosen for speed of construction and independence from the weather conditions.

**Fire safety concept**

For the fire structural design, the Spanish standard CTE DB-SI was applied. Part of the steel structure is exposed and therefore a special fire protection system was needed. This fire protection system uses intumescent coating to provide a fire resistance of 60 minutes for the primary structure.

The initial fire resistance requirement according to CTE DB-SI was for 120 minutes fire resistance, but that requirement was reduced to 60 minutes by adopting a Fire Safety Engineering (FSE) approach. Using FSE, it was possible to carry out several analyses to demonstrate the safety levels of the **Alhóndiga** Bilbao by specific studies on:

- Smoke ventilation in the atrium.
- Fire resistance analysis of the complete structure.
- Advanced fire simulations including fire scenarios.

**ArcelorMittal**

Long Carbon, Research and Development,  
66, rue de Luxembourg, L - 4009 Esch/Alzette, Luxembourg  
[www.arcelormittal.com](http://www.arcelormittal.com)

**Bouwen met Staal**

Boerhaavelaan 40, NL - 2713 HX Zoetermeer,  
Postbus 190, NL - 2700 AD Zoetermeer, The Netherlands  
[www.bouwenmetstaal.nl](http://www.bouwenmetstaal.nl)

**Centre Technique Industriel de la Construction Métallique (CTICM)**

Espace Technologique, L'orme des merisiers - Immeuble Apollo,  
F - 91193 Saint-Aubin, France  
[www.cticm.com](http://www.cticm.com)

**Forschungsvereinigung Stahlanwendung (FOSTA)**

Sohnstraße 65, D - 40237 Düsseldorf,  
Germany  
[www.stahlforschung.de](http://www.stahlforschung.de)

**Labein - Tecnalia**

C/Geldo - Parque Tecnológico de Bizkaia - Edificio 700,  
48160 Derio, Bizkaia, Spain  
[www.labein.es](http://www.labein.es)

**SBI**

Vasagatan 52, SE - 111 20 Stockholm,  
Sweden  
[www.sbi.se](http://www.sbi.se)

**The Steel Construction Institute (SCI)**

Silwood Park, Ascot, Berkshire,  
SL5 7QN, United Kingdom  
[www.steel-sci.org](http://www.steel-sci.org)

**Technische Universität Dortmund**

Fakultät Bauwesen - Lehrstuhl für Stahlbau  
August-Schmidt-Strasse 6, D - 44227 Dortmund, Germany  
[www.uni-dortmund.de](http://www.uni-dortmund.de)