

STEEL BUILDINGS IN EUROPE

Single-Storey Steel Buildings

Part 4: Detailed Design of Portal Frames

FOREWORD

This publication is part four of the design guide, *Single-Storey Steel Buildings*.

The 11 parts in the *Single-Storey Steel Buildings* guide are:

- Part 1: Architect's guide
- Part 2: Concept design
- Part 3: Actions
- Part 4: Detailed design of portal frames
- Part 5: Detailed design of trusses
- Part 6: Detailed design of built up columns
- Part 7: Fire engineering
- Part 8: Building envelope
- Part 9: Introduction to computer software
- Part 10: Model construction specification
- Part 11: Moment connections

Single-Storey Steel Buildings is one of two design guides. The second design guide is *Multi-Storey Steel Buildings*.

The two design guides have been produced in the framework of the European project "Facilitating the market development for sections in industrial halls and low rise buildings (SECHALO) RFS2-CT-2008-0030".

The design guides have been prepared under the direction of Arcelor Mittal, Peiner Träger and Corus. The technical content has been prepared by CTICM and SCI, collaborating as the Steel Alliance.

Contents

	Page No
FOREWORD	iii
SUMMARY	vii
1 INTRODUCTION	1
1.1 Scope	1
1.2 Computer-aided design	1
2 SECOND ORDER EFFECTS IN PORTAL FRAMES	3
2.1 Frame behaviour	3
2.2 Second order effects	4
2.3 Design summary	5
3 ULTIMATE LIMIT STATE	6
3.1 General	6
3.2 Imperfections	8
3.3 First order and second order analysis	13
3.4 Base stiffness	16
3.5 Design summary	18
4 SERVICEABILITY LIMIT STATE	20
4.1 General	20
4.2 Selection of deflection criteria	20
4.3 Analysis	20
4.4 Design summary	20
5 CROSS-SECTION RESISTANCE	21
5.1 General	21
5.2 Classification of cross-section	21
5.3 Member ductility for plastic design	21
5.4 Design summary	22
6 MEMBER STABILITY	23
6.1 Introduction	23
6.2 Buckling resistance in EN 1993-1-1	24
6.3 Out-of-plane restraint	26
6.4 Stable lengths adjacent to plastic hinges	28
6.5 Design summary	31
7 RAFTER DESIGN	32
7.1 Introduction	32
7.2 Rafter strength	32
7.3 Rafter out-of-plane stability	33
7.4 In-plane stability	37
7.5 Design summary	37
8 COLUMN DESIGN	38
8.1 Introduction	38
8.2 Web resistance	38
8.3 Column stability	38
8.4 In-plane stability	41
8.5 Design summary	41
9 BRACING	42
9.1 General	42

Part 4: Detailed Design of Portal Frames

9.2	Vertical bracing	42
9.3	Plan bracing	48
9.4	Restraint to inner flanges	50
9.5	Bracing at plastic hinges	51
9.6	Design summary	52
10	GABLES	53
10.1	Types of gable frame	53
10.2	Gable columns	53
10.3	Gable rafters	54
11	CONNECTIONS	55
11.1	Eaves connections	55
11.2	Apex connections	56
11.3	Bases, base plates and foundations	57
11.4	Design summary	62
12	SECONDARY STRUCTURAL COMPONENTS	63
12.1	Eaves beam	63
12.2	Eaves strut	63
13	DESIGN OF MULTI-BAY PORTAL FRAMES	64
13.1	General	64
13.2	Types of multi-bay portals	64
13.3	Stability	65
13.4	Snap through instability	66
13.5	Design summary	66
	REFERENCES	67
Appendix A	Practical deflection limits for single-storey buildings	69
A.1	Horizontal deflections for portal frames	69
A.2	Vertical deflections for portal frames	71
Appendix B	Calculation of $\alpha_{cr,est}$	73
B.1	General	73
B.2	Factor $\alpha_{cr,s,est}$	73
Appendix C	Determination of M_{cr} and N_{cr}	76
C.1	M_{cr} for uniform members	76
C.2	M_{cr} for members with discrete restraints to the tension flange	77
C.3	N_{cr} for uniform members with discrete restraints to the tension flange	79
Appendix D	Worked Example: Design of portal frame using elastic analysis	81

SUMMARY

This publication provides guidance on the detailed design of portal frames to the Eurocodes.

An introductory section reviews the advantages of portal frame construction and clarifies that the scope of this publication is limited to portal frames without ties between eaves. Most of the guidance is related to single span frames, with limited guidance for multi-span frames.

The publication provides guidance on:

- The importance of second order effects in portal frames
- The use of elastic and plastic analysis
- Design at the Ultimate and Serviceability Limit States
- Element design: cross-section resistance and member stability
- Secondary structure: gable columns, bracing and eaves members.

The document includes a worked example, demonstrating the assessment of sensitivity to second order effects, and the verification of the primary members.

1 INTRODUCTION

Steel portal frames are very efficient and economical when used for single-storey buildings, provided that the design details are cost effective and the design parameters and assumptions are well chosen. In countries where this technology is highly developed, the steel portal frame is the dominant form of structure for single-storey industrial and commercial buildings. It has become the most common structural form in pitched roof buildings, because of its economy and versatility for a wide range of spans.

Where guidance is given in detail elsewhere, established publications are referred to, with a brief explanation and review of their contents. Cross-reference is made to the relevant clauses of EN 1993-1-1^[1].

1.1 Scope

This publication guides the designer through all the steps involved in the detailed design of portal frames to EN 1993-1-1, taking due account of the role of computer analysis with commercially available software. It is recognised that the most economic design will be achieved using bespoke software. Nevertheless this document provides guidance on the manual methods used for initial design and the approaches used in software. The importance of appropriate design details is emphasised, with good practice illustrated.

This publication does not address portal frames with ties between eaves. These forms of portal frame are relatively rare. The ties modify the distribution of bending moments substantially and increase the axial force in the rafter dramatically. Second order software must be used for the design of portal frames with ties at eaves level.

An introduction to single-storey structures, including portal frames, is given in a complementary publication *Single-storey steel buildings. Part 2: Concept design*^[2].

1.2 Computer-aided design

Although portal frames may be analysed by manual methods and members verified by manual methods, software is recommended for greatest structural efficiency. Bespoke software for portal frame design is widely available, which will:

- undertake elastic-plastic analysis
- allow for second order effects
- verify members
- verify connections.

Generally, a number of different load combinations will have to be considered during the design of a portal frame. Software that verifies the members for all load combinations will shorten the design process considerably.

Part 4: Detailed Design of Portal Frames

Whilst manual design may be useful for initial sizing of members and a thorough understanding of the design process is necessary, the use of bespoke software is recommended.

2 SECOND ORDER EFFECTS IN PORTAL FRAMES

2.1 Frame behaviour

The strength checks for any structure are valid only if the global analysis gives a good representation of the behaviour of the actual structure.

When any frame is loaded, it deflects and its shape under load is different from the un-deformed shape. The deflection causes the axial loads in the members to act along different lines from those assumed in the analysis, as shown diagrammatically in Figure 2.1 and Figure 2.2. If the deflections are small, the consequences are very small and a first-order analysis (neglecting the effect of the deflected shape) is sufficiently accurate. However, if the deflections are such that the effects of the axial load on the deflected shape are large enough to cause significant additional moments and further deflection, the frame is said to be sensitive to second order effects. These second order effects, or P-delta effects, can be sufficient to reduce the resistance of the frame.

These second order effects are geometrical effects and should not be confused with non-linear behaviour of materials.

As shown in Figure 2.1, there are two categories of second order effects:

Effects of deflections within the length of members, usually called $P-\delta$ (P-little delta) effects.

Effects of displacements of the intersections of members, usually called $P-\Delta$ (P-big delta) effects.

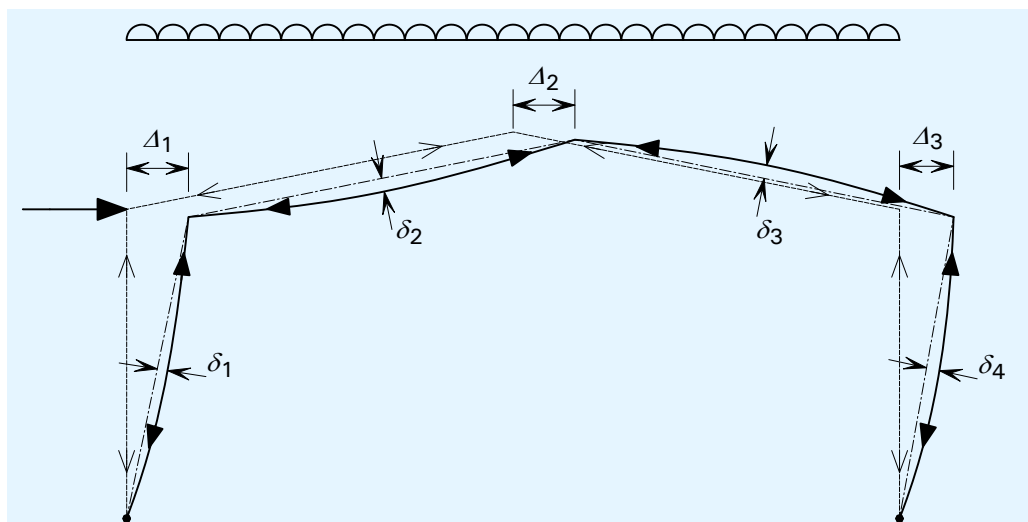

Figure 2.1 Asymmetric or sway mode deflection

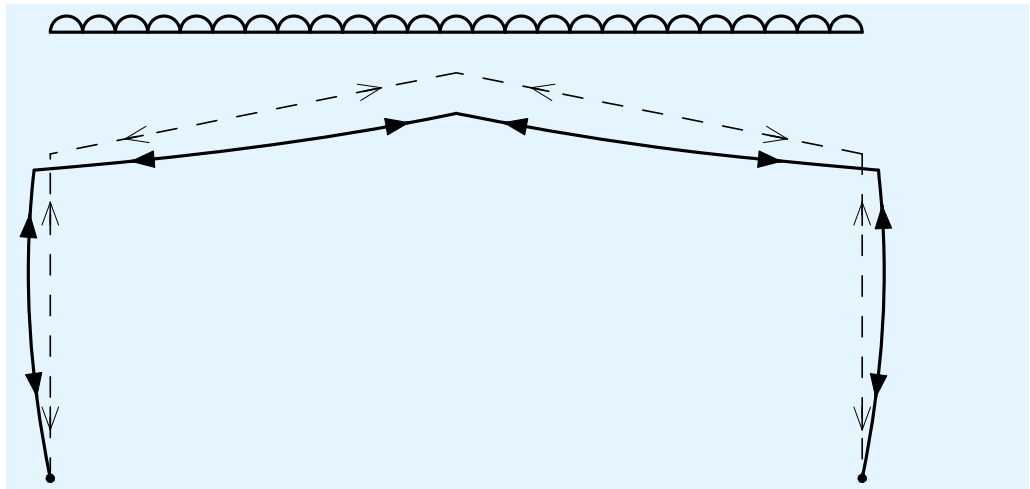

Figure 2.2 Symmetric mode deflection

The practical consequence of $P-\delta$ and $P-\Delta$ effects is to reduce the stiffness of the frames and its elements below that calculated by first-order analysis. Single-storey portals are sensitive to the effects of the axial compression forces in the rafters and columns. These axial forces are commonly of the order of 10% of the elastic critical buckling loads of the rafters and columns, around which level the reduction in effective stiffness becomes important.

2.2 Second order effects

Second order effects increase not only the deflections but also the moments and forces beyond those calculated by first-order analysis. Second order analysis is the term used to describe analysis methods in which the effects of increasing deflection under increasing load are considered explicitly in the solution, so that the results include the $P-\Delta$ and $P-\delta$ effects described in Section 2.1. The results will differ from the results of first-order analysis by an amount dependent on the magnitude of the $P-\Delta$ and $P-\delta$ effects.

The effects of the deformed geometry are assessed in EN 1993-1-1 by calculating the factor α_{cr} , defined as:

$$\alpha_{cr} = \frac{F_{cr}}{F_{Ed}}$$

where:

F_{cr} is the elastic critical load vector for global instability, based on initial elastic stiffnesses

F_{Ed} is the design load vector on the structure.

Second order effects can be ignored in a first order analysis when the frame is sufficiently stiff. According to § 5.2.1 (3), second order effects may be ignored when:

For elastic analysis: $\alpha_{cr} \geq 10$

For plastic analysis: $\alpha_{cr} \geq 15$

α_{cr} may be found using software or (within certain limits) using Expression 5.2 from EN 1993-1-1. When the frame falls outside the limits, an alternative expression may be used to calculate an approximate value of α_{cr} . Further details are given in Section 3.3.

When second order effects are significant, two options are possible:

- Rigorous 2nd order analysis (i.e. in practice, using an appropriate second order software)
- Approximate 2nd order analysis (i.e. hand calculations using first-order analysis with appropriate allowance for second order effects).

In the second method, also known as ‘modified first order analysis’, the applied actions are amplified, to allow for second order effects while using first order calculations. This method is described in Section 3.3.

2.3 Design summary

- Second order effects occur in the overall frame ($P-\Delta$) and within elements ($P-\delta$).
- Second order effects are quantified by the factor α_{cr} .
- For portal frames, the expression given to calculate α_{cr} in EN 1993-1-1 § 5.2.1(4) may be used within certain limits. Outside the limits prescribed by the Standard, an alternative calculation must be made, as described in Appendix B.
- Second order effects may be significant in practical portal frames.
- Second order effects may be accounted for by either rigorous second order analysis using software or by a first order analysis that is modified by an amplification factor on the actions.

3 ULTIMATE LIMIT STATE

3.1 General

Methods of frame analysis at the Ultimate Limit State fall broadly into two types – elastic analysis (see Section 3.2.2) and plastic analysis (see Section 3.2.3). The latter term covers both rigid-plastic and elastic-plastic analyses.

The formation of hinges and points of maximum moment and the associated redistribution of moment around the frame that are inherent to plastic analysis are key to the economy of most portal frames. They ‘relieve’ the highly stressed regions and allow the capacity of under-utilised parts of the frame to be mobilised more fully.

These plastic hinge rotations occur at sections where the bending moment reaches the plastic moment or resistance at load levels below the full ULS loading.

An idealised ‘plastic’ bending moment diagram for a symmetrical portal under symmetrical vertical loads is shown in Figure 3.1. This shows the position of the plastic hinges for the plastic collapse mechanism. The first hinge to form is normally adjacent to the haunch (shown in the column in this case). Later, depending on the proportions of the portal frame, hinges form just below the apex, at the point of maximum sagging moment.

A portal frame with pinned bases has a single degree of indeterminacy. Therefore, two hinges are required to create a mechanism. The four hinges shown in Figure 3.1 only arise because of symmetry. In practice, due to variations in material strength and section size, only one apex hinge and one eaves hinge will form to create the mechanism. As there is uncertainty as to which hinges will form in the real structure, a symmetrical arrangement is assumed, and hinge positions on each side of the frame restrained.

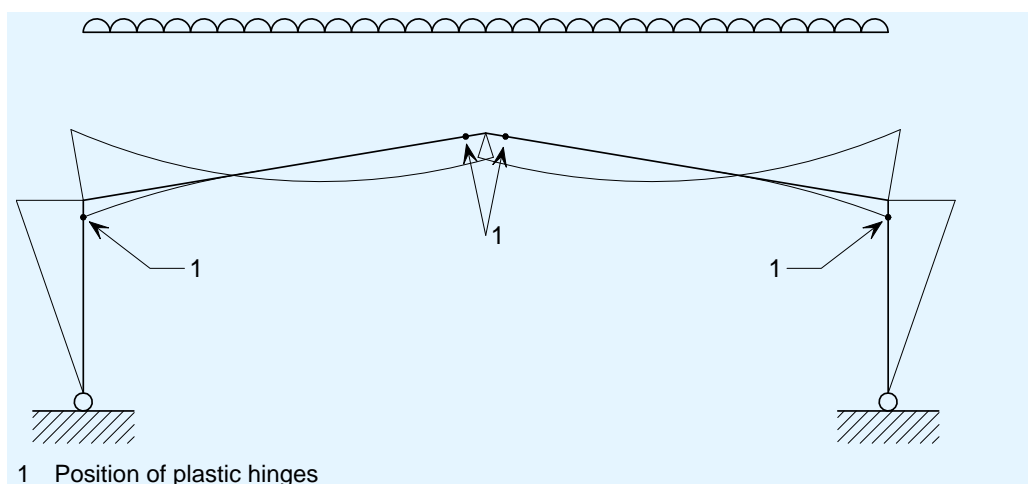

Figure 3.1 Bending moment diagram resulting from the plastic analysis of a symmetrical portal frame under symmetrical vertical loading

Most load combinations will be asymmetric because they include either equivalent horizontal forces (EHF; see Section 3.2) or wind loads. A typical loading diagram and bending moment diagram are shown in Figure 3.2. Both the wind and the EHF can act in either direction, meaning the hinge positions on each side of the frame must be restrained.

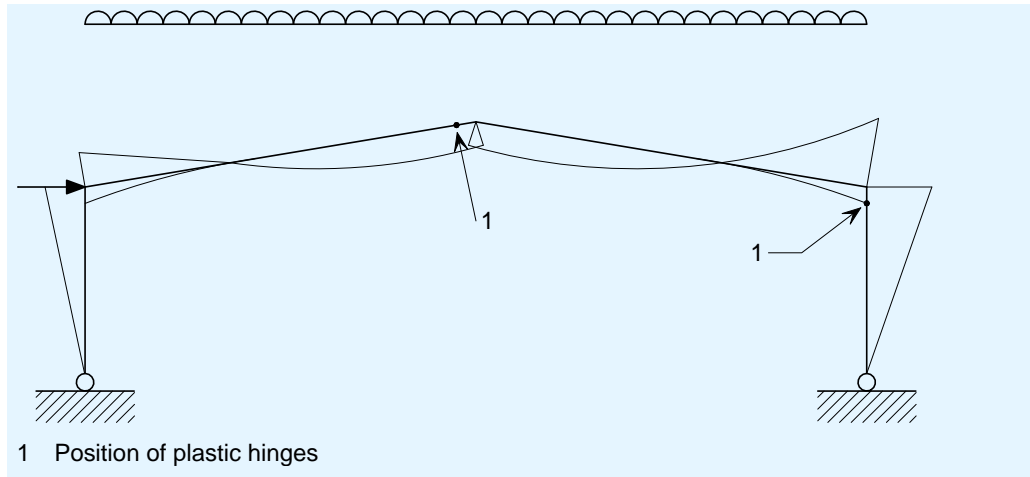

Figure 3.2 Bending moment diagram resulting from plastic analysis of a symmetrical portal frame under asymmetric loading

A typical bending moment diagram resulting from an elastic analysis of a frame with pinned bases is shown in Figure 3.3. In this case, the maximum moment (at the eaves) is higher than that calculated from a plastic analysis. Both the column and haunch have to be designed for these larger bending moments. The haunch may be lengthened to around 15% of the span, to accommodate the higher bending moment.

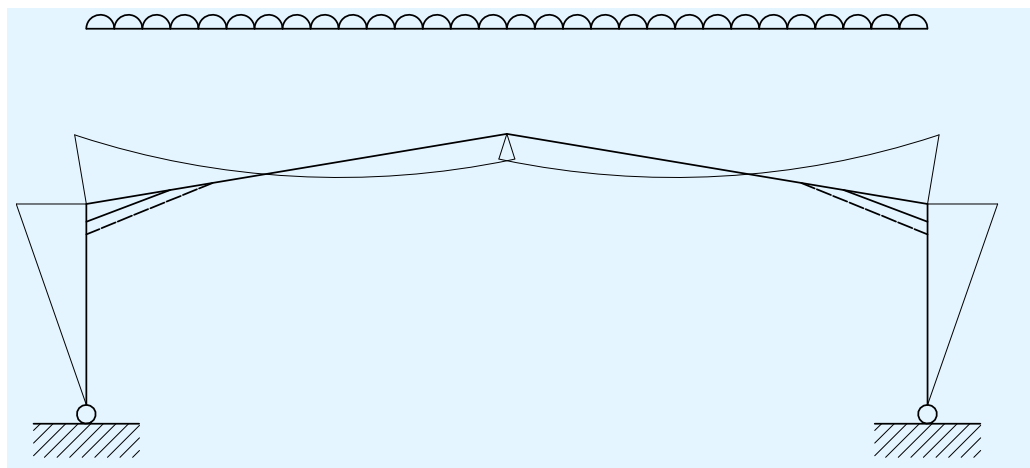

Figure 3.3 Bending moment diagram resulting from the elastic analysis of a symmetrical portal frame under symmetrical loading (haunch at 10% of span is denoted by solid line; that for 15% of span is denoted by a dotted line)

3.2 Imperfections

Frame imperfections are addressed in EN 1993-1-1 § 5.3.2. Generally, frame imperfections must be modelled. The frame may be modelled out-of-plumb, or alternatively, a system of equivalent horizontal forces (EHF) may be applied to the frame to allow for imperfections. The use of EHF is recommended as the simpler approach.

3.2.1 Equivalent horizontal forces

The use of equivalent horizontal forces (EHF) to allow for the effects of initial sway imperfections is allowed by § 5.3.2(7). The initial imperfections are given by Expression 5.5, where the initial imperfection ϕ (indicated as an inclination from the vertical) is given as:

$$\phi = \phi_0 \alpha_h \alpha_m$$

where:

ϕ_0 is the basic value: $\phi_0 = 1/200$

$$\alpha_h = \frac{2}{\sqrt{h}} \text{ but } \frac{2}{3} \leq \alpha_h \leq 1,0$$

h is the height of the structure in metres

$$\alpha_m = \sqrt{0,5 \left(1 + \frac{1}{m} \right)}$$

m is the number of columns in a row – for a portal the number of columns in a single frame.

For single span portal frames, h is the height of the column, and $m = 2$.

It is conservative to set $\alpha_h = \alpha_m = 1,0$.

EHF may be calculated as ϕ multiplied by the vertical reaction at the base of the column (including crane loads as appropriate). The EHF are applied horizontally, in the same direction, at the top of each column.

§ 5.3.2(4) states that sway imperfections may be disregarded when $H_{Ed} \geq 0,15 V_{Ed}$.

It is recommended that this relaxation is tested by comparing the net total horizontal reaction at the base with the net total vertical reaction. In many cases, the expression given in 5.3.2(4) will mean that EHF are not required in combinations of actions that include wind actions. However, EHF will need to be included in combinations of only gravity actions.

3.2.2 Elastic analysis

Elastic analysis is the most common method of analysis for general structures, but will usually give less economical portal structures than plastic analysis. EN 1993-1-1 allows the plastic cross-sectional resistance to be used with the results of elastic analysis, provided the section class is Class 1 or Class 2. In addition, it allows 15% of moment redistribution as defined in EN 1993-1-1 § 5.4.1.4(B)

Designers less familiar with steel design may be surprised by the use of plastic moment of resistance and redistribution of moment in combination with elastic analysis. However, it should be noted that, in practice:

- Because of residual stresses, member imperfections, real inertias that differ from those assumed, real connection stiffness that differs from that assumed and lack of fit at connections, the true distribution of moments in any frame is likely to differ substantially from that predicted by elastic analysis.
- Class 1 and 2 sections are capable of some plastic rotation before there is any significant reduction in capacity due to local buckling. This justifies a redistribution of 15% of moments from the nominal moments determined from the elastic analysis.

The results of elastic analysis should therefore be regarded as no more than a reasonably realistic system of internal forces that are in equilibrium with the applied loads.

In a haunched portal rafter, up to 15% of the bending moment at the sharp end of the haunch can be redistributed, if the bending moment exceeded the plastic resistance of the rafter and the moments and forces resulting from redistribution can be carried by the rest of the frame. Alternatively, if the moment at the midspan of the portal exceeded the plastic resistance of the rafter, this moment can be reduced by up to 15% by redistribution, provided that the remainder of the structure can carry the moments and forces resulting from the redistribution.

If an elastic analysis reveals that the bending moment at a particular location exceeds the plastic moment of resistance, the minimum moment at that point after redistribution should be the plastic moment of resistance. This is to recognise that a plastic hinge may form at that point. To allow reduction below the plastic resistance would be illogical and could result in dangerous assumptions in the calculation of member buckling resistance.

3.2.3 Plastic analysis

Plastic analysis is not used extensively in continental Europe, even though it is a well-proven method of analysis. However, plastic analysis is used for more than 90% of portal structures in the UK and has been in use for 40 years.

Traditionally, manual calculation methods were used for a plastic analysis (the so-called graphical method, or the virtual work method, etc.). These manual methods are not discussed in this publication, because plastic analysis is usually undertaken with software, most of the time using the elastic-perfectly-plastic method. The principle of this method is illustrated in Figure 3.4 and Figure 3.5.

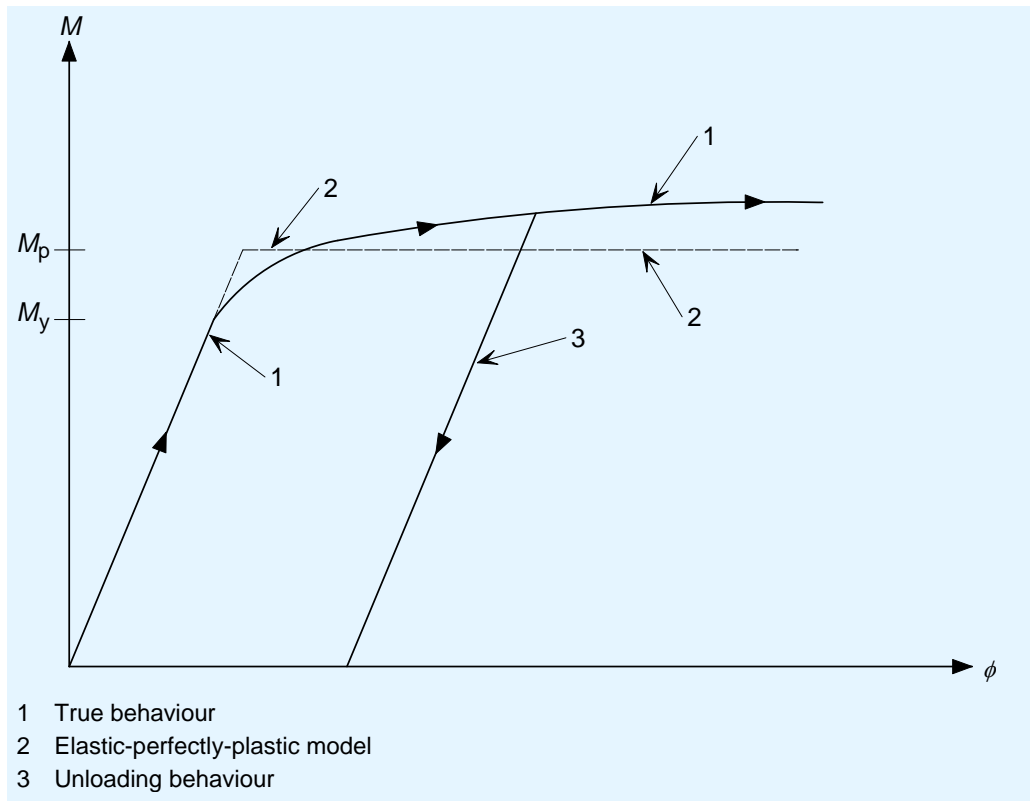

Figure 3.4 Moment/rotation behaviour and elastic-perfectly-plastic model for a Class 1 section

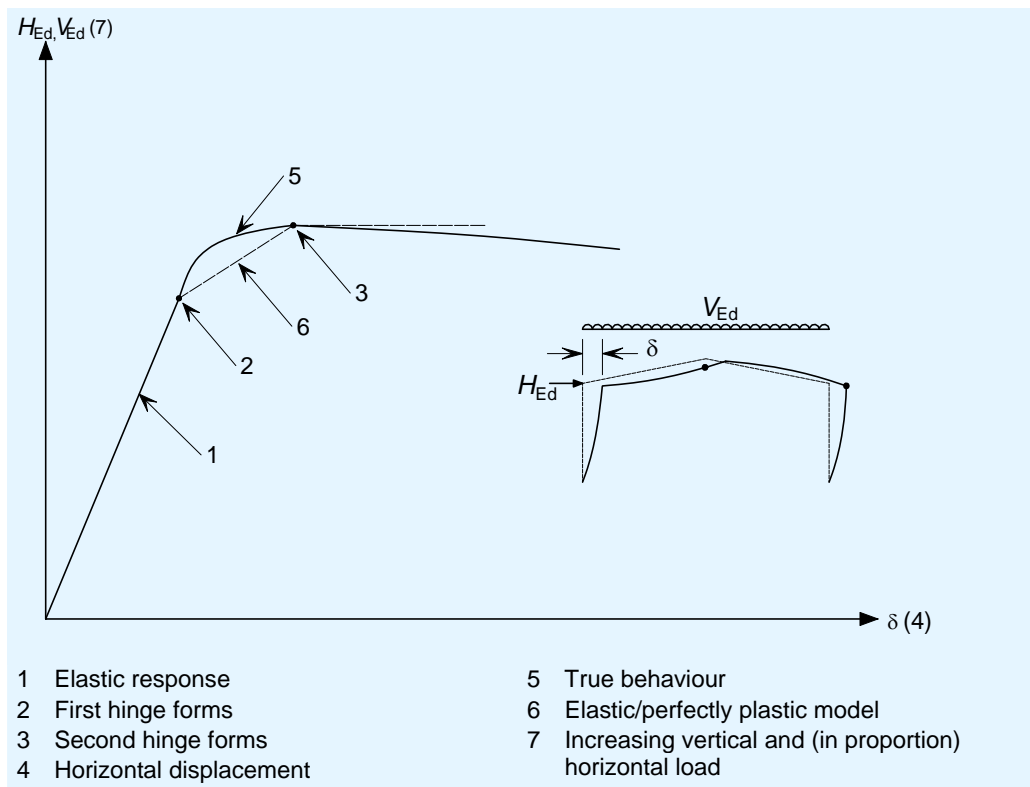

Figure 3.5 Simple model of a portal frame subject to increasing vertical and horizontal loads, with failure governed by a sway mechanism

The elastic-perfectly-plastic model, Figure 3.4, assumes that the members deform as linear elastic elements until the applied moment reaches the full plastic moment M_p . The subsequent behaviour is assumed to be perfectly plastic without strain hardening.

With elastic-perfectly-plastic analysis, the load is applied in small increments, with hinges inserted in the analysis model at any section that reaches its full plastic moment, M_p as illustrated in Figure 3.6. If the appropriate computer software is used, it should be possible to predict hinges that form, rotate, then unload or even reverse. The final mechanism will be the true collapse mechanism and will be identical to the lowest load factor mechanism that can be found by the rigid-plastic method.

The elastic/perfectly-plastic method has the following advantages:

- The true collapse mechanism is identified.
- All plastic hinges are identified, including any that might form and subsequently unload. Such (transient) hinges would not appear in the final collapse mechanism but would nevertheless need restraint.
- Hinges forming at loads greater than ULS can be identified. Such hinges do not need restraint, as the structure can already carry the ULS loads. This may produce economies in structures where the member resistance is greater than necessary, as occurs when deflections govern the design or when oversize sections are used.
- The true bending moment diagram at collapse, or at any stage up to collapse, can be identified.

3.2.4 Elastic vs. plastic analysis

As discussed in Section 3.1, plastic analysis generally results in more economical structures because plastic redistribution allows smaller members to carry the same loads. For frames analysed plastically, haunch lengths are generally around 10% of the span.

Where deflections (SLS) govern design, there is no advantage in using plastic analysis for the ULS. If stiffer sections are selected in order to control deflections, it is quite possible that no plastic hinges form and the frame remains elastic at ULS.

The economy of plastic analysis also depends on the bracing system, because plastic redistribution imposes additional requirements on the restraint to members, as discussed in Section 6.3. The overall economy of the frame might, therefore, depend on the ease with which the frame can be restrained.

Plastic analysis should only be contemplated if commercial software is available. The more sophisticated software packages carry out second order ($P-\Delta$) elastic-plastic analysis directly, significantly simplifying the overall design process. The ready availability of elastic/plastic design software makes it as easy to adapt full plastic analysis. The resulting limitation to Class 1 sections, which are required at potential hinge positions, is not significant.

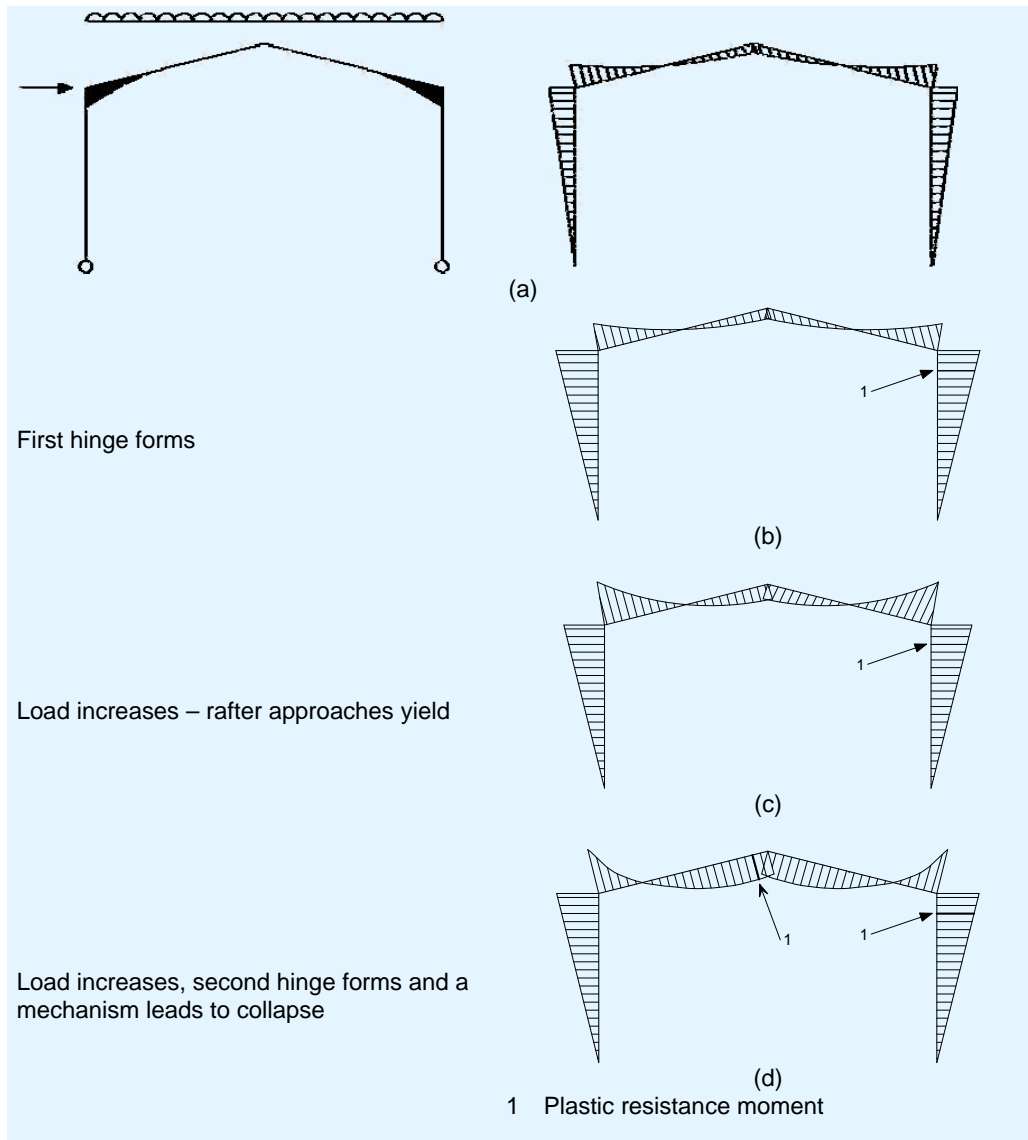

Figure 3.6 Elastic-perfectly-plastic method of analysis, showing state of frame as horizontal and vertical loads are increased proportionally
a) Elastic throughout; (b) Plastic hinge at eaves; (c) Rafters approaching plasticity; (d) Plastic hinge in rafter

It is recognised that some redistribution of moments is possible, even with the use of elastic design. EN 1993-1-1 § 5.4.1.4(B) allows 15% redistribution, as discussed in Section 3.2.2, although this is uncommon in practice.

Where haunch lengths of around 15% of the span are acceptable and the lateral loading is small, the elastic bending moment diagram will be almost the same as the plastic collapse bending moment diagram. As illustrated in Figure 3.3, the maximum hogging moment at the end of the haunch is similar to the maximum sagging moment in the rafter. In such cases, an elastic analysis may provide an equivalent solution to a plastically analysed frame.

3.3 First order and second order analysis

For both plastic analysis and elastic analysis of frames, the choice of first-order or second order analysis may be governed by the in-plane flexibility of the frame, measured by the factor α_{cr} (see Section 3.3.1). In practice, the choice between first and second order analysis is also dependent on the availability of software. Even if a portal frame was sufficiently stiff that second order effects were small enough to be ignored, it may be convenient still to use second order analysis software.

When a second order analysis is required but is not available, modified first order methods can be useful for calculations. A modified first order approach is slightly different for elastic and plastic analysis, and is described in Sections 3.3.2 and 3.3.3. In elastic analysis, the horizontal actions are amplified; in plastic analysis, all actions are amplified.

3.3.1 α_{cr} factor

Expression 5.2 of EN 1993-1-1 § 5.2.1(4)B gives α_{cr} as:

$$\alpha_{cr} = \left(\frac{H_{Ed}}{V_{Ed}} \right) \left(\frac{h}{\delta_{H,Ed}} \right)$$

Note 1B and Note 2B of that clause limit the application of Expression 5.2 to roofs with shallow roof slopes and where the axial force in the rafter is not significant. Thus:

- a roof slope is considered as shallow at slopes no steeper than 26°
- axial force in the rafter may be assumed to be significant if $\bar{\lambda} \geq 0,3 \sqrt{\frac{Af_y}{N_{Ed}}}$.

A convenient way to express the limitation on the axial force is that the axial force is not significant if:

$$N_{Ed} \leq 0.09N_{cr}$$

Where

N_{cr} is the elastic critical buckling load for the complete span of the rafter pair, i.e. $N_{cr} = \frac{\pi^2 EI}{L^2}$

L is the developed length of the rafter pair from column to column, taken as span/Cos θ (θ is the roof slope)

If the limits are satisfied, then Expression 5.2 may be used to calculate α_{cr} . In most practical portal frames, the axial load in the rafter will be significant and Expression 5.2 cannot be used.

When the axial force in the rafter is significant, Appendix B provides an alternative, approximate method to calculate the measure of frame stability, defined as $\alpha_{cr,est}$. In many cases, this will be a conservative result. Accurate values of α_{cr} may be obtained from software.

3.3.2 Modified first order, for elastic frame analysis

The ‘amplified sway moment method’ is the simplest method of allowing for second order effects for elastic frame analysis; the principle is given in EN 1993-1-1, § 5.2.2(5B).

A first-order linear elastic analysis is first carried out; then all horizontal loads are increased by an amplification factor to allow for the second order effects. The horizontal loads comprise the externally applied loads, such as the wind load, and the equivalent horizontal forces used to allow for frame imperfections; both are amplified.

Provided $\alpha_{cr} \geq 3,0$ the amplification factor is:

$$\left(\frac{1}{1 - 1/\alpha_{cr}} \right)$$

If the axial load in the rafter is significant, and $\alpha_{cr,est}$ has been calculated in accordance with Appendix B, the amplifier becomes:

$$\left(\frac{1}{1 - 1/\alpha_{cr,est}} \right)$$

If α_{cr} or $\alpha_{cr,est}$ is less than 3,0 second order software should be used.

3.3.3 Modified first order, for plastic frame analysis

Design philosophy

In the absence of elastic-plastic second order analysis software, the design philosophy is to derive loads that are amplified to account for the effects of deformed geometry (second order effects). Application of these amplified loads through a first-order analysis gives the bending moments, axial forces and shear forces that include the second order effects approximately.

The amplification is calculated by a method that is sometimes known as the Merchant-Rankine method. Because, in plastic analysis, the plastic hinges limit the moments resisted by the frame, the amplification is performed on all the actions that are applied to the first-order analysis (i.e. all actions and not only the horizontal forces related to wind and imperfections).

The Merchant-Rankine method places frames into one of two categories:

- Category A: Regular, symmetric and mono-pitched frames
- Category B: Frames that fall outside of Category A but excluding tied portals.

For each of these two categories of frame, a different amplification factor should be applied to the actions. The Merchant-Rankine method has been verified for frames that satisfy the following criteria:

1. Frames in which $\frac{L}{h} \leq 8$ for any span
2. Frames in which $\alpha_{cr} \geq 3$

where:

- L is span of frame (see Figure 3.7)
- h is the height of the lower column at either end of the span being considered (see Figure 3.7)
- α_{cr} is the elastic critical buckling load factor.

If the axial load in the rafter is significant (see Section 3.3.1), $\alpha_{cr,est}$ should be calculated in accordance with Appendix B).

Other frames should be designed using second order elastic-plastic analysis software.

Amplification factors

Category A: Regular, symmetric and nearly symmetric pitched and mono-pitched frames (See Figure 3.7).

Regular, symmetric and mono-pitched frames include single span frames and multi-span frames in which there is only a small variation in height (h) and span (L) between the different spans; variations in height and span of the order of 10% may be considered as being sufficiently small.

In the traditional industrial application of this approach, first-order analysis may be used for such frames if all the applied actions are amplified by $\left(\frac{1}{1-1/\alpha_{cr}}\right)$, or $\left(\frac{1}{1-1/\alpha_{cr,est}}\right)$ if the axial force in the rafter was found to be significant.

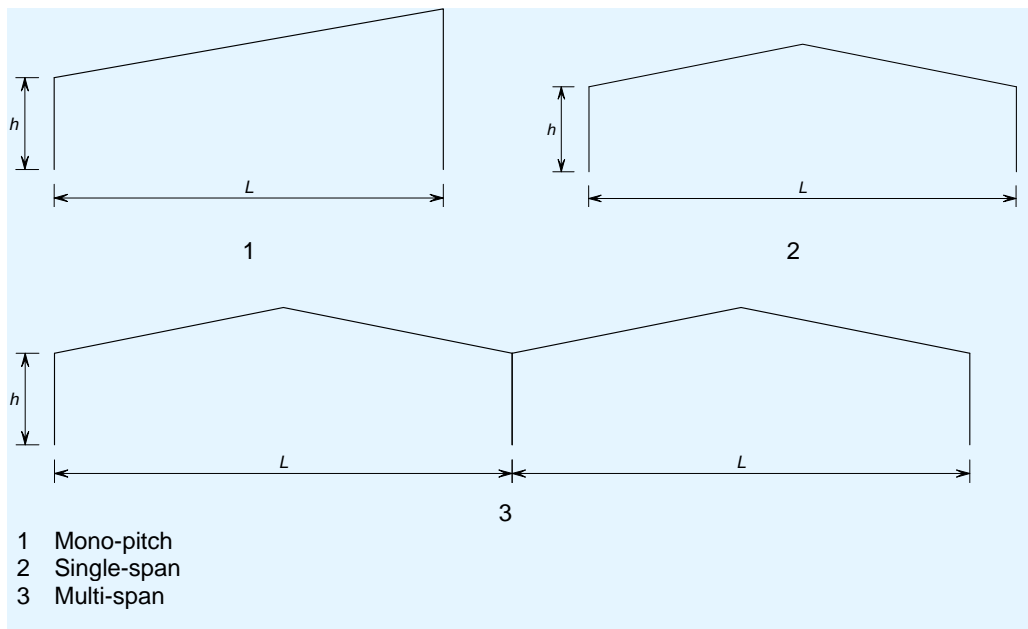

Figure 3.7 Examples of Category A frames

Category B: Frames that fall outside of Category A (See Figure 3.8), but excluding tied portals.

For frames that fall outside of Category A, first-order analysis may be used if all the applied loads are amplified by:

$\left(\frac{1,1}{1-1/\alpha_{cr}}\right)$ or $\left(\frac{1,1}{1-1/\alpha_{cr,est}}\right)$ if the axial force in the rafter was found to be significant.

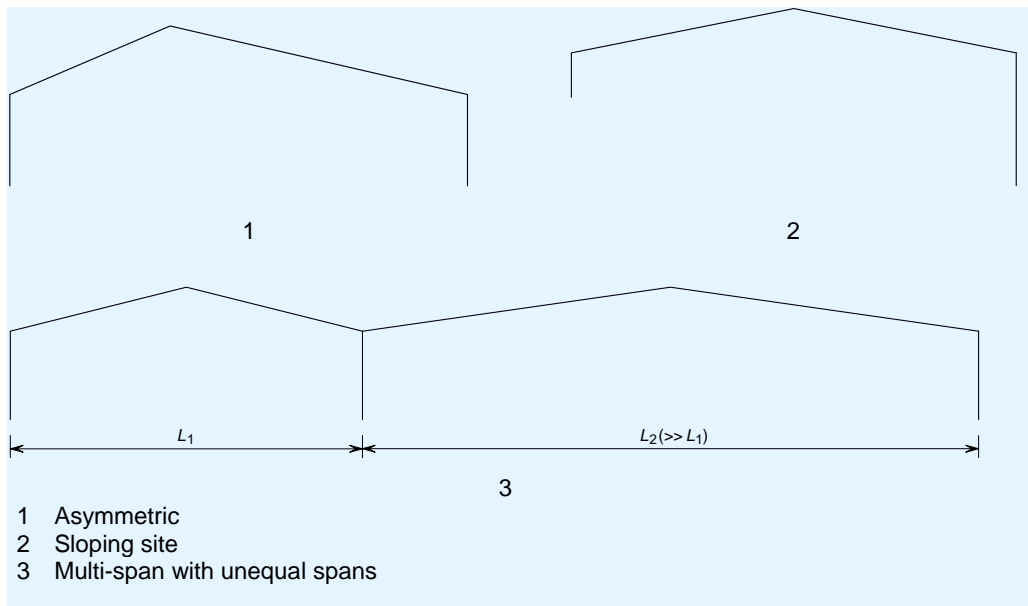

Figure 3.8 Examples of Category B frames

3.4 Base stiffness

Analysis should take account of the rotational stiffness of the bases. The following simple rules in this section are recommended. These recommendations might not be accepted in certain countries; the relevant National Annex and the local regulatory authorities should be consulted.

It is important to distinguish between column base resistance and column base stiffness. Column base resistance is only relevant to elastic-plastic or rigid-plastic calculations of frame resistance, not to deflections. Column base stiffness is relevant to elastic-plastic or elastic frame analysis for both resistance and deflection.

If any base stiffness is assumed in ULS design, the base details and foundation must be designed to have sufficient resistance to sustain the calculated moments and forces.

In many general analysis computer programmes, these base stiffnesses are most conveniently modelled by the introduction of a dummy member, as shown in Figure 3.9.

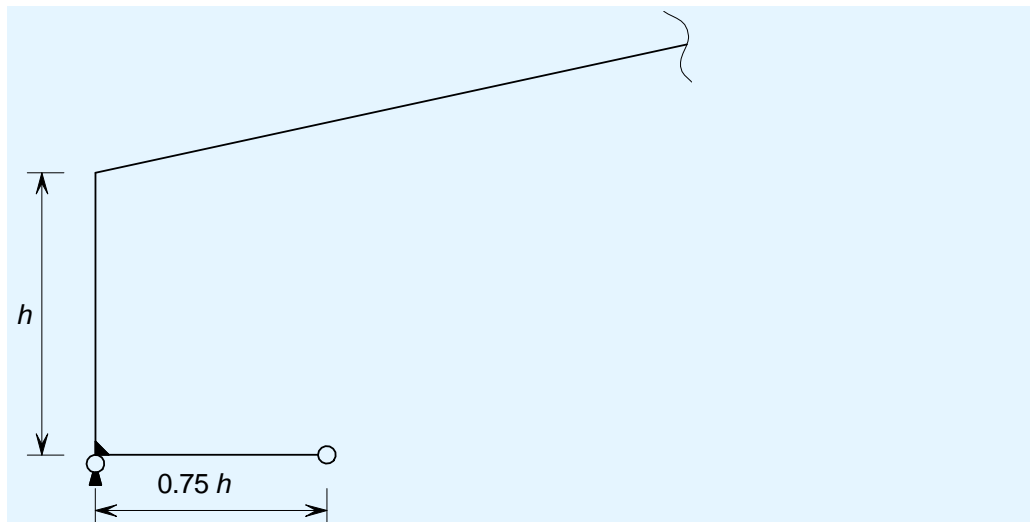

Figure 3.9 Dummy member to model nominally rigid column base

Note that the reaction at the pinned end of the dummy member will affect the reaction at the column base. This must be corrected by taking the base reaction equal to the axial force in the column, which equals the sum of the reactions at the base and the pinned end of the dummy member.

3.4.1 Pinned and rocker bases

Where a true pin or rocker is used, as illustrated in Figure 3.10, the rotational stiffness is zero. The use of such bases is rarely justified in practice. Where they are adopted, careful consideration needs to be given to the transfer of shear into the foundation, and temporary stability of the column during erection.

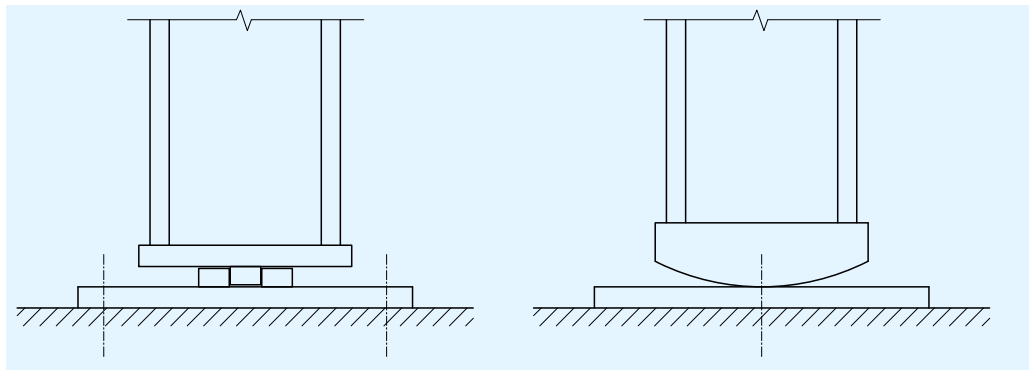

Figure 3.10 Examples of zero stiffness column bases

3.4.2 Nominally rigid column bases

If a column is rigidly connected to a suitable foundation, the following recommendations should be adopted:

Elastic global analysis:

For Ultimate Limit State calculations the stiffness of the base can be taken as equal to the stiffness of the column.

For Serviceability Limit State calculations the base can be treated as rigid to determine deflections under serviceability loads.

Plastic global analysis:

Any base moment capacity between zero and the plastic moment capacity of the column may be assumed, provided that the foundation is designed to resist a moment equal to this assumed moment capacity, together with the forces obtained from the analysis.

Elastic - plastic global analysis:

The assumed base stiffness must be consistent with the assumed base moment capacity, but should not exceed the stiffness of the column.

3.4.3 Nominally semi-rigid column bases

A nominal base stiffness of up to 20 % of the column may be assumed in elastic global analysis, provided that the foundation is designed for the moments and forces obtained from this analysis.

3.4.4 Nominally pinned bases

If a column is nominally pin – connected to a foundation that is designed assuming that the base moment is zero, the base should be assumed to be pinned when using elastic global analysis to calculate the other moments and forces in the frame under Ultimate Limit State loading.

The stiffness of the base may be assumed to be equal to the following proportion of the column stiffness:

- 10% when calculating α_{cr} or $\alpha_{cr,est}$
- 20% when calculating deflections under serviceability loads.

Column base plates with a relatively thin base plate and four bolts outside the profile of the column section are considered in some countries as nominally pinned if they have sufficient deformation capacity, although in fact they will exhibit semi-rigid behaviour. Such bases have the additional practical advantage that they provide sufficient base stiffness to enable the column to be free-standing during erection, and assist in the aligning of the column.

3.5 Design summary

Analysis for the Ultimate Limit State:

- may be carried out either by elastic analysis or by plastic analysis
- should take account of second order ($P-\Delta$) effects, when α_{cr} or $\alpha_{cr,est}$ is less than 10 (elastic analysis) or 15 (plastic analysis)
- if necessary, second order effects can be accounted for either directly (using a second order analysis) or by the use of a modified first order analysis with an amplification factor.

For most structures, greatest economy (and ease of analysis and design) will be achieved by the use of software that:

- is based on elastic/perfectly plastic moment/rotation behaviour
- takes direct account of second order ($P-\Delta$) effects.

A summary of the assessment of sensitivity to second order effects and the amplification to allow for second order effects is given in Table 3.1.

Table 3.1 Second order effects: assessment and amplification factors

	Restrictions	Elastic analysis	Plastic analysis
Measure of sensitivity to second order effects	shallow slopes, and rafter axial force not significant	α_{cr}	α_{cr}
	steep slopes, and rafter axial force significant	$\alpha_{cr,est}$	$\alpha_{cr,est}$
Amplifier to allow for second order effects	Regular frames	$\left(\frac{1}{1-1/\alpha_{cr}} \right)$ or	$\left(\frac{1}{1-1/\alpha_{cr}} \right)$ or
		$\left(\frac{1}{1-1/\alpha_{cr,est}} \right)$	$\left(\frac{1}{1-1/\alpha_{cr,est}} \right)$
	Irregular frames, but excluding tied portals	$\left(\frac{1}{1-1/\alpha_{cr}} \right)$ or	$\left(\frac{1,1}{1-1/\alpha_{cr}} \right)$ or
		$\left(\frac{1}{1-1/\alpha_{cr,est}} \right)$	$\left(\frac{1,1}{1-1/\alpha_{cr,est}} \right)$
Amplifier applied to:		Horizontal loads only	All loads

4 SERVICEABILITY LIMIT STATE

4.1 General

The Serviceability Limit State (SLS) analysis should be performed using the SLS load cases, to ensure that the deflections are acceptable at ‘working loads’.

4.2 Selection of deflection criteria

No specific deflection limits are set in EN 1993-1-1. According to EN 1993-1-1 § 7.2 and EN 1990, Annex A1.4, deflection limits should be specified for each project and agreed with the client. The relevant National Annex to EN 1993-1-1 may specify limits for application in individual countries. Where limits are specified they have to be satisfied. Where limits are not specified, Appendix A of this document presents typical limits.

If the structure contains overhead travelling cranes, the spread of the columns at the level of the crane is likely to be an important design criterion. In many cases, it will be necessary to provide stiffer steel sections than are necessary for the ULS design, or to provide some fixity in the base and foundation. An alternative is a tied portal (when second order analysis must be used) or a truss.

4.3 Analysis

The SLS analysis is normally a first-order (elastic) analysis. The designer should verify plastic hinges do not form at SLS, simply to validate the deflection calculations.

4.4 Design summary

The Serviceability Limit State (SLS):

- Is assessed by first order analysis
- Uses deflection criteria defined in the relevant National Annex or agreed with the client.

5 CROSS-SECTION RESISTANCE

5.1 General

EN 1993-1-1 requires that the resistance of cross-sections and the member buckling resistance are checked by separate calculations. Additional checks are required for the resistance of webs to shear buckling and buckling due to transverse loads.

The calculated resistance depends on the classification of the cross-section. Cross-section resistance is treated in Section 6.2 of EN 1993-1-1.

5.2 Classification of cross-section

In EN 1993-1-1, cross-sections are classified according to the relative thickness of the flanges and web, together with the magnitude of the bending moment and axial compression on the section. The classification according to the slenderness of flange or web elements is given in EN 1993-1-1 Table 5.2. EN 1993-1-1 covers sections under axial load alone, under pure bending and under combined axial load and bending moment. The class of a section is the highest class of either the flanges or the web.

It is important to note that the classification depends on both the geometry of the cross-section and the ratio of the moments and axial force at the cross-section. For example, a typical I-beam might be Class 1 under pure moment but Class 2 or 3 under pure axial loading; under combined loading it might then be Class 1, 2, or 3, depending on the proportions of axial force and bending moment at the cross-section under consideration.

The classes indicate the following structural behaviour:

- Class 1 can support a rotating plastic hinge without any loss of resistance from local buckling.
- Class 2 can develop full plastic moment but with limited rotation capacity before local buckling reduces resistance.
- Class 3 can develop yield in extreme fibres but local buckling prevents development of plastic moment.
- Class 4 has proportions such that local buckling will occur at stresses below first yield.

5.3 Member ductility for plastic design

As specified in EN 1993-1-1:2005 § 5.6, all members formed from rolled sections (and therefore uniform apart from haunches) containing plastic hinges that rotate prior to reaching the ULS loading must have a Class 1 cross-section. Elsewhere, they may be Class 2.

§ 5.6(3) provides additional requirements for non-uniform sections, i.e. the rafters and their haunches. These will automatically be satisfied by the general requirement for uniform sections in the paragraph above where the haunch is formed from a cutting from the rafter section, or cut from a slightly larger rolled section.

5.4 Design summary

- Cross-section classification depends on the ratio of moment and axial load.
- All critical cross-sections need to be checked for cross-section resistance in accordance with Section 6.2 of EN 1993-1-1.
- For plastic design, all sections containing plastic hinges must be Class 1.

6 MEMBER STABILITY

6.1 Introduction

Members must be checked for the combined effects of axial load and buckling. In general, this will be by satisfying Expressions 6.61 and 6.62 of EN 1993-1-1, as described in Section 6.2. In the special circumstances where there are plastic hinges in members, EN 1993-1-1 gives particular requirements, as described in Section 6.4.

In-plane buckling is buckling about the major axis of the member. As explained in Section 6.1.1, there are no intermediate restraints when considering in-plane buckling of a member in a portal frame.

Out-of-plane buckling concerns buckling about the minor axis of the member. In a portal frame the secondary steelwork can be used to provide restraints, and so increase the buckling resistance, as described in Section 6.3.

6.1.1 Member buckling in portal frames

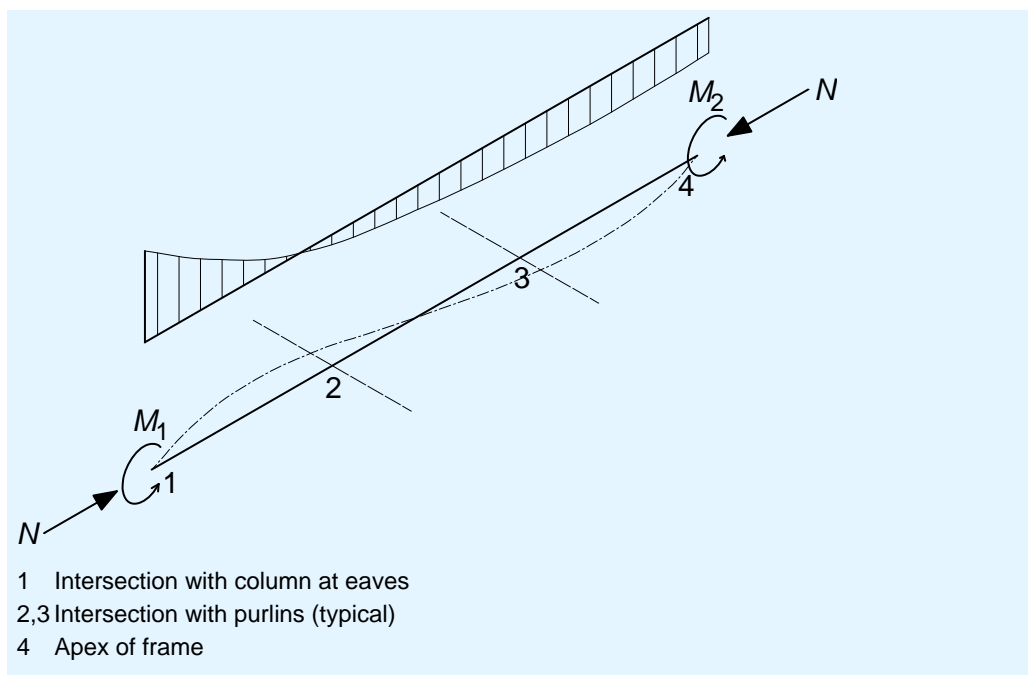

Figure 6.1 Diagrammatic representation of a portal frame rafter

Figure 6.1 shows a simple representation of the issues that need to be addressed when considering the stability of a member within a portal frame, in this example a rafter between the eaves and apex. The following points should be noted:

- There can be no intermediate points of restraint for in-plane buckling between the main nodes of the frame, 1 and 4.
- Intermediate restraints may be introduced (nodes 2 and 3) against out-of-plane buckling.

Practical design addresses this interaction in several ways:

- Out-of-plane stability near plastic hinges is generally addressed by the concept of stable lengths, L_{stable} , L_m , L_k and L_s . These are assumed to be independent of any interaction with in-plane stability effects (see Section 6.4.).
- Interaction between bending moment and axial load is addressed by simultaneously satisfying Expressions 6.61 and 6.62 of EN 1993-1-1. This is usually undertaken by considering the most onerous out-of-plane check (from any part of the member) with the relevant in-plane check.

6.2 Buckling resistance in EN 1993-1-1

The verification of buckling resistance of members is addressed by several clauses in EN 1993-1-1. The clauses of primary interest in portal frame design are described below.

6.3.1 Uniform members in compression. This clause covers strut buckling resistance and the selection of buckling curves. The clause is primarily concerned with flexural buckling, but also addresses torsional and torsional-flexural buckling. These latter modes of failure will not govern the IPE sections and similar cross-sections adopted for portal frames.

6.3.2 Uniform members in bending. This clause covers lateral-torsional buckling of beams.

The distribution of bending moments along an unrestrained length of beam has an important influence on the buckling resistance. This is accounted for by the choice of C_1 factor when calculating M_{cr} (See Appendix C).

6.3.3 Uniform members in bending and axial compression. This clause addresses the interaction of axial load and moment, in-plane and out-of-plane.

The clause requires the following checks to be carried out unless full second order analysis, including all member imperfections ($P-\delta$, torsional and lateral imperfections), is utilised.

$$\frac{\frac{N_{Ed}}{\chi_y N_{Rk}} + k_{yy} \frac{M_{y,Ed} + \Delta M_{y,Ed}}{\chi_{LT} \frac{M_{y,Rk}}{\gamma_{M1}}} + k_{yz} \frac{M_{z,Ed} + \Delta M_{z,Ed}}{\gamma_{M1}}}{\gamma_{M1}} \leq 1 \quad (6.61)$$

$$\frac{\frac{N_{Ed}}{\chi_z N_{Rk}} + k_{zy} \frac{M_{y,Ed} + \Delta M_{y,Ed}}{\chi_{LT} \frac{M_{y,Rk}}{\gamma_{M1}}} + k_{zz} \frac{M_{z,Ed} + \Delta M_{z,Ed}}{\gamma_{M1}}}{\gamma_{M1}} \leq 1 \quad (6.62)$$

For Class 1, 2, 3 and bi-symmetric Class 4 sections, $\Delta M_{y,Ed} = \Delta M_{z,Ed} = 0$

It is helpful to define $\chi_y \frac{N_{y,Rk}}{\gamma_{M1}}$ as $N_{b,y,Rd}$ and $\chi_{LT} \frac{M_{y,Rk}}{\gamma_{M1}}$ as $M_{b,Rd}$.

$M_{z,Ed}$ is zero because the frame is only loaded in its plane.

The expressions therefore simplify to:

$$\frac{N_{Ed}}{N_{b,y,Rd}} + \frac{k_{yy}M_{y,Ed}}{M_{b,Rd}} \leq 1.0 \text{ (from Expression 6.61)}$$

and
$$\frac{N_{Ed}}{N_{b,z,Rd}} + \frac{k_{zy}M_{y,Ed}}{M_{b,Rd}} \leq 1.0 \text{ (from Expression 6.62).}$$

Values of k_{yy} and k_{zy} may be obtained from EN 1993-1-1, either Annex A or Annex B. Annex A generally provides higher design strength for the rafters and columns in portal frames than Annex B. The choice of Annex may be defined in some countries by their National Annexes. The worked example within this publication adopts Annex B values.

The buckling resistances will normally be based on the system length of the rafter and column. Some national regulatory authorities may allow the use of a reduced system length and a buckling length factor. The buckling length factor is 1.0 or smaller, and reflects the increased buckling resistance of members with a degree of end fixity. The buckling length is the product of the length and the buckling length factor, and will be less than the system length. This approach will result in an enhanced buckling resistance.

Clause 6.3.5 Lateral torsional buckling of members with plastic hinges. This clause provides guidance for the members in frames that have been analysed plastically. The clause requires restraint to hinge locations and verification of stable lengths between such restraints and other lateral restraints. Both topics are addressed in more detail in Section 6.4.

6.2.1 Influence of moment gradient

A uniform bending moment is the most onerous loading system when calculating the lateral torsional buckling resistance of a member. A non-uniform moment is less onerous. Annexes A and B in EN 1993-1-1 allow for the effect of the moment gradient, via coefficients $C_{mi,0}$ and C_{mLT} etc. These C factors influence the k_{yy} and k_{zy} factors in Expressions 6.61 and 6.62, used when verifying the member.

Although it is conservative to take C factors as 1.0, this is not recommended.

6.3 Out-of-plane restraint

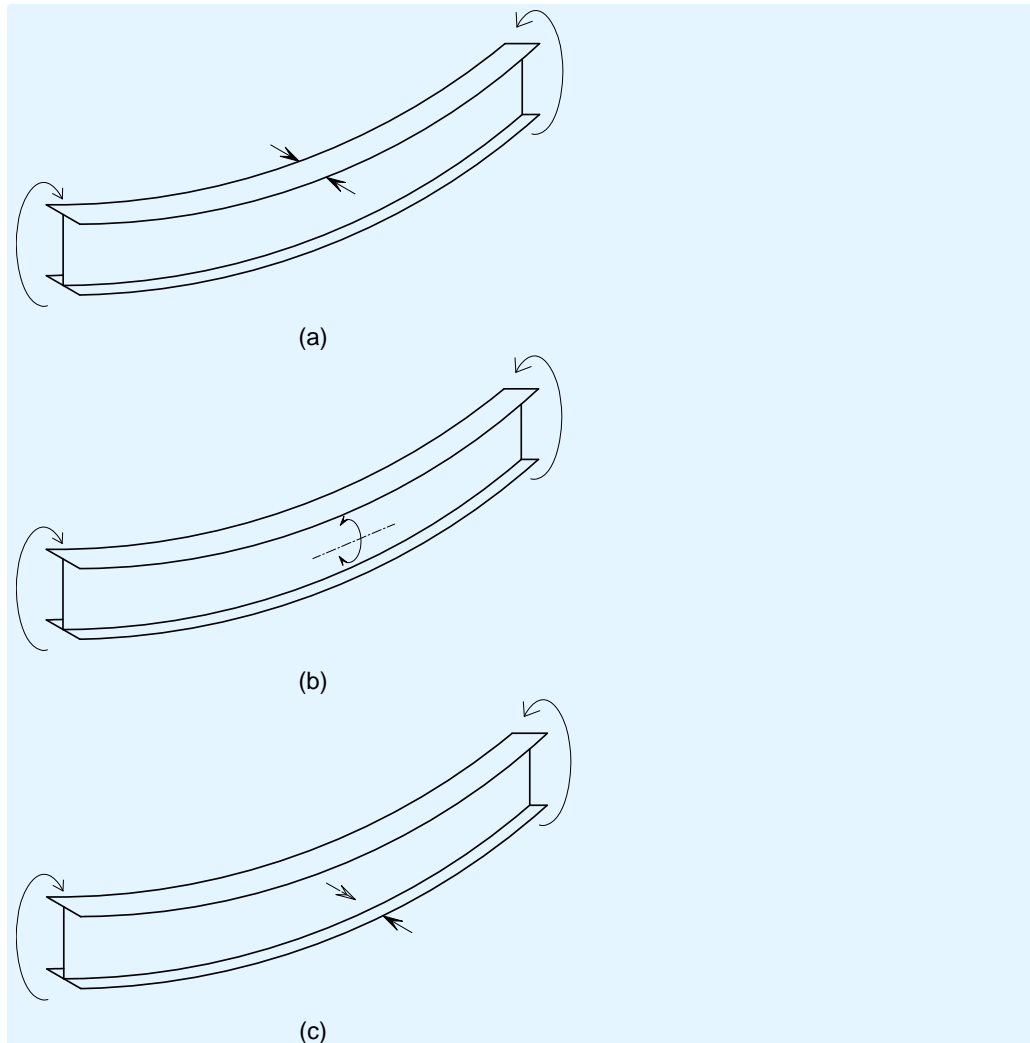

Figure 6.2 Types of restraint to out-of-plane buckling

Figure 6.2 shows the three basic types of restraint that can be provided to reduce or prevent out-of-plane buckling:

- (a) Lateral restraint, which prevents lateral movement of the compression flange.
- (b) Torsional restraint, which prevents rotation of a member about its longitudinal axis.
- (c) Intermediate lateral restraint to the tension flange. Such restraints are only of limited benefit, but do modify the out-of-plane buckling mode and may therefore allow the distance between torsional restraints to be increased.

As shown in Figure 6.3, practical details may provide more than one type of restraint.

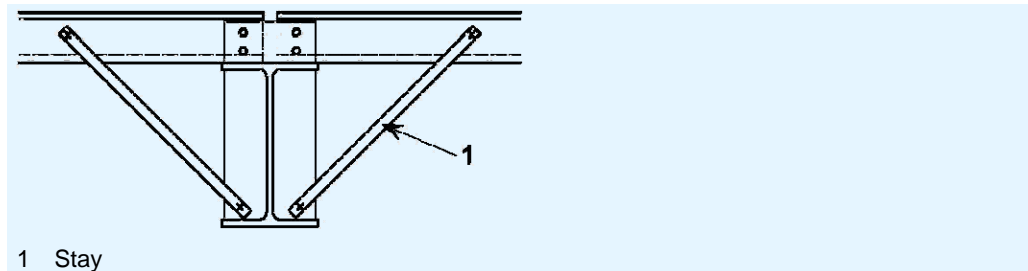

Figure 6.3 Example of combined lateral and torsional restraint

Purlins attached to the top flange of the rafter and side rails attached to the outer flange of the column provide stability to the rafter in a number of ways:

- Direct lateral restraint, when the outer flange is in compression.
- Intermediate lateral restraint to the tension flange between torsional restraints, when the outer flange is in tension.
- Torsional and lateral restraint to the rafter when the purlin is attached to the tension flange and used in conjunction with rafter stays to the compression flange.

In all cases, the purlins and side rails should be tied back into a system of bracing in the plane of the rafters (see Section 9). Generally, the assumption that the forces are carried back to the bracing system via the roof diaphragm is accepted in many countries, even without supporting calculations. In other countries calculations are necessary, or the purlins can only be assumed to provide restraint if they are aligned directly with the bracing system.

The position of the purlins and side rails will be a balance between the capacity of the purlins themselves, and the necessary spacing required to restrain the primary steel members. The maximum spacing will usually be determined from manufacturers' load tables. Spacing may have to be reduced to provide restraint to the inside flange at strategic points along the rafter or column, so it would be common to provide purlins at reduced spacing in zones of high bending moment, such as around the eaves haunch.

Normal practice is to locate one purlin at the 'sharp' end of the haunch, and one near the apex. The intervening length is split at regular spacing – typically about 1,6 to 1,8 m. A purlin is often located near the end plate of the rafter, and depending on the length of the haunch, one, two or more purlins in the length to the 'sharp' end of the haunch, usually at lesser spacing than the main length of rafter.

Additional purlins may be required to carry drifted snow – these may also be used to provide restraint.

Side rails are usually located at positions to suit the cladding, doors and windows. The inside of the flange at the underside of the haunch always requires restraint – it is common to position a side rail at this level.

Purlins and side rails must be continuous in order to offer adequate restraint, as shown in Figure 6.3. A side rail that is not continuous (for example, interrupted by industrial doors) cannot be relied upon to provide adequate restraint.

6.4 Stable lengths adjacent to plastic hinges

6.4.1 Introduction

EN 1993-1-1 introduces four types of stable length, L_{stable} , L_m , L_k and L_s . Each is discussed below. L_k and L_s are used to verify member stability between torsional restraints and recognise the stabilising effects of intermediate restraints to the **tension** flange.

L_{stable} (Clause 6.3.5.3(1)B)

L_{stable} is the basic stable length for a uniform beam segment under linear moment and without ‘significant’ axial compression. This simple base case is of limited use in the verification of practical portal frames.

In this context, ‘significant’ may be related to the determination of α_{cr} in EN 1993-1-1 § 5.2.1 4(B) Note 2B. The axial compression is not significant if $N_{\text{Ed}} \leq 0,09N_{\text{cr}}$, as explained in Section 3.3.1

L_m (Appendix BB.3.1.1)

L_m is the stable length between the torsional restraint at the plastic hinge and the adjacent lateral restraint. It takes account of both member compression and the distribution of moments along the member. Different expressions are available for:

- Uniform members (Expression BB.5)
- Three flange haunches (Expression BB.9)
- Two flange haunches (Expression BB.10).

L_k (Appendix BB.3.1.2 (1)B)

L_k is the stable length between a plastic hinge location and the adjacent torsional restraint in the situation where a uniform member is subject to a constant moment, providing the spacing of the restraints to either the tension or compression flange is not greater than L_m . Conservatively, this limit may also be applied to a non-uniform moment.

L_s (Appendix BB.3.1.2 (2)B) and (3)B

L_s is the stable length between a plastic hinge location and the adjacent torsional restraint, where a uniform member is subject to axial compression and linear moment gradient, providing the spacing of the restraints to either the tension or compression flange is not greater than L_m .

Different C factors and different expressions are used for linear moment gradients (Expression BB.7) and non-linear moment gradients (Expression BB.8).

Where the segment varies in cross-section along its length, i.e. in a haunch, two different approaches are adopted:

- For both linear and non-linear moments on three flange haunches – BB.11
- For both linear and non-linear moments on two flange haunches – BB.12.

6.4.2 Application in practice

The flowcharts in Figures 6.4, 6.5 and 6.6 summarise the practical application of the different stable length formulae for any member segment adjacent to a plastic hinge. In the absence of a plastic hinge, the member segment is verified by conventional elastic criteria using Expressions 6.61 and 6.62.

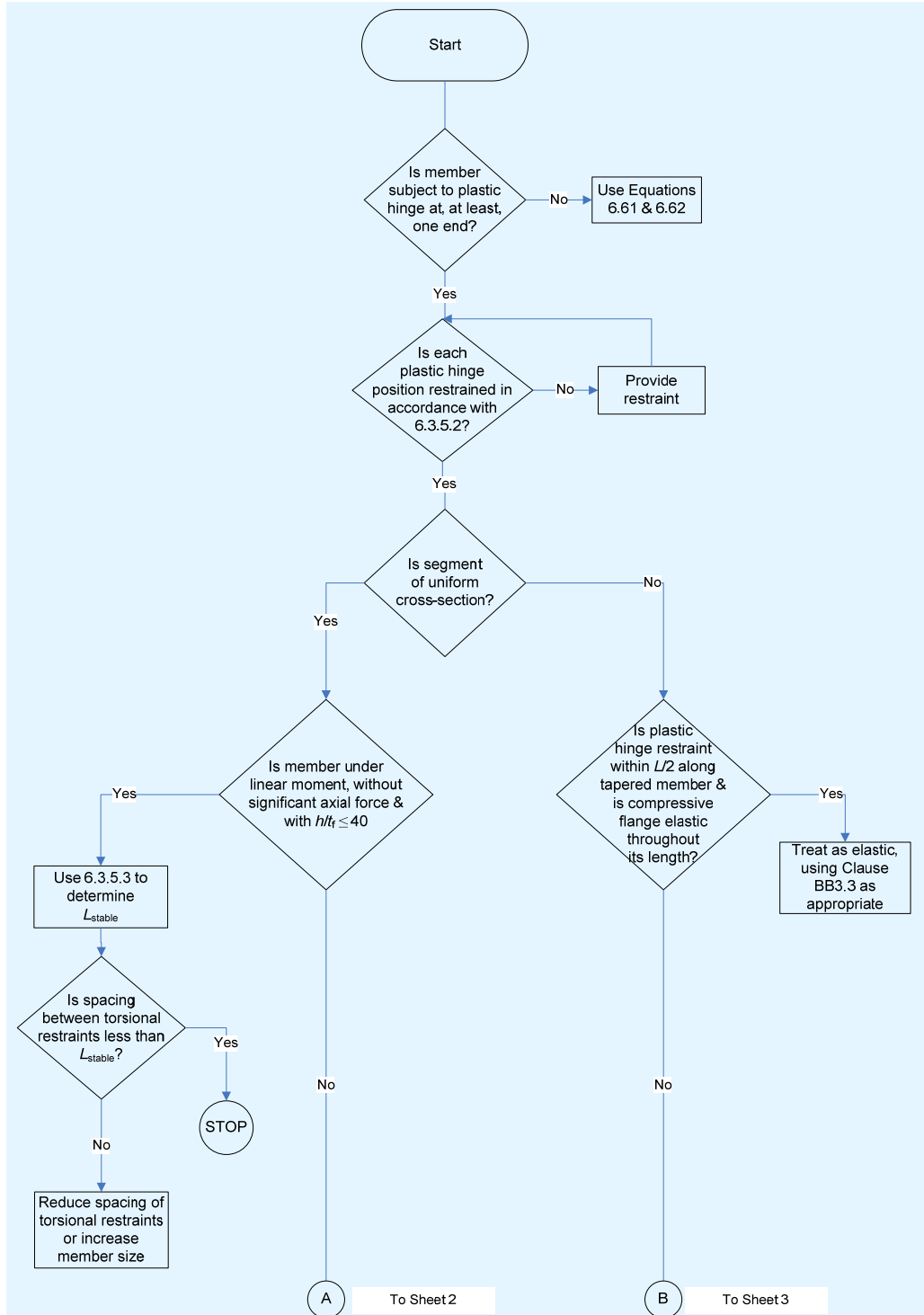

Figure 6.4 Decision tree for selecting appropriate stable length criteria for any segment in a portal frame – Sheet 1

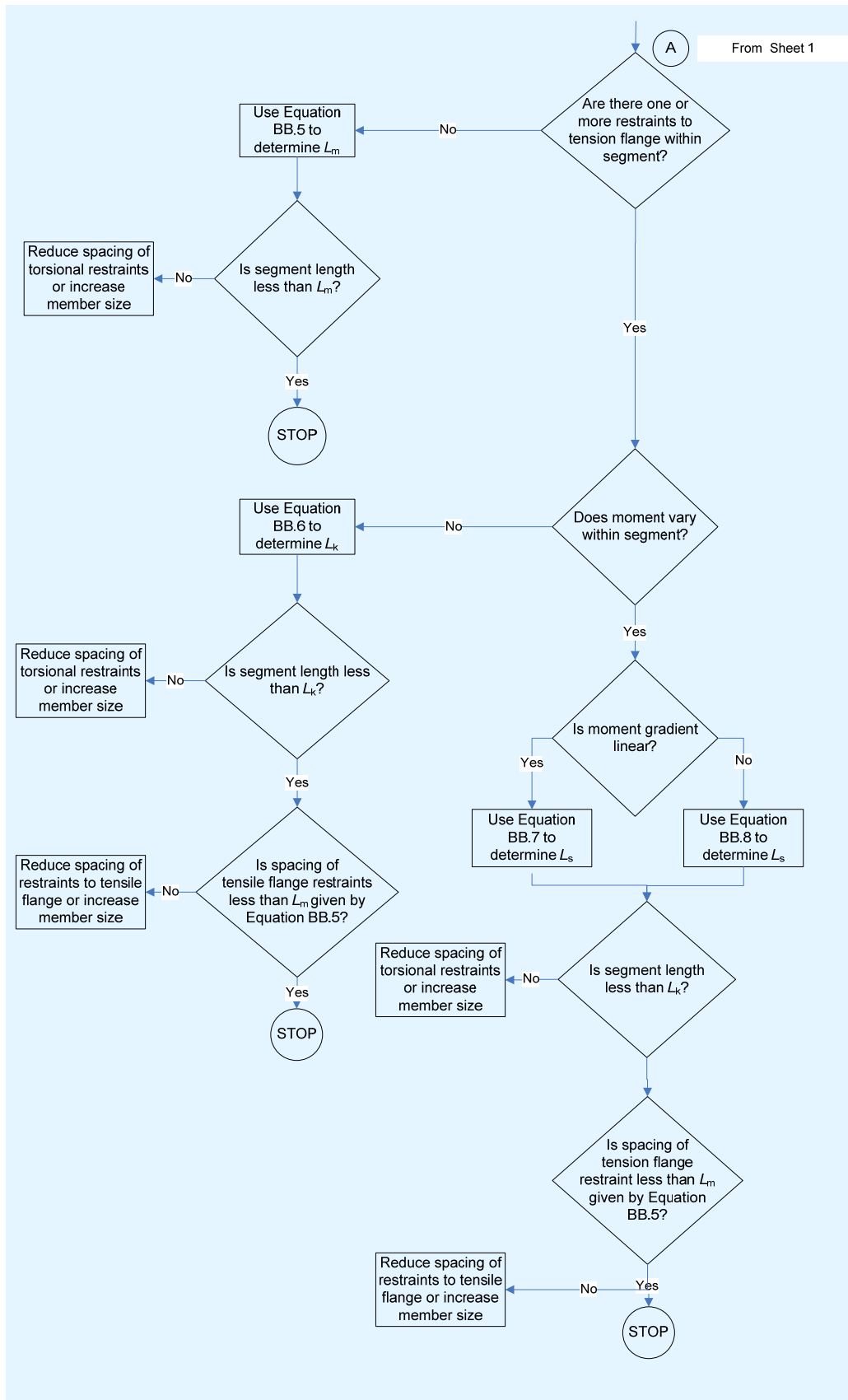

Figure 6.5 Decision tree for selecting appropriate stable length criteria for any segment in a portal frame – Sheet 2

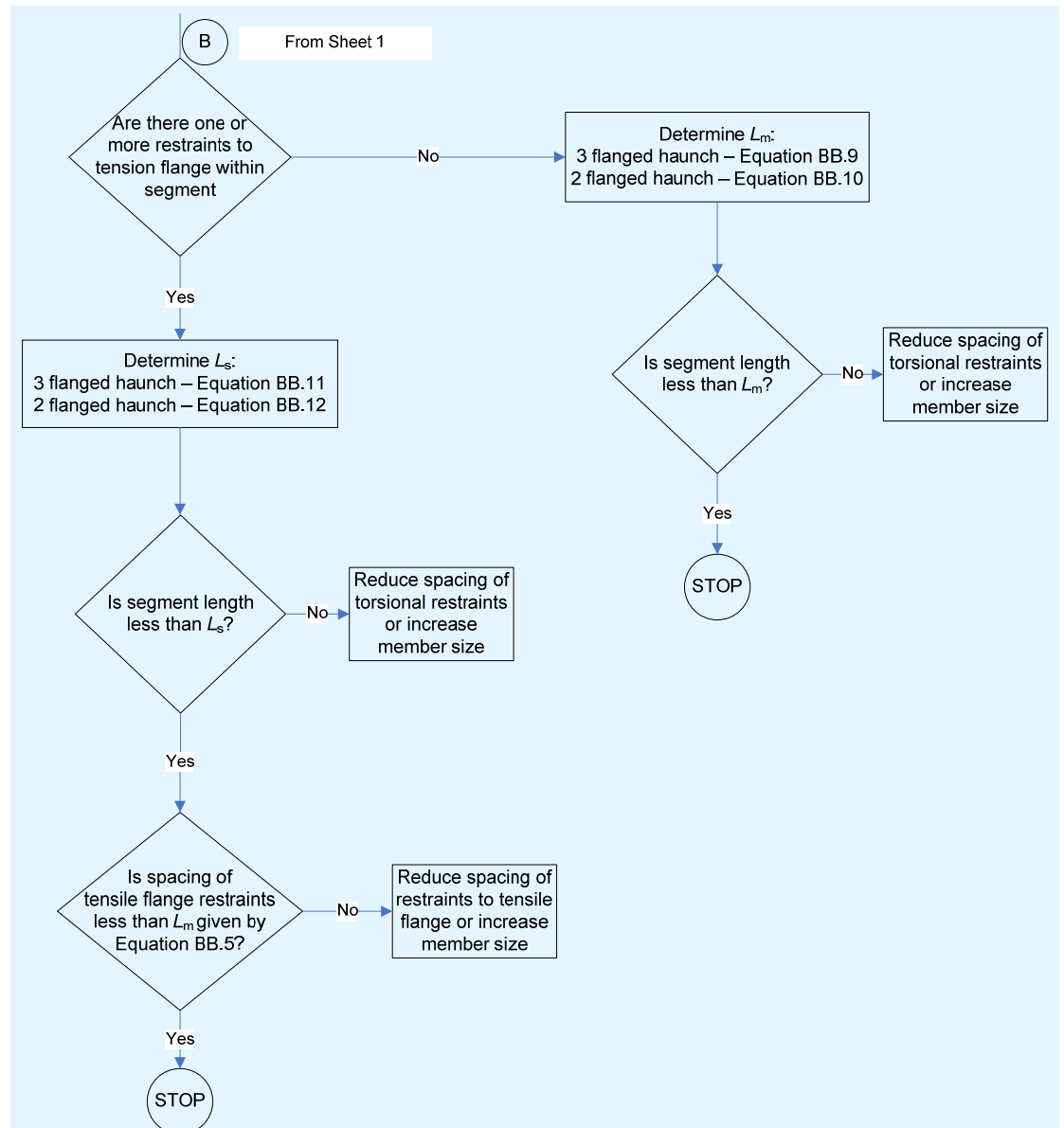

Figure 6.6 Decision tree for selection of appropriate stable length criteria in a portal frame – Sheet 3

6.5 Design summary

Before proceeding to the detailed verification of rafter and column stability, designers should appreciate that:

- Torsional and lateral restraints need to be provided at all hinge positions, as required by § 6.3.5.2.
- EN 1993-1-1 recognises four different types of stable lengths, L_{stable} , L_m , L_k and L_s , adjacent to plastic hinge positions. Lateral restraints must be provided adjacent to the hinge at no greater distance than L_{stable} or L_m and torsional restraints at no greater distance than L_k or L_s , as appropriate.
- In zones where there is no plastic hinge, each member must satisfy the simplified forms of Expressions 6.61 and 6.62. These consider in-plane and out-of-plane stability and their potential interaction.

7 RAFTER DESIGN

7.1 Introduction

Portal frame design is usually governed by the verification of members at ULS. Although SLS checks are important, orthodox frames are generally sufficiently stiff to satisfy the SLS deflection limits. Economy in the overall frame can usually be achieved by the use of plastic analysis; this requires Class 1 or 2 sections throughout and Class 1 where there is a hinge which is predicted to rotate.

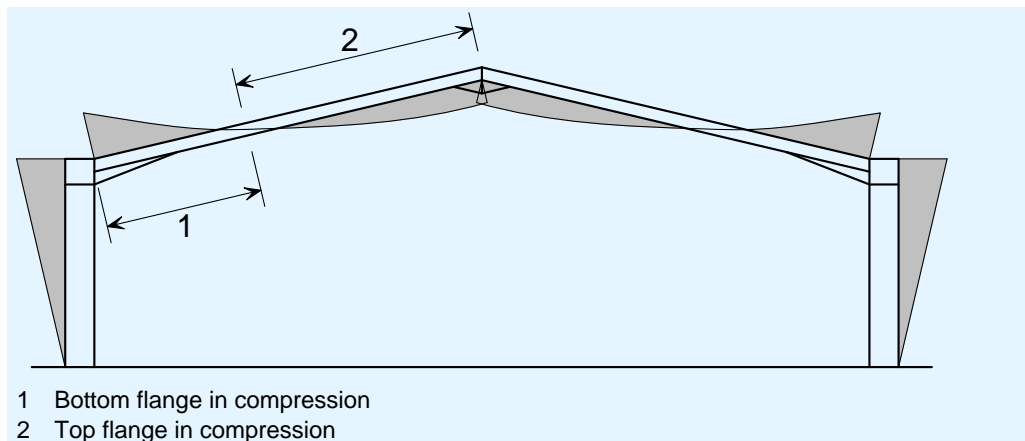

Figure 7.1 Portal frame bending moments, gravity actions

As shown in Figure 7.1, rafters are subject to high bending moments in the plane of the frame, that vary from a maximum ‘hogging’ moment at the junction with the column to a minimum sagging moment close to the apex. They are also subject to overall compression from the frame action. They are not subject to any minor axis moments.

Although member resistance is important, stiffness of the frame is also necessary to limit the effects of deformed geometry and to limit the SLS deflections. For these reasons, high strength members are generally not used in portal frames, but lower steel grades with higher inertias. Optimum design of portal frame rafters is generally achieved by use of:

- A cross-section with a high ratio of I_{yy} to I_{zz} that complies with the requirements of Class 1 or Class 2 under combined major axis bending and axial compression.
- A haunch that extends from the column for approximately 10% of the frame span. This will generally mean that the maximum hogging and sagging moments in the plain rafter length are similar.

7.2 Rafter strength

The resistances of all critical cross-sections of the rafter must be verified in accordance with Section 6 of EN 1993-1-1.

7.3 Rafter out-of-plane stability

7.3.1 Rafter and haunch stability under maximum hogging moment

Both in-plane and out-of-plane checks are required. Initially, the out-of-plane checks are completed to ensure that the restraints are located at appropriate positions and spacing.

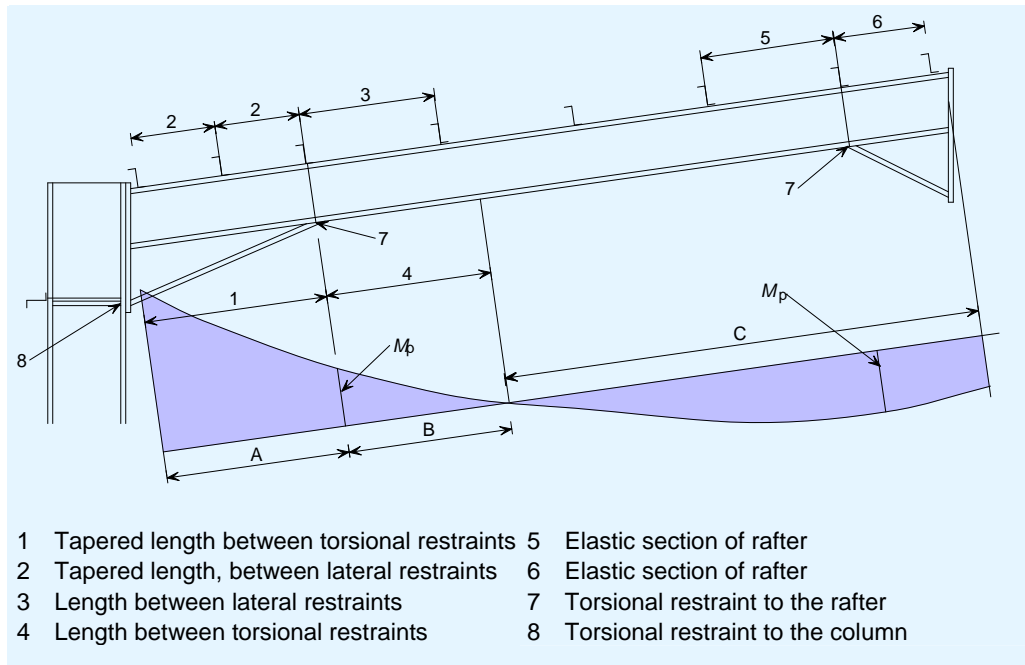

Figure 7.2 Typical portal frame rafter with potential plastic hinges at tip of haunch and first purlin down from apex

Figure 7.2 shows a typical moment distribution for permanent plus variable actions and typical purlin positions and typical restraint positions.

Purlins are placed at about 1,8 m spacing but this spacing may need to be reduced in the high moment regions near the eaves. Three stability zones are noted on Figure 7.2 (zones A, B, and C), which are referred to in the following sections.

The presence of plastic hinges in the rafter will depend on the loading, geometry and choice of column and rafter sections.

The selection of the appropriate check depends on the presence of a plastic hinge, the shape of the bending moment diagram and the geometry of the section (three flanges or two flanges). The objective of the checks is to provide sufficient restraints to ensure the rafter is stable out-of-plane.

Haunch stability in Zone A

In Zone A, the bottom flange of the haunch is in compression. The stability checks are complicated by the variation in geometry along the haunch.

The junction of the inside column flange and the underside of the haunch (point 8 in Figure 7.2) should always be restrained. The ‘sharp’ end of the haunch (point 7 in Figure 7.2) usually has restraint to the bottom flange, from a purlin located at this position, forming a torsional restraint at this point. If a

plastic hinge is predicted at this position, a restraint must be located within $h/2$ of the hinge position, where h is the depth of the rafter. In Figure 7.2, a hinge is predicted at point 7, and a restraint to the bottom flange has been provided. The restraints to each flange in the haunch region are shown in Figure 7.3.

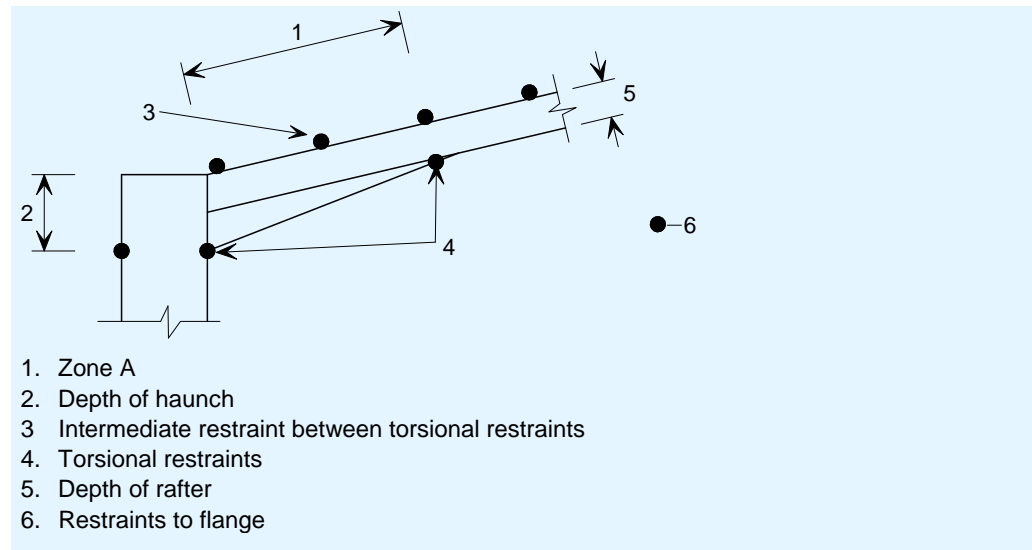

Figure 7.3 Restraints in the haunched region of a portal frame

It is necessary to check that the distance between torsional restraints (in Figure 7.2 this is indicated as ‘1’ in zone A) on both sides of a plastic hinge does not exceed L_s as given in § BB.3.2.2. In zone A, the member is tapered, and the bending moment is not constant.

L_s is given in § BB.3.2.2 Expression BB.11 for a three flange haunch and Expression BB.12 for a two-flange haunch. In both cases, a factor C_n (given in BB.3.3.2) takes account of non-linear moment gradients by calculating relevant parameters at the five cross-sections, as shown in Figure 7.4. The parameter c is a taper factor, given in § BB.3.3.3(1)B. § BB.3.2.2 also demands that the spacing of intermediate lateral restraints satisfies the requirements for L_m given in § BB.3.2.1. In Figure 7.2, both lengths indicated ‘2’ must satisfy this check.

Expression BB.9 is used for a three flanged haunch and BB.10 for a two-flanged haunch. A three flanged haunch would be the common situation when the haunch is fabricated from a section cutting and welded to the underside of the rafter.

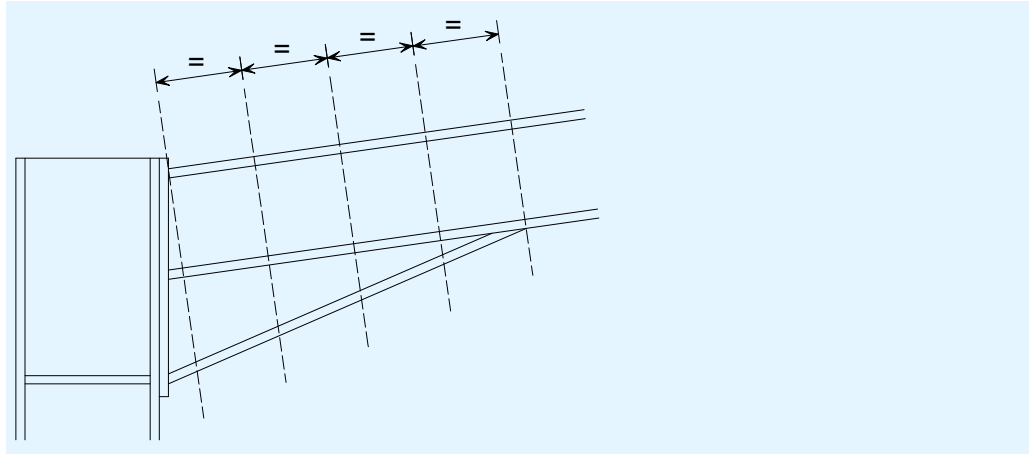

Figure 7.4 Cross-sections to be considered when determining C_n

Rafter stability in Zone B

Zone B generally extends from the ‘sharp’ end of the haunch to beyond the point of contraflexure (see Figure 7.2). The bottom flange is partially or wholly in compression over this length. Depending on the overall analysis, this zone may or may not contain a plastic hinge at the ‘sharp’ end of the haunch.

In this zone, torsional and lateral restraint will be provided at the ‘sharp’ end of the haunch. At the upper end, restraint will be provided by a purlin beyond the point of contraflexure. Some national authorities allow the point of contraflexure to be considered as a restraint, provided the following conditions below are satisfied.

- The rafter is a rolled section
- At least two bolts are provided in the purlin-to-rafter connections
- The depth of the purlin is not less than 0,25 times the depth of the rafter.

If a plastic hinge is predicted at the ‘sharp’ end of the haunch, a torsional restraint must be provided within a limiting distance in accordance with BB.3.1.2. The limiting distance may be calculated assuming:

- A constant moment – use Expression BB.6
- A linear moment gradient – use Expression BB.7
- A non-linear moment gradient – use Expression BB.8.

In addition, the spacing between the intermediate lateral restraints (indicated as ‘3’ in Figure 7.2) must satisfy the requirements for L_m as given in § BB.3.1.1.

If there is no plastic hinge, and in elastic regions, the member must be verified in accordance with Expressions 6.61 and 6.62 (see Section 6.2 of this document).

Rafter stability in Zone C

In Zone C, the purlins can be assumed to provide lateral restraint to the top (compression) flange provided they are tied into some overall restraint system. In many countries, it is simply assumed that the diaphragm action of the roof sheeting is sufficient to carry restraint forces to the bracing system; in other

countries any purlins providing restraint must be connected directly to the bracing system.

The out-of-plane checks require the verification of the member in accordance with Expressions 6.61 and 6.62 (see Section 6.2 of this document). Normally, if the purlins are regularly spaced, it is sufficient to check the rafter between restraints assuming the maximum bending moment and maximum axial load.

If a plastic hinge is predicted to form adjacent to the apex, it must be restrained. In addition, the usual requirements for stability near a plastic hinge must be satisfied:

- The distance between the restraint at the plastic hinge and the next lateral restraint must not exceed the limiting distance L_m .
- The distance to the next torsional restraint each side of the hinge must not exceed the limiting distance L_k , or L_s , with the spacing of intermediate restraints satisfying the requirements for L_m , all as described for zone B.

Even if there is no plastic hinge adjacent to the apex, it is normal practice to provide a torsional restraint at this point, as this will be necessary when considering the uplift combinations of actions – the bottom flange will be in compression.

7.3.2 Rafter and haunch stability for uplift conditions

Under uplift, most of the bottom flange of the rafter is in compression. A typical reversal bending moment diagram is shown in Figure 7.5.

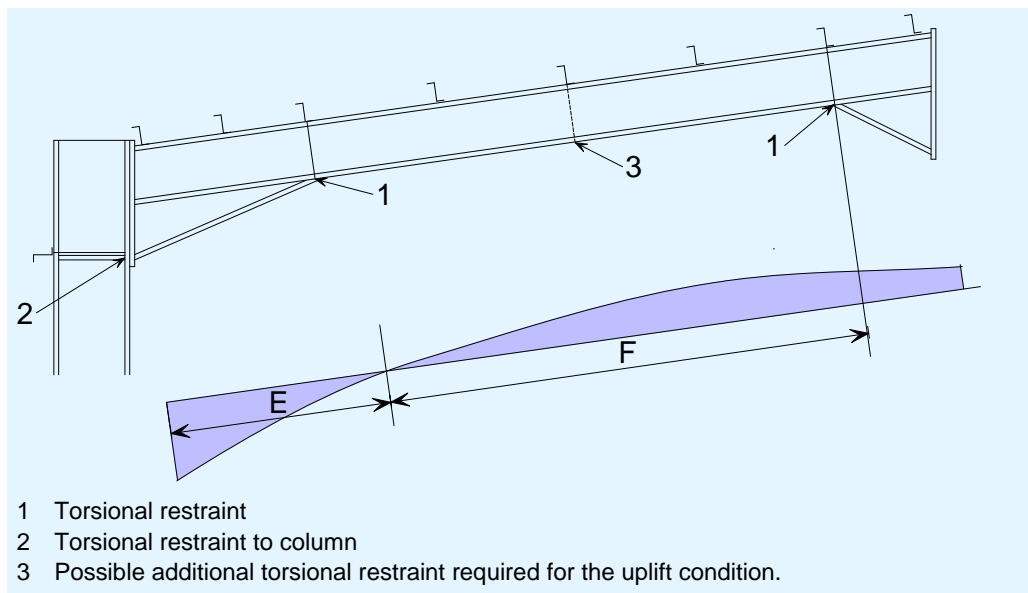

Figure 7.5 Typical purlin and rafter stay arrangement for wind uplift

This type of bending moment diagram will generally occur under internal pressure and wind uplift. Normally, the bending moments are smaller than the gravity load combinations and the members will remain elastic. The stability checks recommended below assume that plastic hinges will not occur in this uplift condition.

Haunch stability in Zone E

In Zone E, (see Figure 7.5) the top flange of the haunch will be in compression and will be restrained by the purlins.

The moments and axial forces are smaller than those in the gravity load combination. The members should be verified using Expression 6.62 (see Section 6.2 of this document). By inspection, it should be clear that the rafter in this zone will be satisfactory.

Stability in Zone F

In Zone F, the purlins will not restrain the bottom flange, which is in compression.

The rafter must be verified between torsional restraints. A torsional restraint will generally be provided adjacent to the apex, as shown in Figure 7.5. The rafter may be stable between this point and the virtual restraint at the point of contraflexure. If the rafter is not stable over this length, additional torsional restraints may be introduced, and each length of the rafter verified.

This verification may be carried out using Expression 6.62.

The beneficial effects of the restraints to the tension flange (the top flange, in this combination) may be accounted for using a modification factor C_m , taken from § BB.3.3.1(1)B for linear moment gradients and from § BB.3.3.2(1)B for non-linear moment gradients. If this benefit is utilised, the spacing of the intermediate restraints should also satisfy the requirements for L_m , found in § BB.3.1.1.

7.4 In-plane stability

In addition to the out-of-plane checks described in Section 7.3, in-plane checks must be satisfied using Expression 6.61.

For the in-plane checks, the axial resistance $\frac{\chi_y N_{Ed}}{\gamma_{M1}}$ is based on the system length of the rafter. The buckling resistance $\chi_{LT} \frac{M_{y,Rk}}{\gamma_{M1}}$ should be taken as the least resistance from any of the zones described in Section 7.3.

7.5 Design summary

- Rafters should be IPE or similar sections with Class 1 or Class 2 proportions under combined moment and axial load. Sections containing plastic hinges must be Class 1.
- Cross-sections should be checked to Section 6 of EN 1993-1-1.
- Detailed checks must be carried out to ensure adequate out-of-plane stability under both gravity and uplift conditions – see Sections 7.3.1 and 7.3.2.
- In-plane stability of the rafters and interaction with out-of-plane stability must be verified, using Expressions 6.61 and 6.62 – see Section 6.2.

8 COLUMN DESIGN

8.1 Introduction

As shown in Figure 8.1, the most highly loaded region of the rafter is reinforced by the haunch. By contrast, the column is subject to a similar bending moment at the underside of the haunch. The column will therefore need to be a significantly larger section than the rafter – typically proportioned to be 150% of the rafter size.

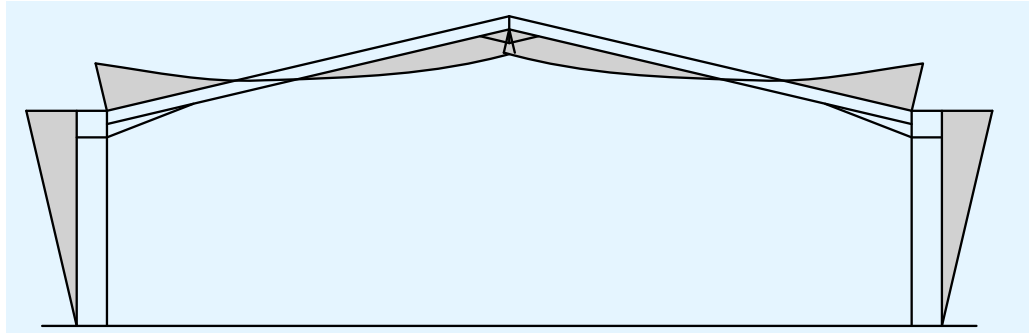

Figure 8.1 Typical bending moment diagram for frame with pinned base columns subject to gravity loading

The optimum design for most columns is usually achieved by the use of:

- A cross-section with a high ratio of I_{yy} to I_{zz} that complies with Class 1 or Class 2 under combined major axis bending and axial compression
- A plastic section modulus that is approximately 50% greater than that of the rafter.

The column size will generally be determined at the preliminary design stage on the basis of the required bending and compression resistances.

8.2 Web resistance

The column web is subject to high compression at the level of the bottom flange of the haunch. In addition, EN 1993-1-1 § 5.6(2) requires that web stiffeners are provided at plastic hinge locations, if the applied transverse force exceeds 10% of the member's shear resistance. For these reasons, full depth stiffeners are usually required to strengthen the web.

8.3 Column stability

8.3.1 Column stability under maximum gravity combinations

Whether the frame is designed plastically or elastically, a torsional restraint should always be provided at the underside of the haunch. Additional torsional restraints may be required within the length of the column because the side rails are attached to the (outer) tension flange rather than to the compression flange. As noted in Section 6.3, a side rail that is not continuous (for example, interrupted by industrial doors) cannot be relied upon to provide adequate

restraint. The column section may need to be increased if intermediate restraints cannot be provided.

Restraint may be provided by stays to the inside flange, as shown in Figure 8.2 shows stiffeners in the column, which are only typical at the level of the underside of the haunch where they act as compression stiffeners. At other locations, stiffeners are generally not required.

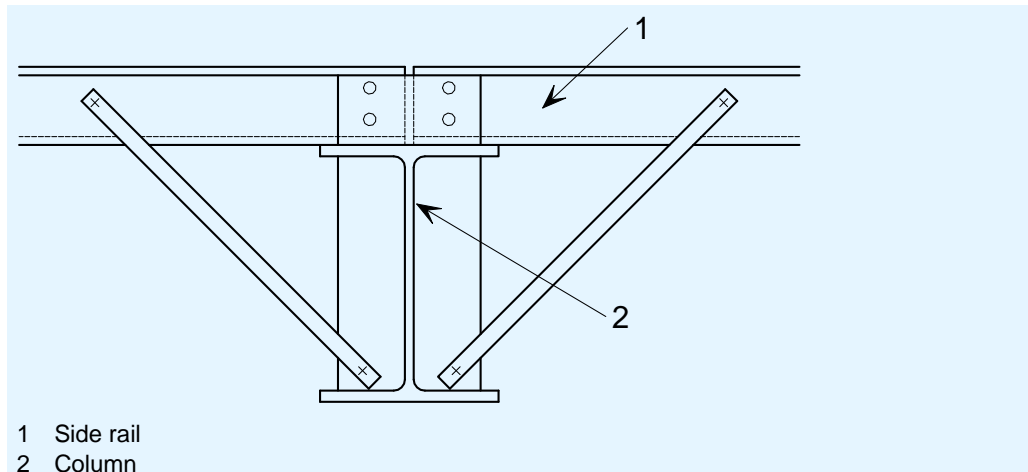

Figure 8.2 Typical eaves detail using a column stay

At the underside of the haunch level, it may be convenient to provide a hot-rolled member, typically a hollow section, to provide restraint. It is essential to connect the bracing on the inner flange to the outer flange at some point in the length of the building.

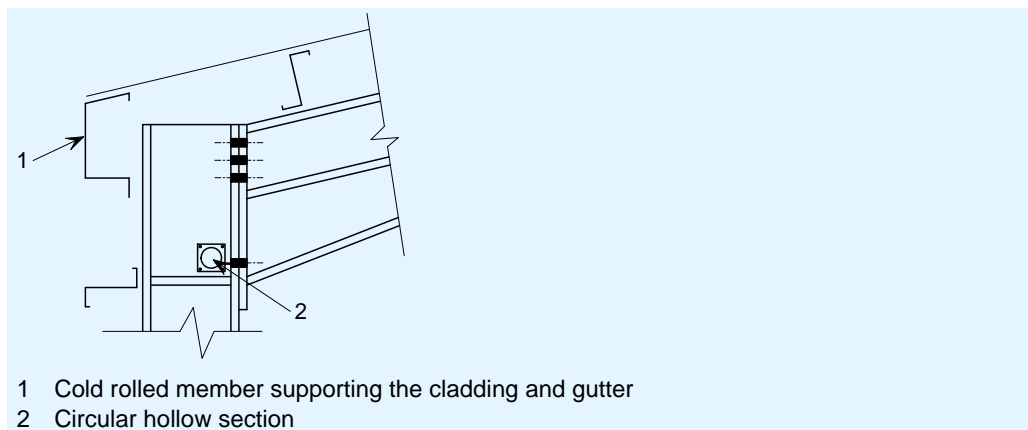

Figure 8.3 Typical eaves detail using a circular hollow section as a longitudinal bracing member

Figure 8.4 shows a typical moment distribution for permanent and variable actions and indicates the positions of restraints on a typical column. The presence of a plastic hinge will depend on loading, geometry and choice of column and rafter sections. In a similar way to the rafter, both out-of-plane and in-plane stability must be verified.

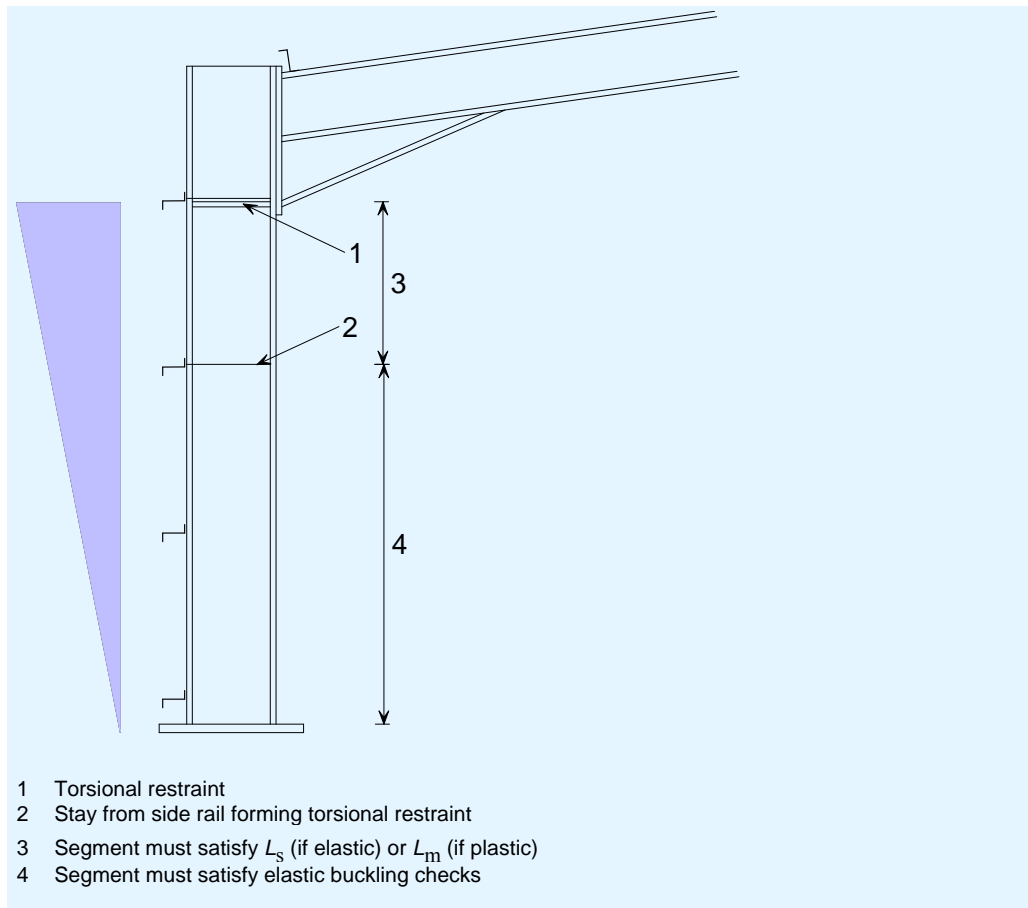

Figure 8.4 Typical portal frame column with plastic hinge at underside of haunch

8.3.2 Out-of-plane stability under gravity combinations

If there is a plastic hinge at the underside of the haunch, the distance to the adjacent torsional restraint must be less than the limiting distance L_s as given by EN 1993-1-1 § BB.3.1.2. Expression BB.7 should be used when the moment is linear, and BB.8 when the moment is not linear.

In addition, the spacing between intermediate lateral restraints should satisfy the requirements for L_m as given in BB.3.1.1.

If the stability between torsional restraints cannot be verified, it may be necessary to introduce additional torsional restraints. In Figure 8.4, the check between the torsional restraint (indicated as '1' in the figure) and the base was not satisfied – an additional torsional restraint was introduced at location '2'. If it is not possible to provide additional intermediate restraints, the size of the member must be increased.

In all cases, a lateral restraint must be provided within L_m of a plastic hinge.

If there is no plastic hinge, the stability of the column should be checked in accordance with Expression 6.62 (See Section 6.2 of this document) Account may be taken of the benefits of tension flange restraint as described in Appendix C of this document.

8.3.3 Stability under uplift combinations

When the frame is subject to uplift, the column moment will reverse. The bending moments will generally be significantly smaller than those under gravity loading combinations, and the column will remain elastic.

Out-of-plane checks should be undertaken in accordance with Expression 6.62 (See Section 6.2 of this document).

8.4 In-plane stability

In addition to the out-of-plane checks described in Section 8.3, in-plane checks must be satisfied using Expression 6.61.

For the in-plane checks, the axial resistance $\frac{\chi_y N_{Ed}}{\gamma_{M1}}$ is based on the system length of the column. The buckling resistance $\chi_{LT} \frac{M_{y,Rk}}{\gamma_{M1}}$ should be taken as the least resistance from any of the zones described in Section 8.3.

8.5 Design summary

- Columns should be IPE or similar sections with Class 1 or Class 2 proportions under combined moment and axial load.
- The section should ideally be able to resist the high shears within the depth of the eaves connection, without shear stiffening.
- Critical cross-sections should be checked to Section 6 of EN 1993-1-1.
- Detailed stability checks, as defined in Sections 8.3 and 8.4 must be carried out to ensure adequate stability.

9 BRACING

9.1 General

Bracing is required to resist longitudinal actions, principally wind actions and provide restraint to members. The bracing must be correctly positioned and have adequate strength and stiffness to justify the assumptions made in the analysis and member checks.

9.2 Vertical bracing

9.2.1 General

The primary functions of vertical bracing in the side walls of the frame are:

- To transmit the horizontal loads to the ground. The horizontal forces include forces from wind and cranes.
- To provide a rigid framework to which side rails may be attached so that they can in turn provide stability to the columns.
- To provide temporary stability during erection.

According to EN 1993-1-1, the bracing will have to satisfy the requirement of § 5.3.1, 5.3.2 and 5.3.3 for global analysis and imperfections within the bracing system.

The bracing system will usually take the form of:

- A single diagonal hollow section
- Hollow sections in a K pattern
- Crossed flats (usually within a cavity wall), considered to act in tension only
- Crossed angles.

The bracing may be located:

- At one or both ends of the building, depending on the length of the structure
- At the centre of the building (See Section 9.2.5)
- In each portion between expansion joints (where these occur).

Where the side wall bracing is not in the same bay as the plan bracing in the roof, an eaves strut is required to transmit the forces from the roof bracing into the wall bracing.

9.2.2 Bracing using circular hollow sections

Hollow sections are very efficient in compression, which eliminates the need for cross bracing. Where the height to eaves is approximately equal to the spacing of the frames, a single bracing member at each location is economic (Figure 9.1). Where the eaves height is large in relation to the frame spacing, a K brace is often used (Figure 9.2).

An eaves strut may be required in the end bays, depending on the configuration of the plan bracing (see Section 9.3.2).

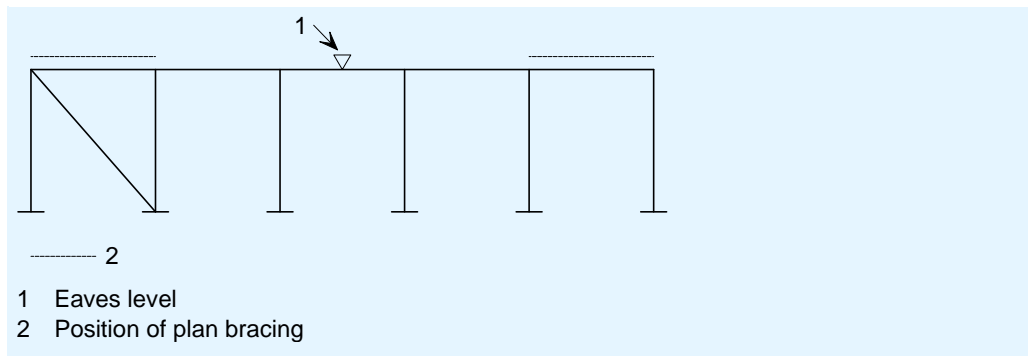

Figure 9.1 Single diagonal bracing for low rise frames

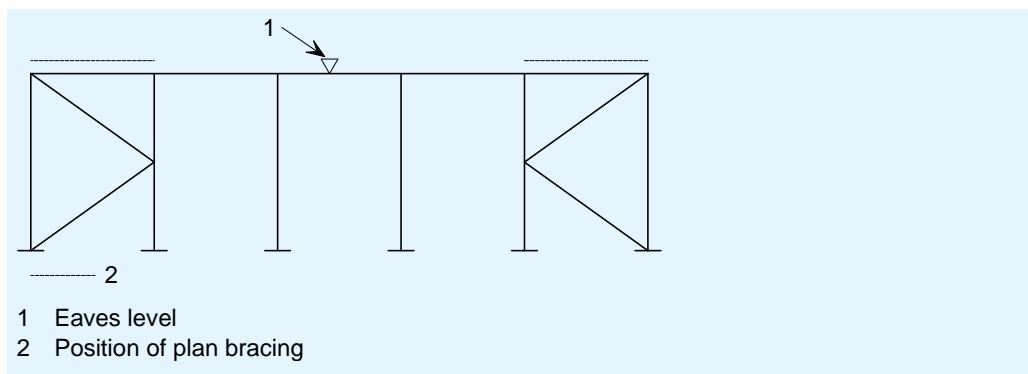

Figure 9.2 K bracing arrangement for taller frames

9.2.3 Bracing using angle sections or flats

Cross braced angles or flats (within a masonry cavity wall) may be used as bracing (as shown in Figure 9.3). In this case, it is assumed that only the diagonal members in tension are effective.

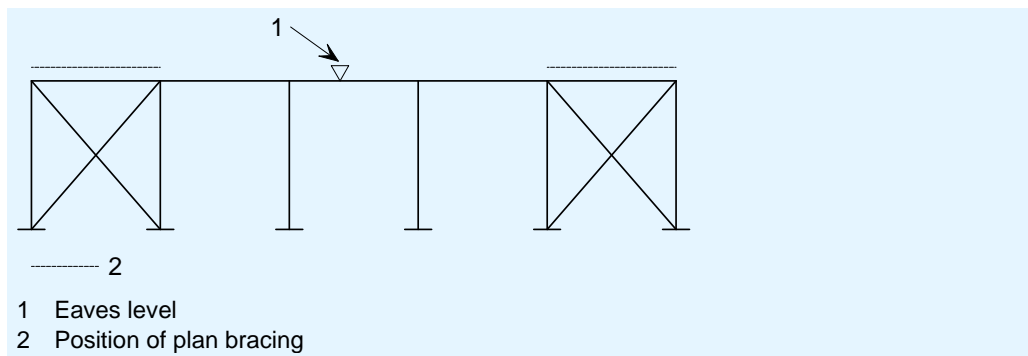

Figure 9.3 Typical cross bracing system using angles or flats as tension members

9.2.4 Bracing in a single bay

For vertical bracing provided in a single bay, an eaves strut is required to transmit wind forces from the roof bracing into the vertical bracing (Figure 9.4). Further details of eaves struts are given in Section 12.2.

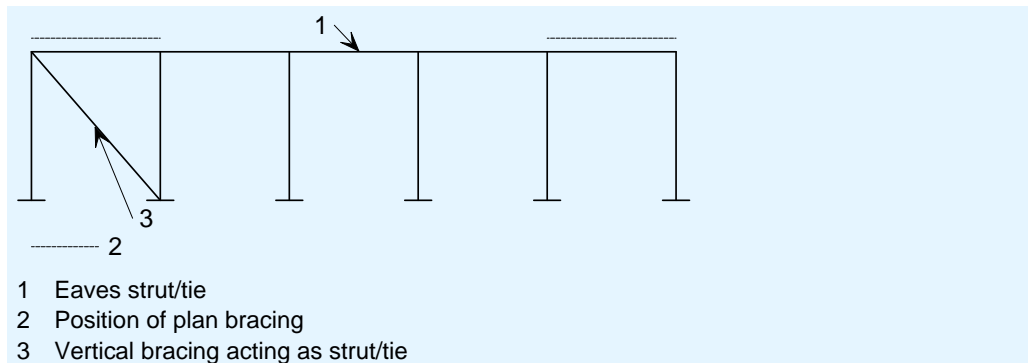

Figure 9.4 Bracing in a single end bay with an eaves strut

9.2.5 Single central braced bay

The concept of providing a single braced bay near the centre of a structure (Figure 9.5) is unpopular because of the need to start erection from a braced bay and to work down the full length of a building from that point. However, bracing in the middle of the building has the advantage that it allows free thermal expansion of the structure, which is particularly valuable in locations such as Southern Europe and the Middle East where the diurnal temperature range is very large. In most of Europe, the expected temperature range is more modest, typically -5°C to $+35^{\circ}\text{C}$, and overall expansion is not generally considered to be a problem. If a central braced bay is used, it may be necessary to provide additional temporary bracing in the end bays to assist in erection.

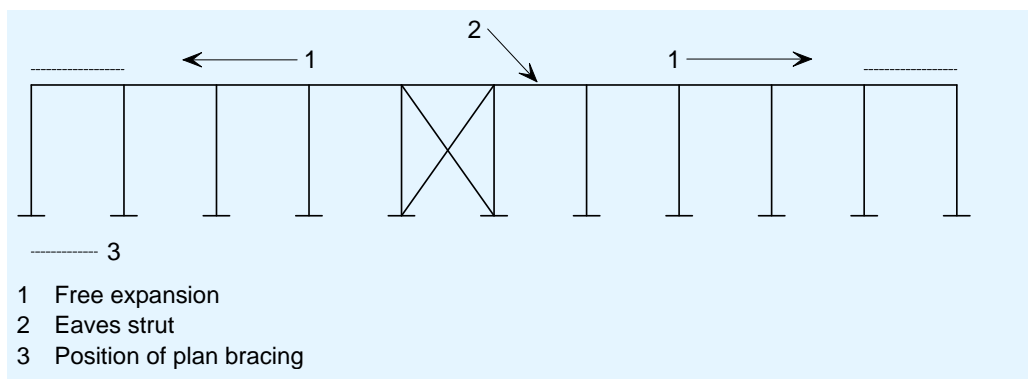

Figure 9.5 Typical cross bracing at centre of the structure to allow free thermal expansion

9.2.6 Bracing using moment-resisting frames

Where it is difficult or impossible to brace the frame vertically by conventional bracing, it is necessary to introduce moment-resisting frames in the elevations. There are two basic possibilities:

- A moment-resisting frame in one or more bays, as shown in Figure 9.6.
- Use of the complete elevation to resist longitudinal forces, with moment resisting connection often located in the end bays, where the end column is turned through 90° to provide increased stiffness in the longitudinal direction, as shown in Figure 9.7. This arrangement is only possible if the end frame (the gable) is constructed from a beam and column arrangement, rather than a portal frame. Gable frames are discussed in Section 10.

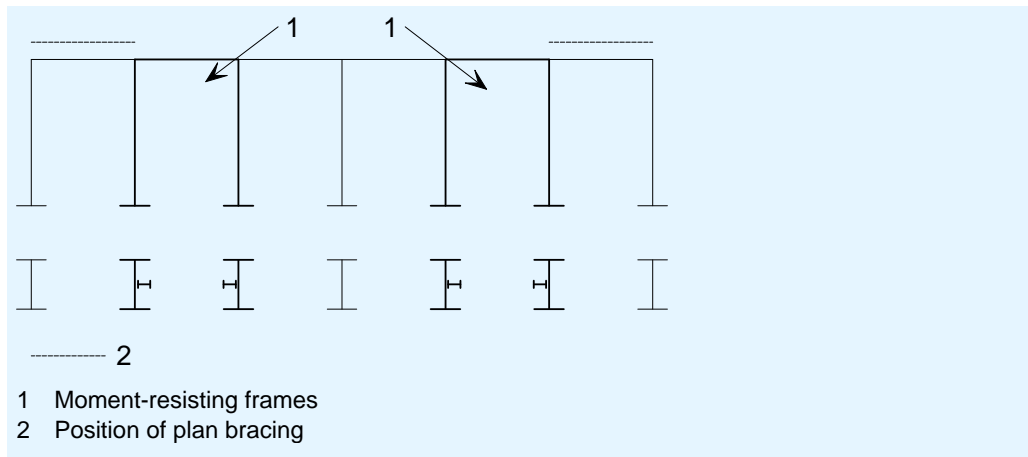

Figure 9.6 Individual, local sway frames

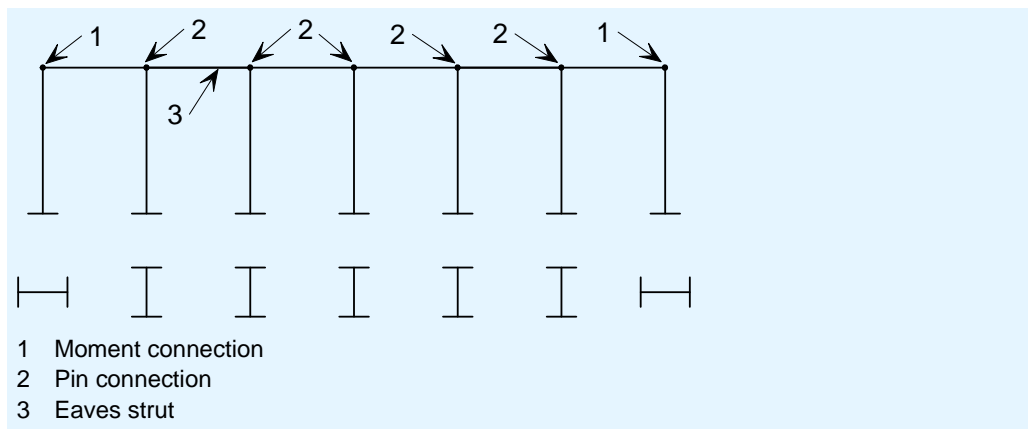

Figure 9.7 Hybrid frame along the full length of the building

In design of both systems, it is suggested that:

- The bending resistance of the portalised bay (not the main portal frame) is checked using an elastic frame analysis
- Deflection under the equivalent horizontal forces is restricted to $h/1000$.
- The stiffness is assured by restricting serviceability deflections to a maximum of $h/360$, where h is the height of the portalised bay.

In some cases, it is possible to provide conventional bracing on one elevation, and provide moment resisting frames on the other. The effects of racking action due to the difference in stiffness of the sides is generally negligible due to the diaphragm action of the roof.

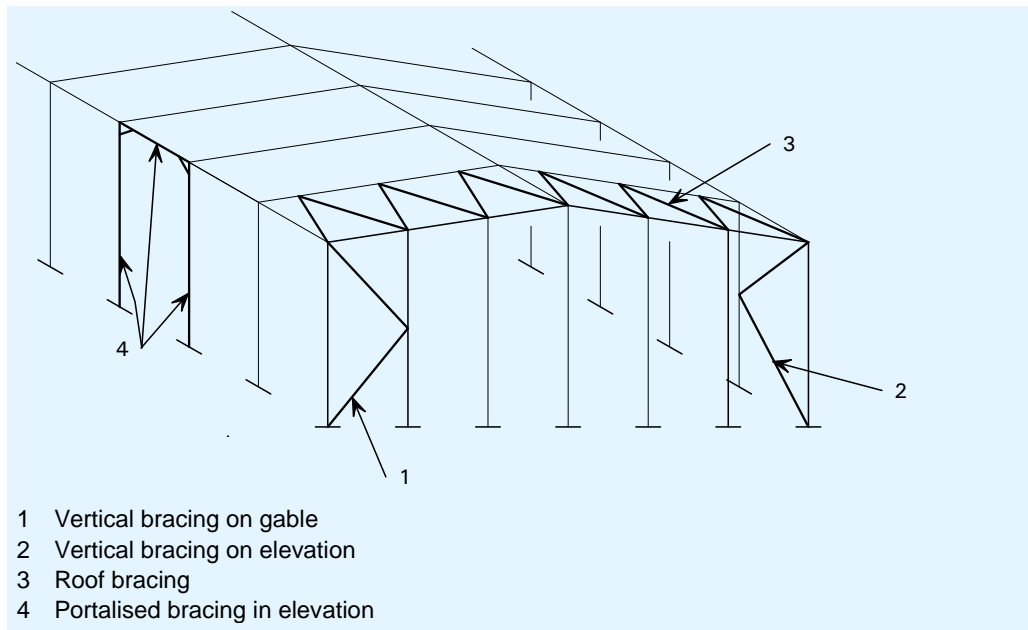

Figure 9.8 Portalising an opening on one side with conventional bracing on the other side of the structure

9.2.7 Bracing to restrain columns

If side rails and column stays provide lateral or torsional restraint to the column, it is important to identify the route of the restraint force to the vertical bracing system. If there is more than one opening in the side of the building, additional intermediate bracing may be required. This bracing should be provided as close to the plane of the side rail as possible, preferably on the inside face of the outer flange (Figure 9.9).

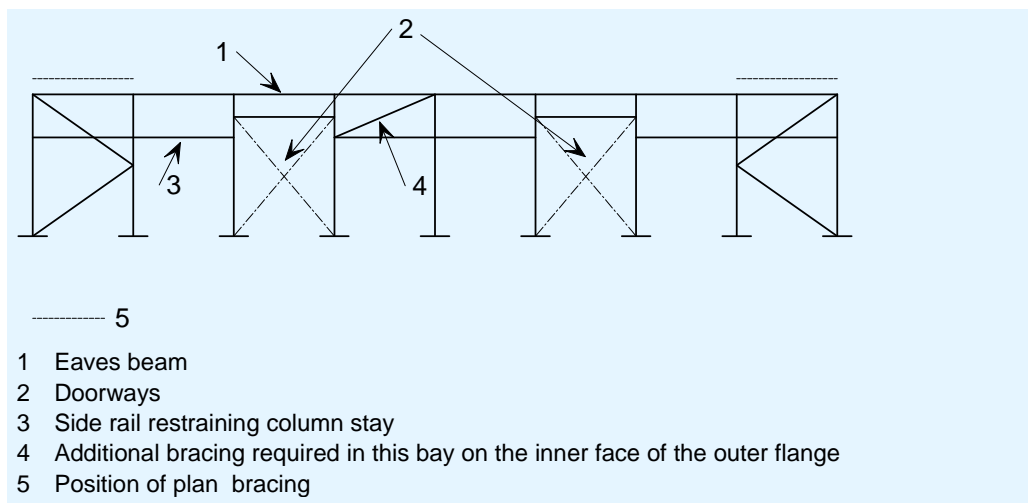

Figure 9.9 Typical bracing pattern in side of building with openings

It is not normally necessary for the side rail that provides restraint at column stay positions to be aligned with a node of the vertical bracing system. It can be assumed that diaphragm action in the vertical sheeting and the transverse stiffness of the column can transmit the load into the vertical bracing system.

Where a member is used to restrain the position of a plastic hinge in the column, it is essential that it is tied properly into the bracing system. This can result in the configuration shown in Figure 9.10. Where there is more than one

opening in the side of the building, additional intermediate bracing will be required in a similar way to that described above.

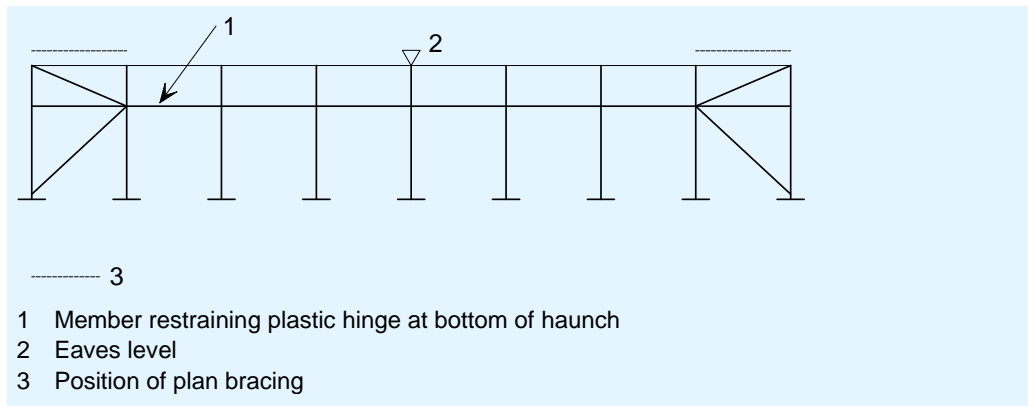

Figure 9.10 Typical bracing pattern in building using a hot-rolled member to restrain a plastic hinge at the base of the haunch

9.2.8 Bracing to restrain longitudinal loads from cranes

If a crane is directly supported by the frame, the longitudinal surge force will be eccentric to the column, and will tend to cause the column to twist, unless additional restraint is provided. A horizontal truss at the level of the girder top flange or, for lighter cranes, a horizontal member on the inside face of the column flange tied into the vertical bracing may be adequate to provide the necessary restraint.

For large horizontal forces, additional bracing should be provided in the plane of the crane girder (Figure 9.11 and Figure 9.12). The criteria given in Table 9.1 were given by Fisher^[3] to define the bracing requirements.

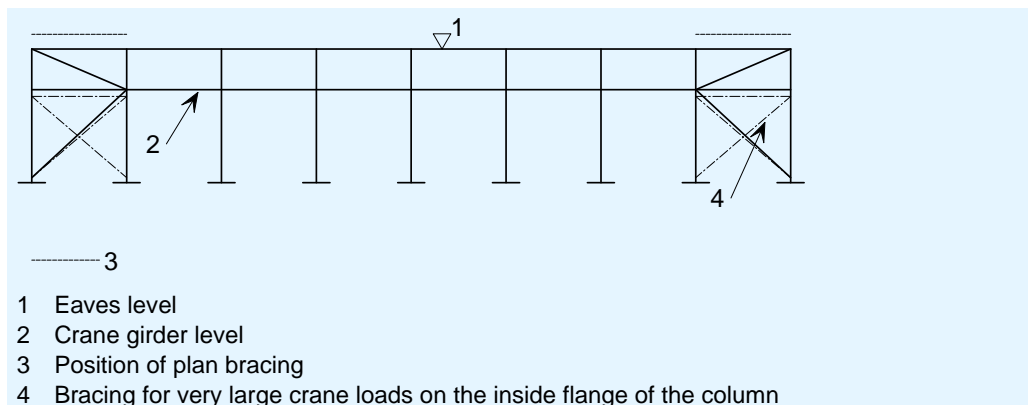

Figure 9.11 Elevation showing position of additional bracing in the plane of the crane girder

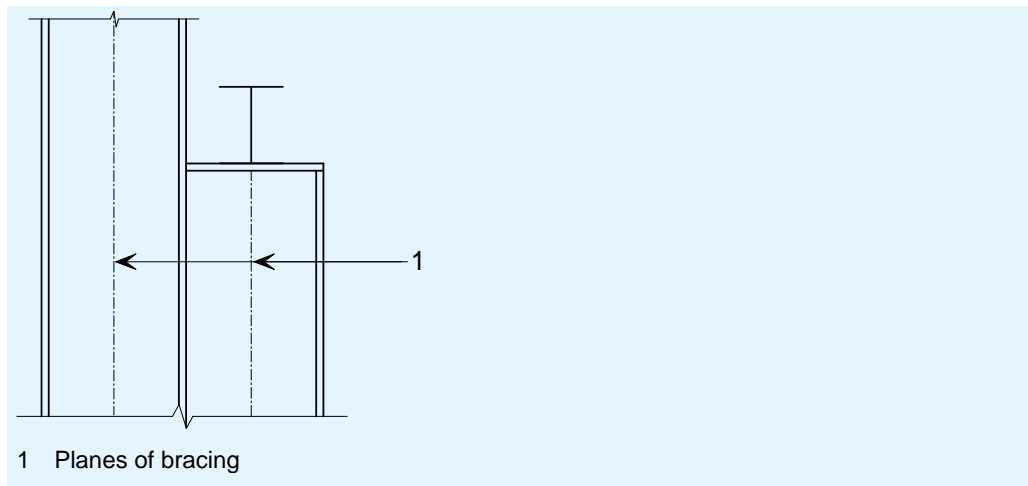

Figure 9.12 Detail showing additional bracing in the plane of the crane girder

Table 9.1 Bracing requirements for crane girders

Factored longitudinal force	Bracing requirement
Small (<15 kN)	Use wind bracing
Medium (15 - 30 kN)	Use horizontal bracing to transfer force from the crane to plane of bracing
Large (> 30 kN)	Provide additional bracing in the plane of the longitudinal crane forces

9.3 Plan bracing

9.3.1 General

Plan bracing is placed in the horizontal plane, or in the plane of the roof. The primary functions of the plan bracing are:

- To transmit horizontal wind forces from the gable posts to the vertical bracing in the walls
- To transmit any drag forces from wind on the roof to the vertical bracing
- To provide stability during erection
- To provide a stiff anchorage for the purlins which are used to restrain the rafters.

In order to transmit the wind forces efficiently, the plan bracing should connect to the top of the gable posts.

According to EN 1993-1-1, the bracing will have to satisfy the requirement of § 5.3.1, 5.3.2 and 5.3.3 for global analysis and imperfections within the bracing system.

9.3.2 Bracing using circular hollow sections

In modern construction, circular hollow section bracing members are generally used in the roof and are designed to resist both tension and compression. Many arrangements are possible, depending on the spacing of the frames and the positions of the gable posts. Two typical arrangements are shown in

Figure 9.13 and Figure 9.14. The bracing is usually attached to cleats on the web of the rafter, as shown in Figure 9.15. The attachment points should be as close to the top flange as possible, allowing for the size of the member and the connection.

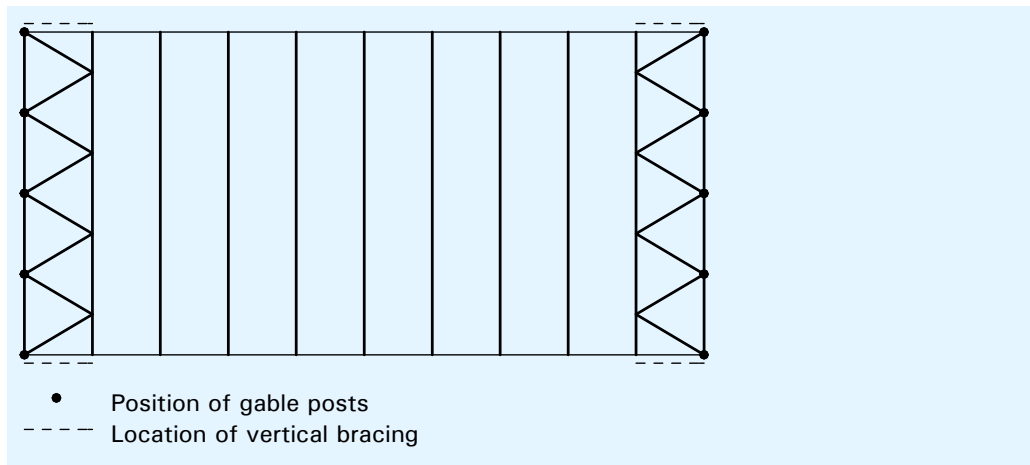

Figure 9.13 Plan view showing both end bays braced

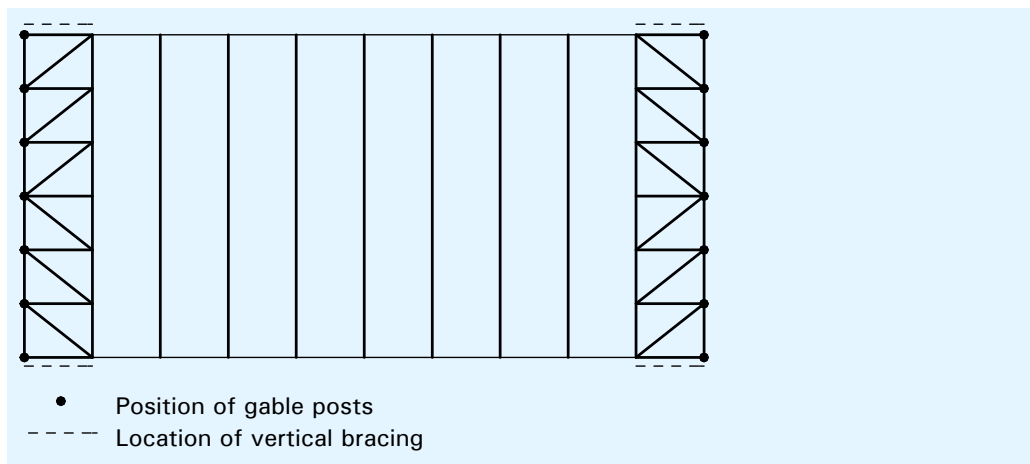

Figure 9.14 Plan view showing both end bays braced where the gable posts are closely spaced

An eaves strut may be required in the end bays, depending on the configuration of the plan bracing. In all cases, it is good practice to provide an eaves tie along the length of the building.

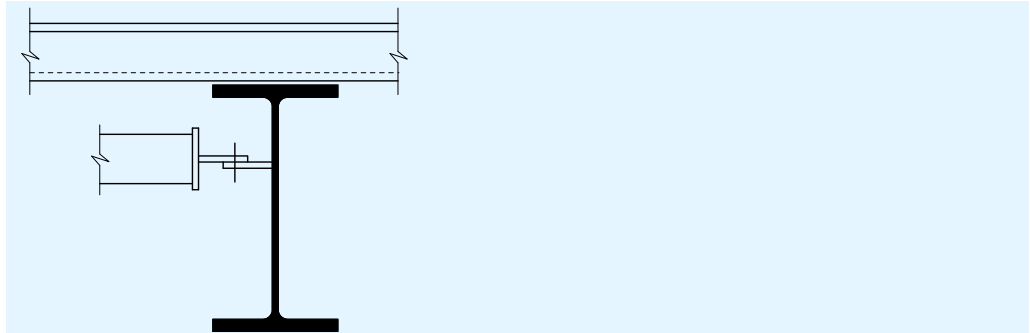

Figure 9.15 Typical connection detail for circular hollow section bracing

9.3.3 Bracing using angle sections

The use of angles is not common in modern structures, but cross-braced angles have an advantage in that the diagonal members are relatively small because they may be designed to resist tension only (Figure 9.16).

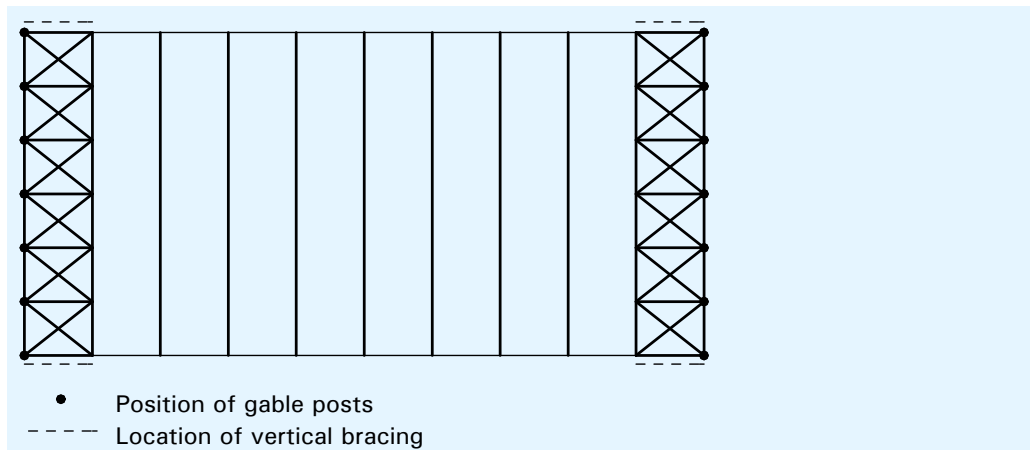

Figure 9.16 Plan view showing both end bays braced using crossed angle sections

9.4 Restraint to inner flanges

Restraint to the inner flanges of rafters or columns is often most conveniently formed by diagonal struts from the purlins or sheeting rails to small plates welded to the inner flange and web. Pressed steel ties are commonly used. As the ties act in tension only, angles must be substituted in locations where the restraint must be provided on one side only.

The effectiveness of such restraint depends on the stiffness of the system, especially the stiffness of the purlins. The effect of purlin flexibility on the bracing is shown in Figure 9.17. Where the proportions of the members, purlins and spacings differ from proven previous practice, the effectiveness should be checked. This can be done using the formula given in Section 9.5, or other methods, such as may be found in bridge codes for U-frame action.

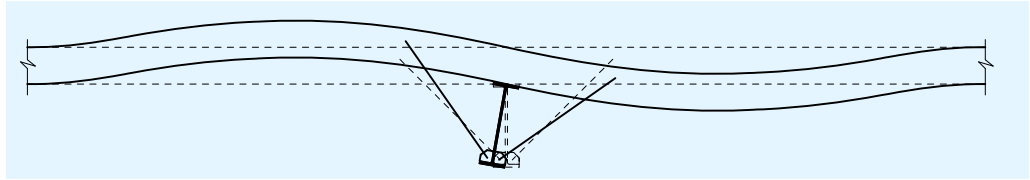

Figure 9.17 Effect of purlin flexibility on bracing

9.5 Bracing at plastic hinges

Section 6.3.5.2 of EN 1993-1-1 recommends that bracing should be provided to both tension and compression flanges at or within $0,5h$ of the calculated plastic hinges, where h is the depth of the member (see Figure 9.18).

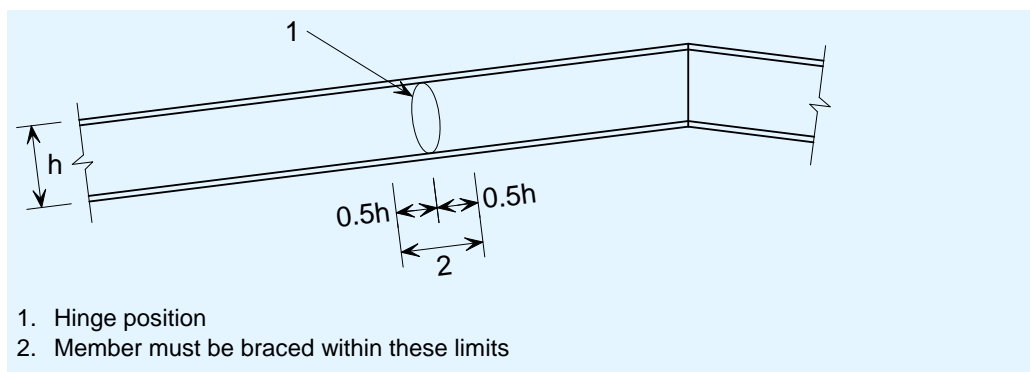

Figure 9.18 Bracing at plastic hinges

EN 1993-1-1 recommends that the bracing to a plastic hinge should be designed assuming that the compression flange exerts a lateral load of 2,5% of the flange force, (taken as the plastic moment resistance/depth of section) perpendicular to the web of the member.

In addition, according to § 6.3.5.2(5)B of EN 1993-1-1, the bracing system must be able to resist the effects of local forces Q_m applied at each stabilised member at the plastic hinge locations, where:

$$Q_m = 1,5 \alpha_m \frac{N_{f,Ed}}{100}$$

where:

$N_{f,Ed}$ is the axial force in the compressed flange of the stabilised member at the plastic hinge location

α_m is a coefficient to recognise the statistical benefits of restraining a group of members compared with an individual member

$$\alpha_m = \sqrt{0,5 \left(1 + \frac{1}{m} \right)}$$

in which m is the number of members to be restrained.

Where the plastic hinge is braced by diagonals from the purlins (see Figure 6.3), the stiffness of the ‘U-frame’ formed by the purlin and diagonals is especially important. Where the proportions of the members, purlins or spacings differ from previous practice, the effectiveness should be checked. In

the absence of other methods, the stiffness check may be based on the work of Horne and Ajmani^[4]. Thus, the support member (the purlin or sheeting rail) should have $I_{y,s}$ such that:

$$\frac{I_{y,s}}{I_{y,f}} \geq \frac{f_y}{190 \times 10^3} \frac{L(L_1 + L_2)}{L_1 L_2}$$

where:

f_y is the yield strength of the frame member

$I_{y,s}$ is the second moment of area of the supporting member (purlin or sheeting rail) about the axis parallel to the longitudinal axis of the frame member (i.e. the purlin major axis in normal practice)

$I_{y,f}$ is the second moment of area of the frame member about the major axis

L is the span of the purlin or sheeting rail

L_1 and L_2 are the distances either side of the plastic hinge to the eaves (or valley) or points of contraflexure, whichever are the nearest to the hinge (see Figure 9.18).

Hinges that form, rotate then cease, or even unload and rotate in reverse, must be fully braced. However, hinges that occur in the collapse mechanism but rotate only above ULS need not be considered as plastic hinges for ULS checks. These hinges are easily identified by elastic-plastic or graphical analysis.

Analysis cannot account for all of the section tolerances, residual stresses and material tolerances. Care should be taken to restrain points where these effects could affect the hinge positions, e.g. the shallow end of the haunch instead of the top of the column. Wherever the bending moments come close to the plastic moment capacity, the possibility of a hinge should be considered.

9.6 Design summary

Bracing must be provided with adequate strength and stiffness to act in conjunction with the purlins, side rails and eaves beams to resist horizontal actions, including wind, to provide overall stability to the building and to provide local stability to the columns and rafters. Bracing must be provided:

- To side walls, in a vertical plane; see Section 9.2
- On plan at or near the roof of the building; see Section 9.3
- Stays are required to stabilise inner flanges of the columns and rafters where they are in compression and potentially unstable; see Section 9.4
- At, or near, plastic hinge positions to provide torsional restraint; see Section 9.5.

10 GABLES

10.1 Types of gable frame

Gable frames are typically of two forms:

- An identical portal frame to the remainder of the structure. The gable columns do not support the rafter. This form of gable is used for simplicity, or because there is the possibility of extending the structure in the future.
- A gable frame comprising gable posts and simply supported rafters. The gable posts support the rafters. Gable frames of this form require bracing in the plane of the gable, as shown in Figure 10.1. The advantage of this form of gable is that the rafters and external columns are smaller than those in a portal frame.

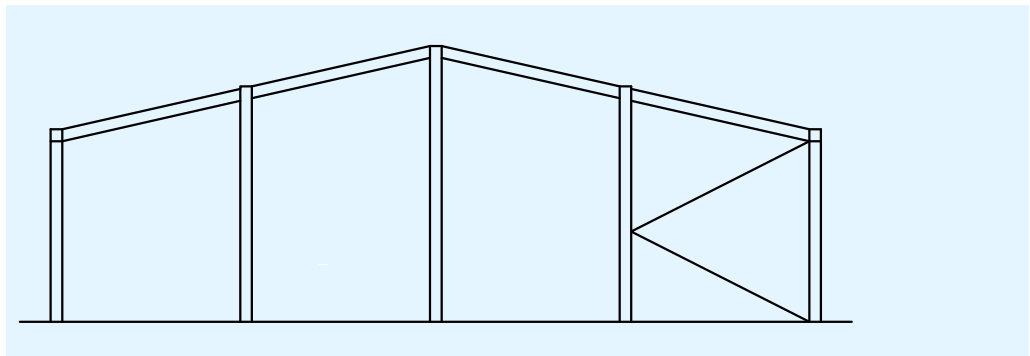

Figure 10.1 Gable frame from columns, beams and bracing

10.2 Gable columns

Gable columns are designed as vertical beams, spanning between the base and the rafter. At rafter level, the horizontal load from the gable column is transferred into the roof bracing, to the eaves, and then to the ground via the bracing in the elevations.

The gable column will be designed for pressure and suction. The maximum suction may be when the gable is on the downwind elevation, as shown in Figure 10.2(a), or more likely when the gable is parallel to the wind direction, as shown in Figure 10.2(b).

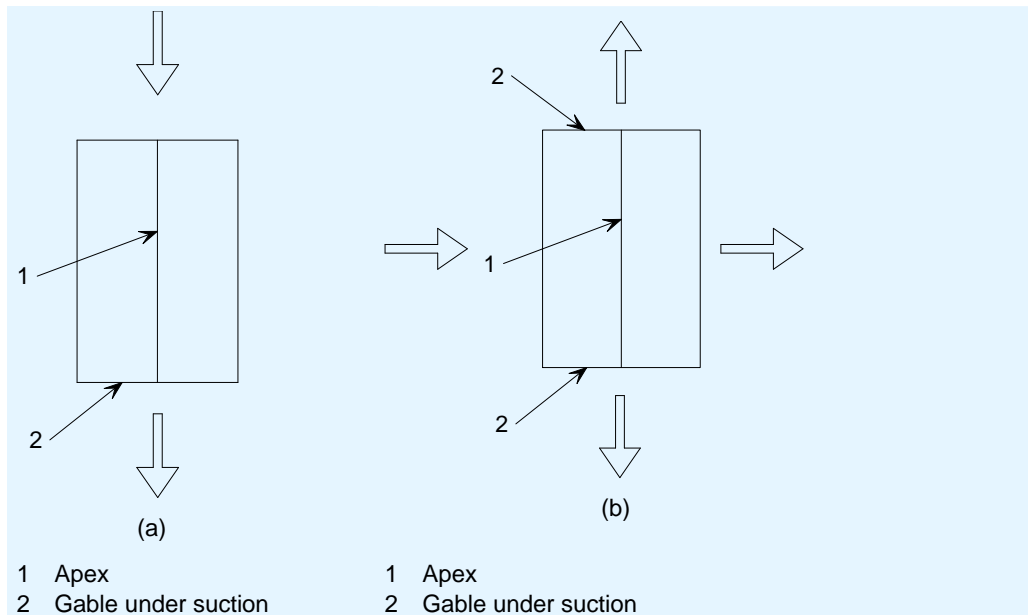

Figure 10.2 Wind loads on gables

The internal pressure or suction contributes to the net loads on the gable. When the net loads are equivalent to an external pressure, the outside flanges of the gable columns are in compression, but are restrained out-of-plane by the side rails. When the net loads are equivalent to an external suction, the inside flanges of the gable columns are in compression. This design case may be the most onerous of the two conditions. It may be possible to reduce the length of the unrestrained inside flange of the gable columns by introducing column stays from the side rails, as illustrated in Figure 6.3.

10.3 Gable rafters

If the gable is of the form shown in Figure 10.1, the gable rafters are generally simply supported I section members. In addition to carrying the vertical loads, the gable rafters often act as chord members in the roof bracing system and this design case must be verified.

If a portal frame is adopted as a gable frame, it is common to adopt an identical frame size, even though the vertical loads on the end frame are rather less. Generally, the reduced vertical loading will mean that the rafter can accommodate the axial force as part of the roof bracing system without needing to increase the section size.

11 CONNECTIONS

The major connections in a portal frame are the eaves and apex connections, which are both moment-resisting. The eaves connection in particular must generally carry a very large bending moment. Both the eaves and apex connections are likely to experience reversal in certain combinations of actions and this can be an important design case. For economy, connections should be arranged to minimise any requirement for additional reinforcement (commonly called stiffeners). This is generally achieved by:

- Making the haunch deeper (increasing the lever arms)
- Extending the connection above the top flange of the rafter (an additional bolt row)
- Adding bolt rows
- Selecting a stronger column section.

The design of moment resisting connections is covered in detail in *Single-storey Buildings. Part 11: Moment connections*^[5].

11.1 Eaves connections

A typical eaves connection is shown in Figure 11.1. In addition to increasing the moment resistance of the rafter, the presence of the haunch increases the lever arms of the bolts in the tension zone, which is important if the connection carries a large bending moment. Generally the bolts in the tension zone (the upper bolts under conventional gravity loading) are nominally allocated to carry tension from the applied moment, whilst the lower bolts (adjacent to the compression stiffener) are nominally allocated to carry the vertical shear, which is generally modest.

Because the portal frame members are chosen for bending resistance, deep members with relatively thin webs are common in portal frames. A compression stiffener in the column is usually required. The web panel of the column may also need reinforcing, either with a diagonal stiffener, or an additional web plate (referred to as a supplementary web plate)

The end plate and column may be extended above the top of the rafter, with an additional pair of bolts. The end plate on the rafter is unlikely to require stiffening as it can simply be made thicker, but it is common to find that the column flange requires strengthening locally to the tension bolts. Stiffeners are expensive, so good connection design would minimise the need for stiffeners by judicious choice of connection geometry.

Under a reversed bending moment, it may be necessary to provide a stiffener to the column web at the top of the column, aligned with the top flange of the rafter.

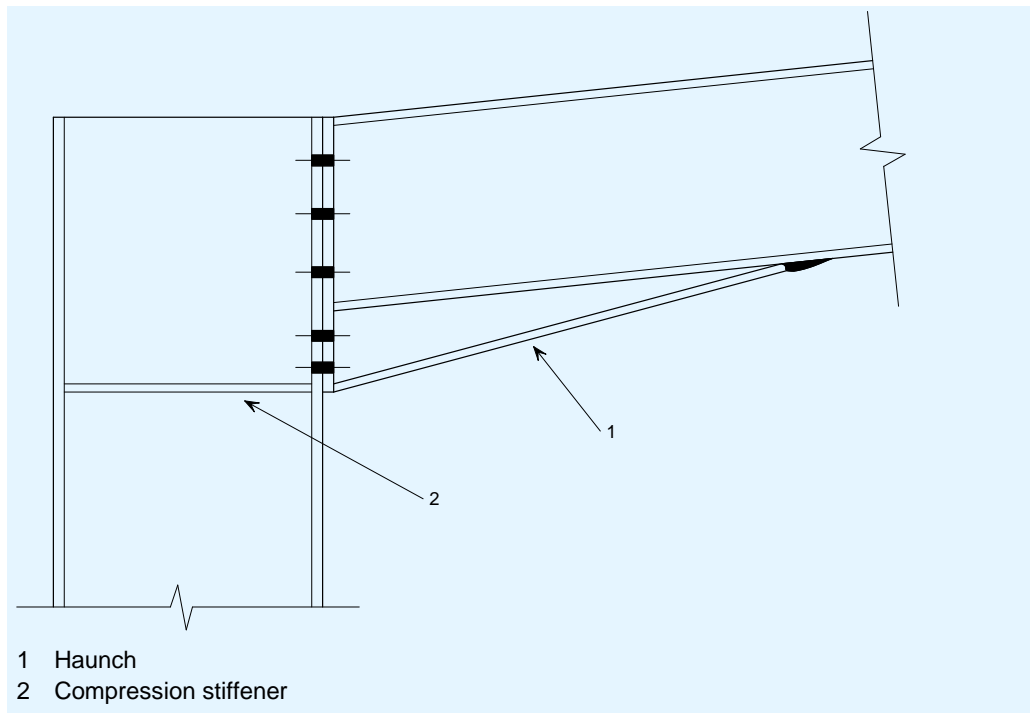

Figure 11.1 Typical eaves connection

11.2 Apex connections

A typical apex connection is shown in Figure 11.2. Under normal loading conditions the bottom of the connection is in tension. The haunch below the rafter, which in lightly loaded frames may be a simple extended end plate, serves to increase the lever arms to the tension bolts, thus increasing the moment resistance. The haunch is usually small and short, and is not accounted for in frame design.

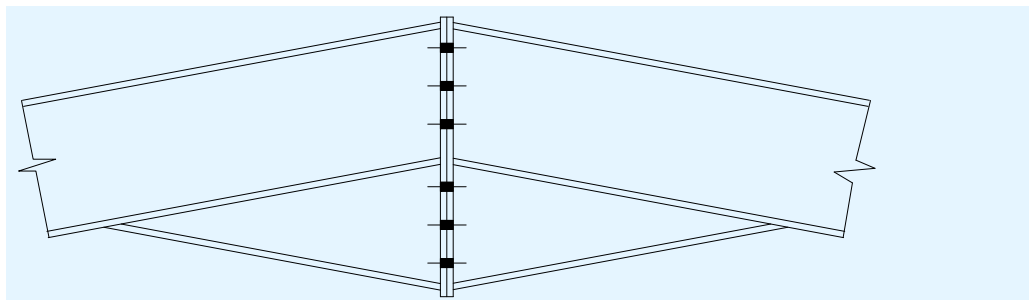

Figure 11.2 Typical apex

11.3 Bases, base plates and foundations

11.3.1 General

The following terminology for the components at the foundation is used in this document:

- Base - the combined arrangement of base plate, holding down bolts, and concrete foundation. The terms *nominally pinned* and *nominally rigid* are usually applied to the performance of the base, in relation to its stiffness.
- Base plate - the steel plate at the base of the column, connected to the column by fillet welds.
- Holding down bolts - bolts through the base plate that are anchored into the concrete foundation.
- Foundation - the concrete footing required to resist compression, uplift, and, where necessary, over-turning moments.
- Anchor plates - plates or angles used to anchor the holding down bolts into the foundation. They should be of such a size as to provide an adequate factor of safety against bearing failure of the concrete.

In the majority of cases, a nominally pinned base is provided, because of the difficulty and expense of providing a nominally rigid base which is moment resisting. Not only is the steel base connection significantly more expensive, the foundation must also resist the moment, which increases costs significantly.

Where crane girders are supported by the column, moment resisting bases may be required to reduce deflections to acceptable limits. Typical base plate/foundation details are shown in Figure 11.3 to Figure 11.5.

In a nominally pinned base for larger columns, the bolts can be located entirely within the column profile (Figure 11.3(a)). For smaller columns (less than approximately 400 mm), the base plate is made larger so that the bolts can be moved outside the flanges (Figure 11.3(b)).

A nominally rigid, moment resisting base is achieved by providing a bigger lever arm for the bolts and a stiffer base plate by increasing the plate thickness as shown in Figure 11.4. Additional gusset plates may be required for heavy moment connections, as illustrated in Figure 11.5.

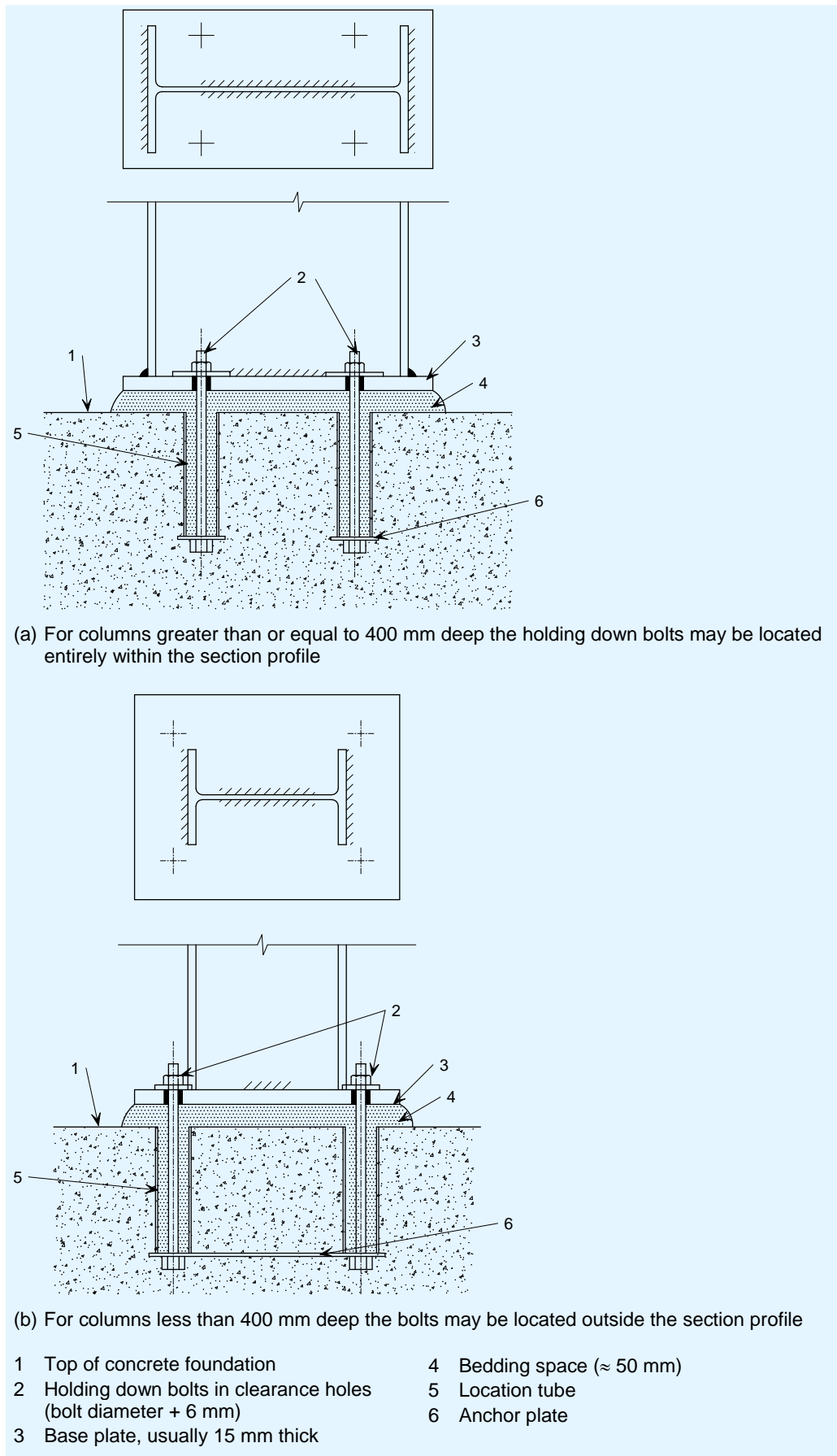

Figure 11.3 Typical nominally pinned bases

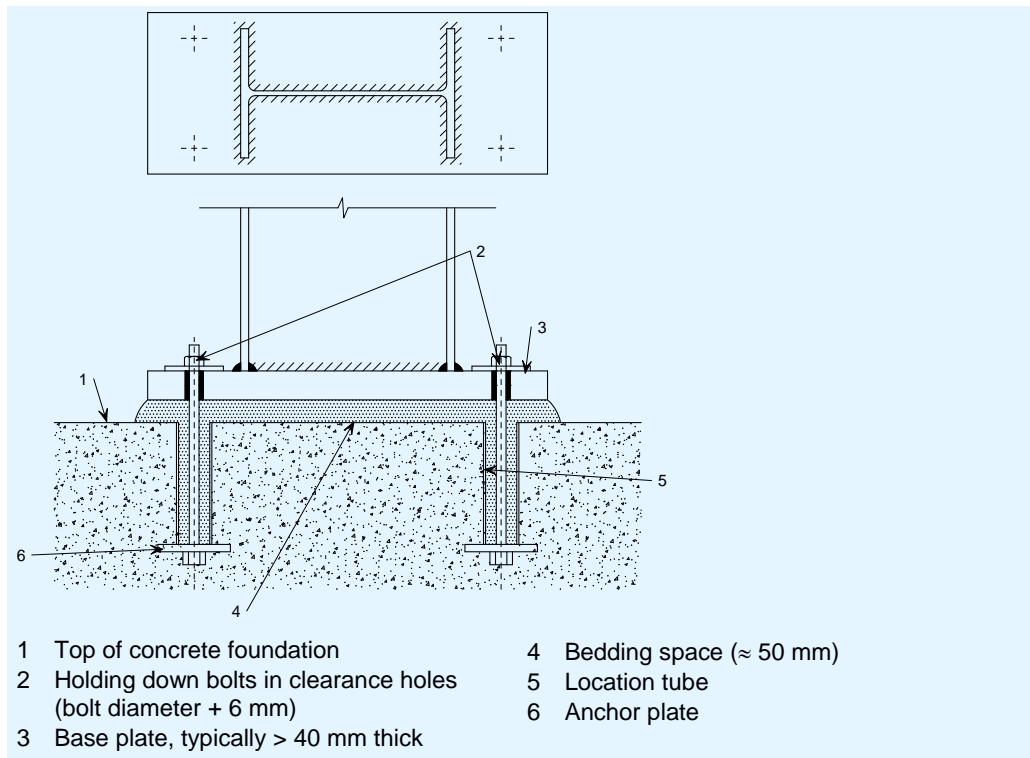

Figure 11.4 Typical nominally rigid moment resisting base

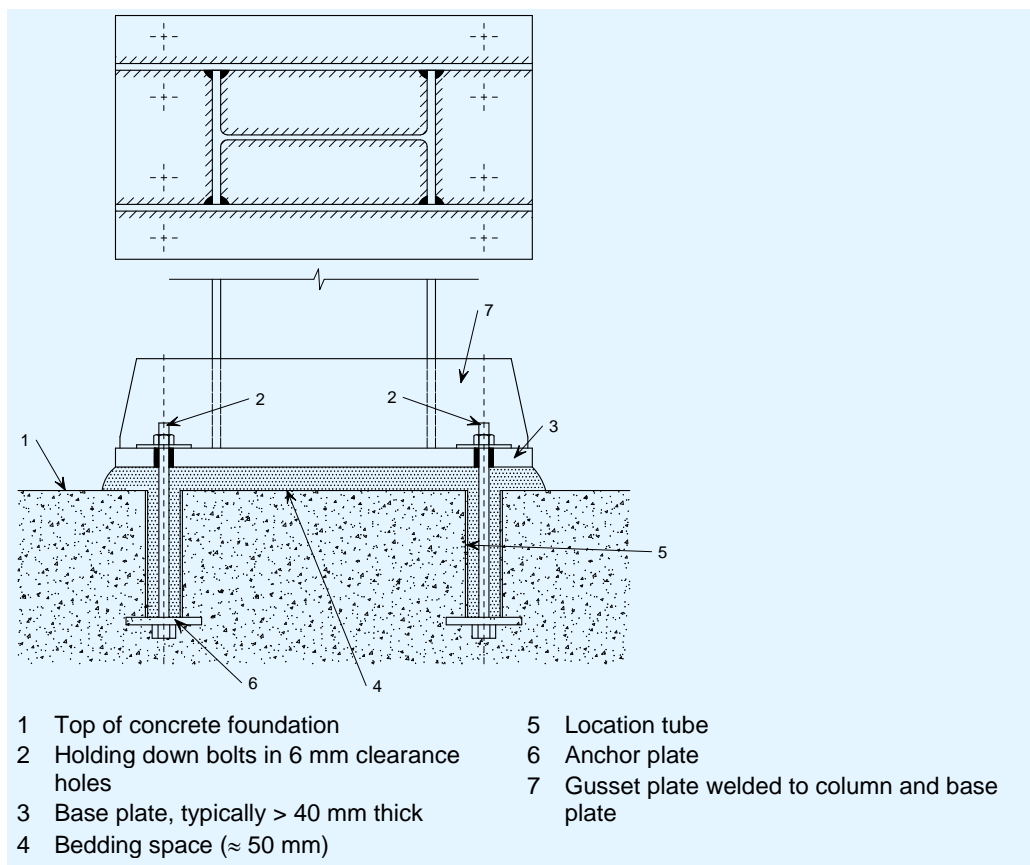

Figure 11.5 Nominally rigid, moment resisting base with gusset plates for high moments

11.3.2 Safety in erection

It is usual to provide at least four bolts in the base plate for stability during erection. The alternative is to provide temporary support immediately after the erection of the column, which on most sites would be impractical and is likely to create hazards.

11.3.3 Resistance to horizontal forces

The highest horizontal forces acting at the base of the column are generally those that act outwards as a result of bending in the column caused by vertical loading on the roof.

Horizontal reactions acting outwards can be resisted in a number of ways, by:

- Passive earth pressure on the side of the foundation, as indicated in Figure 11.6(a)
- A tie cast into the floor slab connected to the base of the column, as shown in Figure 11.6(b)
- A tie across the full width of the frame connecting both columns beneath or within the floor slab as illustrated in Figure 11.6(c) and (d).

By far the most popular method of resisting horizontal forces is to use passive earth pressure. This has economic advantages in that the foundation size required to resist uplift is usually adequate to provide adequate passive bearing against the ground. However, the passive resistance of the surrounding ground can be less than anticipated if the ground is not compacted correctly, and drainage and service trenches alongside the frame can reduce the passive resistance considerably.

As an alternative, a bar connected to the column and cast into the floor slab, and wrapped at the end to allow vertical movement, can be relatively cheap. This detail may lead to some local cracking of the floor slab and, where a high specification floor slab is used, the warranty on the slab may be invalidated. The length of the bar should be determined by the ultimate pull out resistance required to resist the horizontal force.

A tie across the full width of the frame connected to the column at each side is the most certain way of resisting horizontal forces. It is more expensive in terms of materials and labour and can be damaged by site activities. A full width tie will generally impede the erection of the structure, which will be undertaken from within the footprint of the building.

11.3.4 Base plates and holding down bolts

The steelwork contractor will usually be responsible for detailing the base plate and holding down bolts. However, it should be made clear in the contract documentation where the responsibility lies for the design of the foundation details, as special reinforcement spacing or details may be required.

Base plates will usually be in grade S235 or S275 steel.

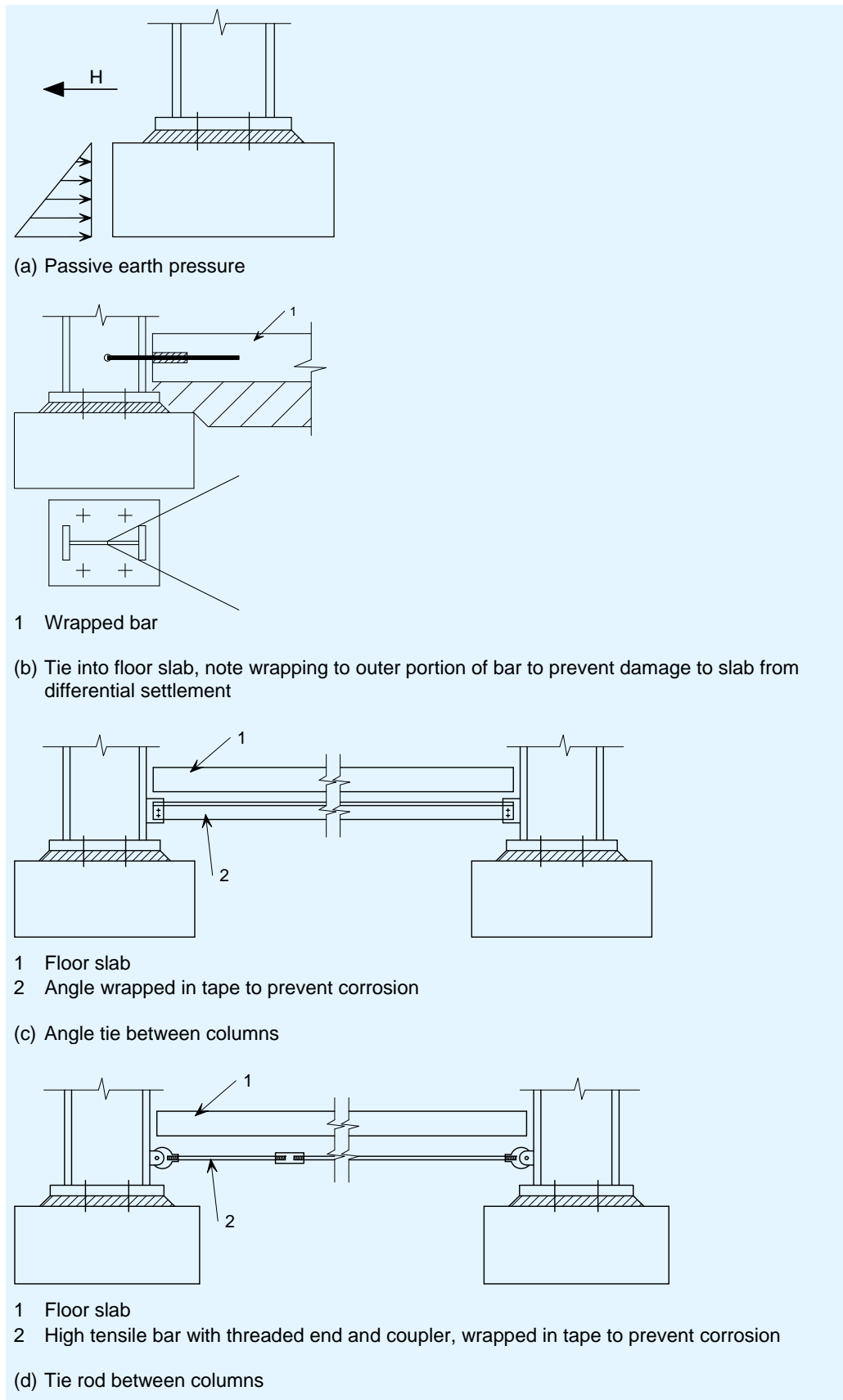

Figure 11.6 Methods of providing resistance to horizontal forces at the foundations

The diameter of the bolt will generally be determined by consideration of the uplift and shear forces applied to the bolts, but will not normally be less than 20 mm. There is often generous over-provision, to allow for the incalculable effects of incorrect location of bolts and combined shear force and bending on the bolt where grouting is incomplete.

The length of the bolt should be determined by the properties of the concrete, the spacing of the bolts, and the tensile force. A simple method of determining the embedment length is to assume that the bolt force is resisted by a conical surface of concrete. Where greater uplift resistance is required, angles or plates may be used to join the bolts together in pairs as an alternative to individual anchor plates. Calculations should be carried out by the designer at the final design stage to check the viability of the proposed bolt spacing.

11.3.5 Foundation design at the fire limit state

If the foundation is designed to resist a moment due to rafter collapse in a fire, both the base plate and the foundation itself should be designed to resist the moment as shown in Figure 11.7(a). It may be possible to offset the base to reduce or eliminate the eccentricity generated by the moment to give a uniform pressure distribution under the base as shown in Figure 11.7(b).

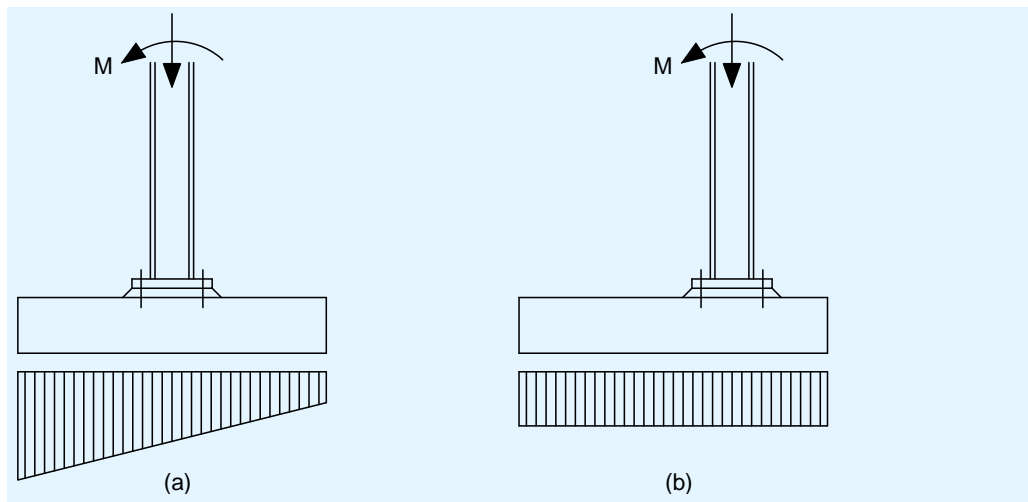

Figure 11.7 Foundation for portal frame in a fire boundary condition

11.4 Design summary

- Moment-resisting connections should be arranged to minimise any additional local strengthening.
- It is usually more economical to adopt nominally pinned column bases.
- Experience has demonstrated that a four bolt connection with a relatively thin base plate may behave effectively as a pin, while still providing sufficient stiffness for safe erection.
- Careful consideration needs to be given to resistance to shear forces, both in the column base and in the foundation.

12 SECONDARY STRUCTURAL COMPONENTS

12.1 Eaves beam

The cold-formed member that connects the individual frames at eaves level (indicated as (2) in Figure 12.1) is generally known as an eaves beam.

The primary function of the eaves beam is to support the roof cladding, side walls, and guttering along the eaves, but it may also be used to provide lateral restraint at the top of the outer flange of the column.

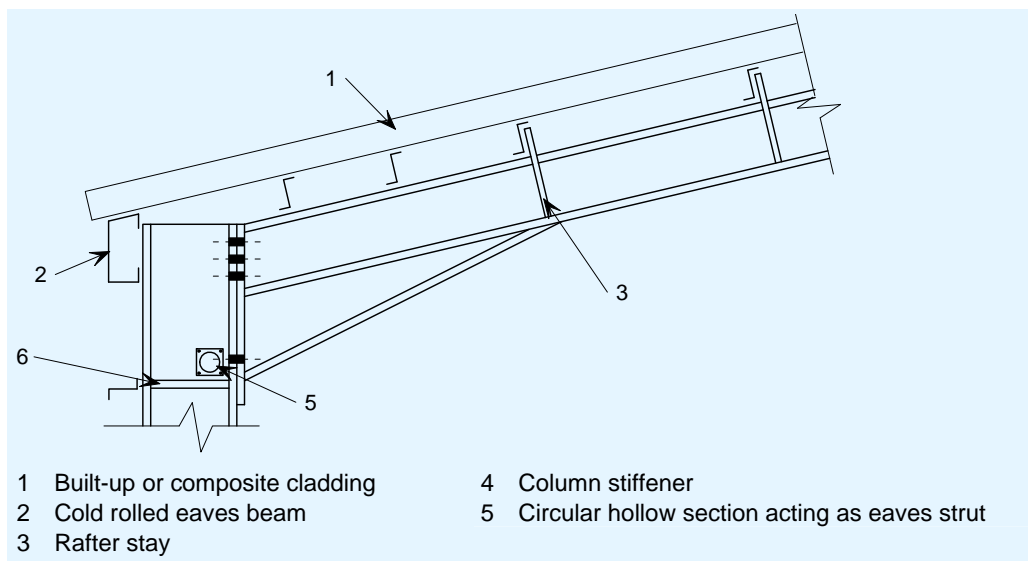

Figure 12.1 Haunch detail with eaves beam

12.2 Eaves strut

If vertical side wall bracing capable of resisting tension and compression is provided at both ends of the structure (see Section 9.2), an eaves strut is not required other than in the end bays. However, it is good practice to provide a member between the columns to act as a tie during erection and provide additional robustness to the structure.

If a circular hollow section is used to restrain the plastic hinge at the bottom of the eaves as illustrated in Figure 12.1, this can fulfil the role of a longitudinal strut as well as restraining the plastic hinge. If a member is provided as an eaves strut above this level, it is ineffective in restraining the plastic hinge at the bottom of the haunch.

13 DESIGN OF MULTI-BAY PORTAL FRAMES

13.1 General

Most aspects of the behaviour and design of multi-bay portal frames are similar to single bay structures. This Section describes common types of multi-bay frames and highlights key points of difference.

13.2 Types of multi-bay portals

13.2.1 Valley beams and 'hit' and 'miss' frames

In multi-span portal framed building, it is common practice to use valley beams to eliminate some internal columns. Most commonly, alternate columns are omitted and the valley of the frame is supported on a so-called valley beam spanning between the columns of adjacent frames, as shown in Figure 13.1. This arrangement is often referred to as 'hit' and 'miss' frames, the frames with columns being the 'hit' frames. Sometimes more than one column is omitted, though such schemes require very large valley beams and reduce the stiffness and the stability requirements of the structure, even where the remaining complete frames are used to stabilise the frames without columns.

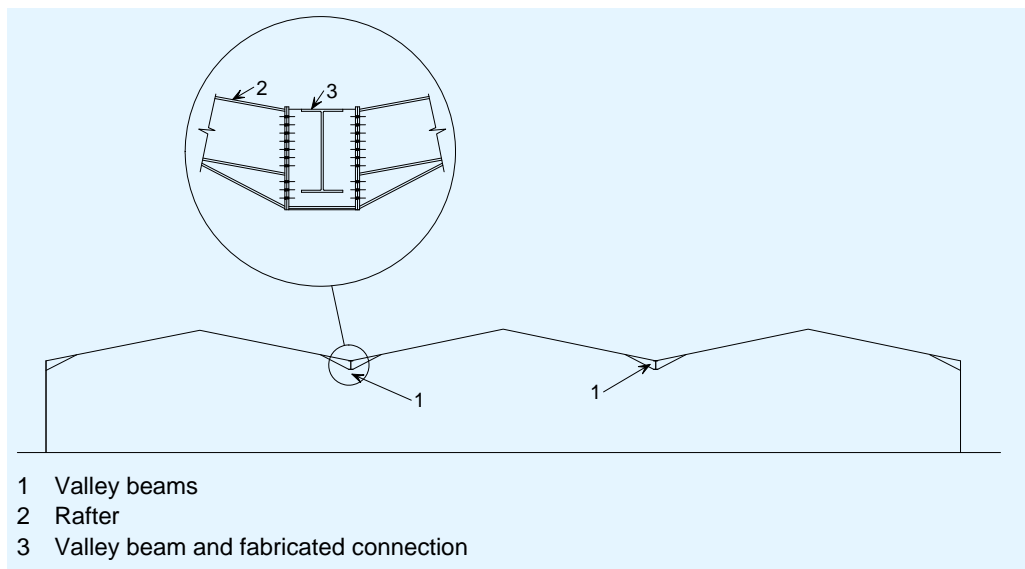

Figure 13.1 Valley beams

Valley beams may be simply supported or continuous through the supporting columns. The choice will normally depend on the relative cost of a heavier beam for simply supported construction and the more expensive connection for continuous construction.

Valley beams often form one or more rigid frames with the internal columns along the valley to provide overall structural stability at right angles to the frames. This avoids the use of cross bracing on the internal column lines, which is often unacceptable for the intended use of the building. Alternatively, a deep truss may be provided in the plane of the rafters, which spans between the external elevations. For long trusses on multi-span structures, it would be

common to provide a truss which is two bays deep, rather than a truss in the end bay only.

13.3 Stability

The majority of multi-span portal frames have slender internal columns. When a horizontal load is applied to these frames, there is only a small bending moment induced in these slender internal columns, because the external columns are much stiffer. A typical bending moment diagram is shown in Figure 13.2.

This difference in bending moment distribution and the associated reduction in internal column stiffness has a significant impact on frame behaviour. At the Ultimate Limit State, the frame is likely to be operating at 20 to 30% of its overall elastic critical load. With the spread of plasticity from the critical hinge position, the effective critical load will reduce, increasing the effective critical load ratio further.

This effect is addressed by appropriate second order, elastic / plastic software.

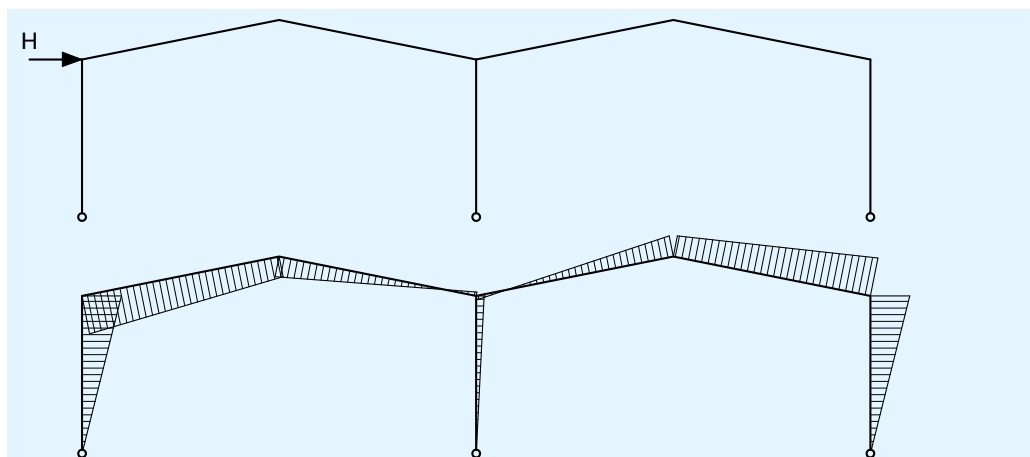

Figure 13.2 Bending moments in a typical two-span frame under horizontal loading

The frame in Figure 13.2 can be considered as two sub-frames, each comprising an external column and a rafter pair, as shown in Figure 13.3. For multi-span frames in general, the two external sub-frames provide the majority of the stiffness, so the same model of a pair of sub-frames could be used for hand calculations. Where the stiffness of the internal columns is to be included, it is preferable to use software for the analysis of the entire frame.

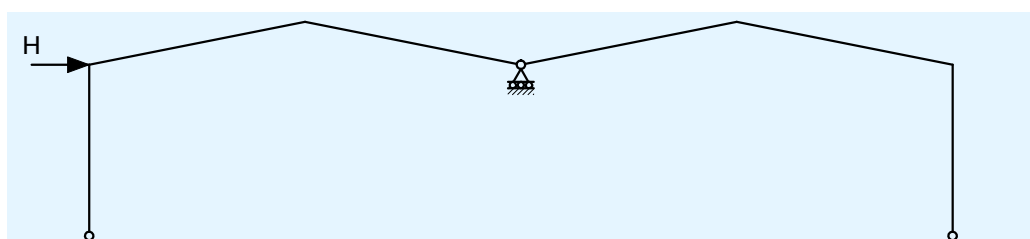

Figure 13.3 Sub-frames for a typical two-span frame

Where the internal columns provide significant stiffness, it is uneconomic to ignore them and a detailed analysis of the entire frame by software would be preferable.

13.4 Snap through instability

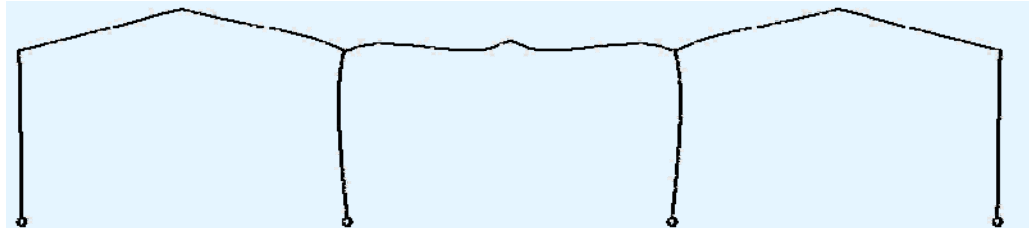

Figure 13.4 Snap through instability

As shown in Figure 13.4, the reduced sway stiffness of frames with three or more bays may lead to snap through instability of an internal bay. Such structures may be checked with appropriate software to ensure satisfactory behaviour. Appendix B may be used to calculate an estimate of the sensitivity to snap through.

13.5 Design summary

- Many aspects of behaviour of multi-bay portal frames are similar to single bay frames
- Special consideration should be given to the sway stability and snap through stability of multi-bay frames.

REFERENCES

- 1 EN 1993-1-1: Eurocode 3 Design of steel structures. General rules and rules for building
- 2 Steel Buildings in Europe
Single-storey steel buildings. Part 2: Concept design
- 3 FISHER, J.M.
Industrial buildings
Chapter 6.1 in Construction steel design: an international guide
Elsevier Applied Science, London, 1992
- 4 HORNE, M.R. and AJMANI, J.L.
Failure of columns laterally supported on one flange: Discussion
The structural Engineer, Vol. 51, No. 7, July 1973
- 5 Steel Buildings in Europe
Single-storey Buildings. Part 11: Moment connections
- 6 LIM, J, KING, C.M, RATHBONE, A, DAVIES, J.M and EDMONDSON, V
Eurocode 3: The in-plane stability of portal frames
The Structural Engineer, Vol. 83. No 21, 1st November 2005

APPENDIX A Practical deflection limits for single-storey buildings

A.1 Horizontal deflections for portal frames

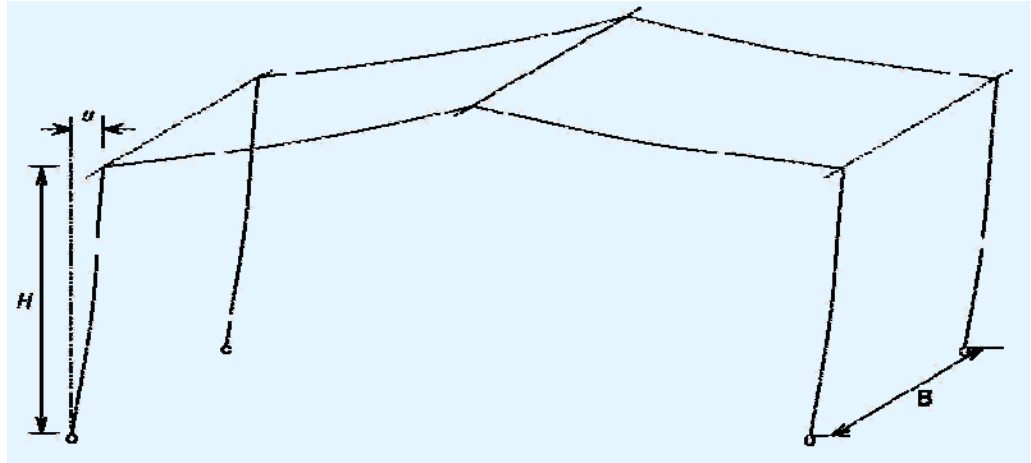

Figure A.1 Definition of horizontal deflection

Horizontal deflection limits for portal frame structures are not explicitly covered in the structural Eurocodes. Generally, limits are set nationally, either by regulation or by accepted industry practice.

Typical limiting values for horizontal deflection are given in Table A.1.

Table A.1 Typical horizontal deflection limits

Country	Structure	Deflection limits <i>u</i>	Comments
France	Portal frames without gantry cranes Buildings with no particular requirements regarding the deflection.		Values are given in the French National Annex to EN 1993-1-1 and should be used if nothing else is agreed with the client. The values of the deflections calculated from the characteristic combinations should be compared to these limits.
	Deflection at the top of the columns	<i>H/150</i>	
	Difference of deflection between two consecutive portal frames	<i>B/150</i>	
	Member supporting metal cladding		
	Post	<i>H/150</i>	
	Rail	<i>B/150</i>	
	Other single-storey buildings Buildings with particular requirements regarding the deflection (brittle walls, appearance etc..)		
	Deflection at the top of the columns	<i>H/250</i>	
	Difference of deflection between two consecutive portal frames	<i>B/200</i>	
Germany			There are no national deflection limits. The limits should be taken from manufacturers instructions (technical approvals) or should be agreed with the client.
Spain	Portal frames (without fragile elements susceptible to failure in the envelopes, façade and roof)	<i>H/150</i>	Values are given in the national technical document for steel structures] and in the Technical Building Code and should be used if nothing else is agreed with the client.
	Single-storey buildings with horizontal roofs (without fragile elements susceptible to failure in the envelopes, façade and roof)	<i>H/300</i>	

A.2 Vertical deflections for portal frames

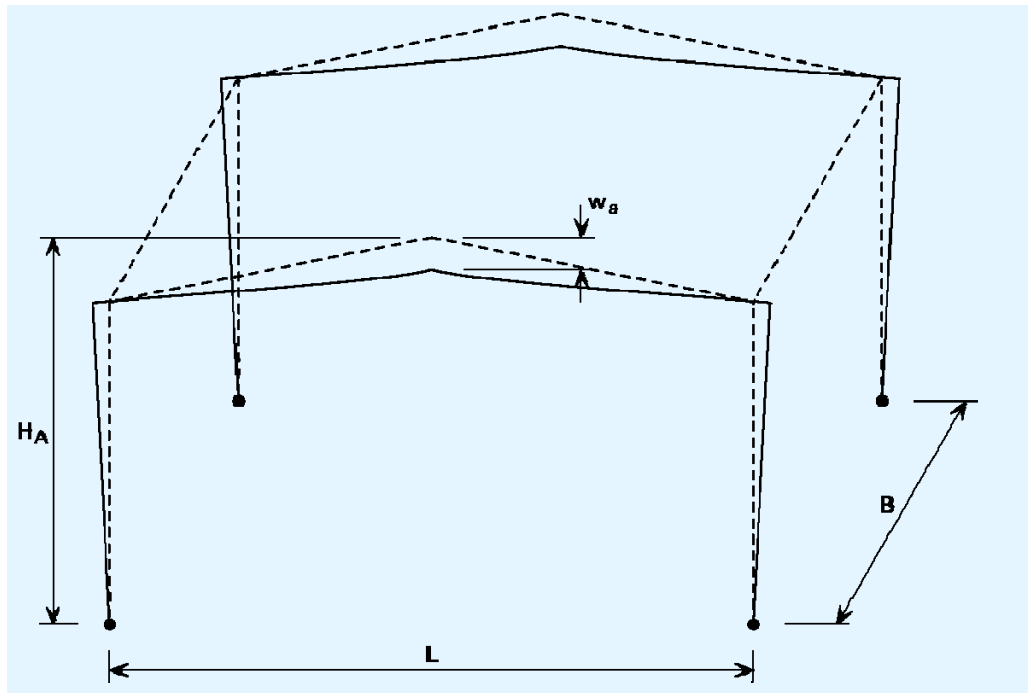

Figure A.2 Definitions of vertical deflection of apex of portal frame

Typical limiting values for vertical deflection for some countries are given in Table A.2.

Table A.2 Vertical deflection limits

Country	Structure	Deflection limits		Comments
		w_{max}	w_3	
France	Roofs in general	$L/200$	$L/250$	Values are given in the National Annex to EN 1993-1-1 and should be used if nothing else is agreed with the client. The values of the deflections calculated from the characteristic combinations should be compared to these limits.
	Roofs frequently carrying personnel other than for maintenance	$L/200$	$L/300$	
	Roofs supporting plaster or other brittle toppings or non-flexible parts	$L/250$	$L/350$	
Germany				There are no national deflection limits. The limits should be taken from manufacturers instructions (technical approvals) or should be agreed with the client.

A.2.1 Vertical deflections for horizontal roof members

Serviceability limit states

Guidance for deflection limits are given in Table A.3 for a selection of European countries. The definition of vertical deflection in Annex A to EN 1990 is reproduced in Figure A.3.

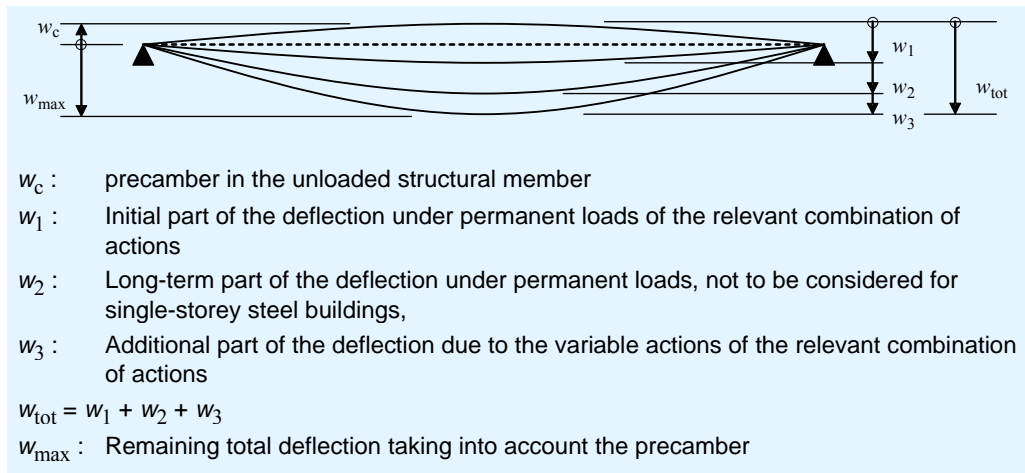

Figure A.3 Definition of vertical deflections

Table A.3 Recommended limiting values for vertical deflections

Country	Structure	Deflection limits		Comments
		w_{max}	w_a	
France	Roofs in general	$L/200$	$L/250$	Values are given in the National Annex to EN 1993-1-1 and should be used if nothing else is agreed with the client. The values of the deflections calculated from the characteristic combinations should be compared to these limits.
	Roofs frequently carrying personnel other than for maintenance	$L/200$	$L/300$	
	Roofs supporting plaster or other brittle toppings or non-flexible parts	$L/250$	$L/350$	
Germany				There are no national deflection limits. The limits should be taken from manufacturers' instructions (technical approvals) or should be agreed with the client.
Spain	Roofs in general	$L/300(*)$	-	Values are given in the national technical document for steel structures and in the Technical Building Code and should be used if nothing else is agreed with the client.
	Roofs with access only for maintenance	$L/250(*)$		

(*) This values refers to $w_2 + w_3$ but $w_2 = 0$ for steel structures.

Ultimate limit state: Ponding

Where the roof slope is less than 5%, additional calculations should be made to check that collapse cannot occur due to the weight of water:

- either collected in pools which may be formed due to the deflection of structural members or roofing material
- or retained by snow.

These additional checks should be based on the combinations at the Ultimate Limit States.

Precambering of beams may reduce the likelihood of rainwater collecting in pools, provided that rainwater outlets are appropriately located.

APPENDIX B Calculation of $\alpha_{cr,est}$

B.1 General

EN 1993-1-1 § 5.2.1 (4) B gives:

$$\alpha_{cr} = \left(\frac{H_{Ed}}{V_{Ed}} \right) \left(\frac{h}{\delta_{H,Ed}} \right)$$

However, this can only be applied when the axial load in the rafter is not significant. Note 2B of § 5.2.1(4)B describes significant as when

$\bar{\lambda} \geq 0,3 \sqrt{\frac{Af_y}{N_{Ed}}}$, which may be rearranged to indicate that the axial load is not significant when $N_{Ed} \leq 0,09 N_{cr}$

Where:

N_{cr} is the elastic critical buckling load for the complete span of the rafter pair, i.e. $N_{cr} = \frac{\pi^2 EI}{L^2}$

L is the developed length of the rafter pair from column to column, taken as span/Cos θ (θ is the roof slope).

If the axial load in the rafter exceeds this limit, the expression in EN 1993-1-1 cannot be used.

An alternative expression, accounting for the axial force in the rafter, has been developed by J. Lim and C. King^[6] and is detailed below.

For frames with pitched rafters:

$$\alpha_{cr,est} = \min (\alpha_{cr,s,est}; \alpha_{cr,r,est})$$

where:

$\alpha_{cr,s,est}$ is the estimate of α_{cr} for sway buckling mode

$\alpha_{cr,r,est}$ is the estimate of α_{cr} for rafter snap-through buckling mode. This mode need only be checked when there are three or more spans, or if the rafter is horizontal, or when the columns are not vertical.

B.2 Factor $\alpha_{cr,s,est}$

The parameters required to calculate $\alpha_{cr,s,est}$ for a portal frame are shown in Figure B.1. δ_{NHF} is the lateral deflection at the top of each column when subjected to a notional lateral force H_{NHF} . (The magnitude of the total lateral force is arbitrary, as it is simply used to calculate the sway stiffness). The horizontal force applied at the top of each column should be proportional to the vertical reaction.

The practical application of this recommendation is to calculate H_{NHF} as 1/200 of the vertical reaction at the base of the column. In combinations including wind actions, H_{NHF} should still be calculated as 1/200 of the vertical reaction at the base.

In calculating δ_{NHF} only the notional lateral forces, H_{NHF} , are applied to the frame. Base stiffness may be included in the analysis (as described in Section 3.4).

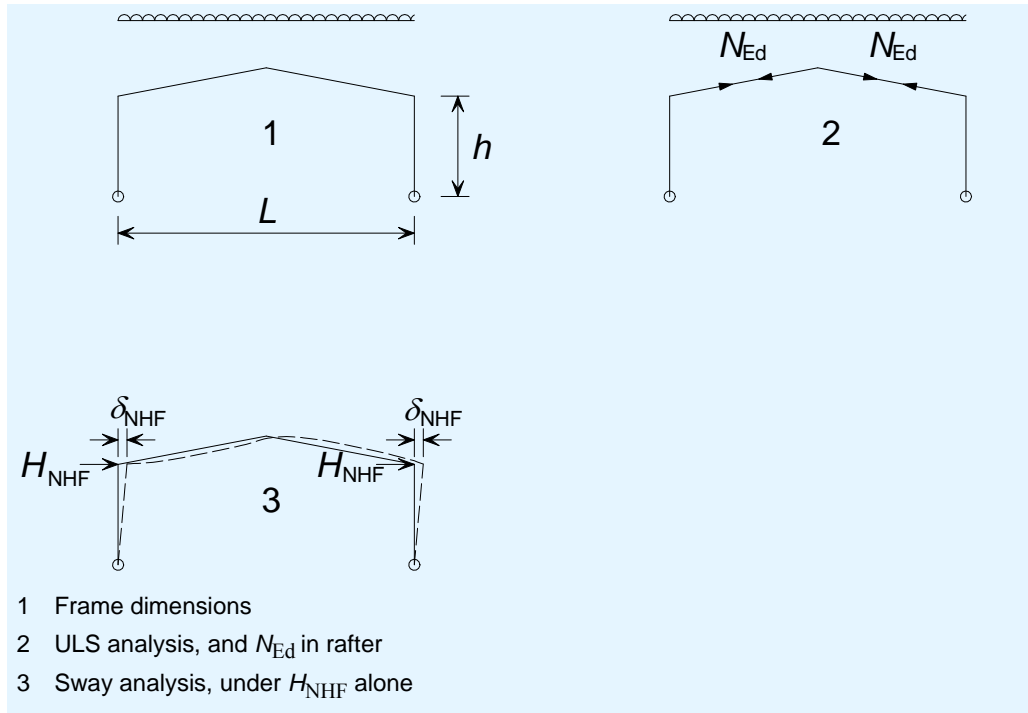

Figure B.1 Calculation of α_{cr}

α_{cr} can then be calculated as:

$$\alpha_{\text{cr}} = \frac{h}{200\delta_{\text{NHF}}}$$

The lowest value of α_{cr} for any column is taken for the frame as a whole.

$\alpha_{\text{cr,s,est}}$ can then be calculated as:

$$\alpha_{\text{cr,s,est}} = 0,8 \left\{ 1 - \left(\frac{N_{\text{Ed}}}{N_{\text{cr,R}}}_{\text{max}} \right) \right\} \alpha_{\text{cr}}$$

where:

$\left(\frac{N_{\text{Ed}}}{N_{\text{cr,R}}}_{\text{max}} \right)$ is the maximum ratio in any rafter

N_{Ed} is the axial force in rafter at ULS (see Figure B.1)

$N_{\text{cr,R}} = \frac{\pi^2 EI_{\text{r}}}{L^2}$ is the Euler load of the rafter for the full span of the rafter pair (assumed pinned).

Part 4: Detailed Design of Portal Frames

- L is the developed length of the rafter pair from column to column, taken as span/Cos θ (θ is the roof slope)
- I_r is the in-plane second moment of area of rafter

Factor $\alpha_{cr,r,est}$

This calculation should be carried out if the frame has three or more spans, or if the rafter is horizontal.

For frames with rafter slopes not steeper than 1:2 (26°), $\alpha_{cr,r,est}$ may be taken as:

$$\alpha_{cr,r,est} = \left(\frac{D}{L} \right) \left(\frac{55,7(4 + L/h)}{\Omega - 1} \right) \left(\frac{I_c + I_r}{I_r} \right) \left(\frac{275}{f_{yr}} \right) (\tan 2\theta_r)$$

But where $\Omega \leq 1$, $\alpha_{cr,r,est} = \infty$

where:

- D is cross-sectional depth of rafter, h
- L is span of bay
- h is mean height of column from base to eaves or valley
- I_c is in-plane second moment of area of the column (taken as zero if the column is not rigidly connected to the rafter, or if the rafter is supported on a valley beam)
- I_r is in-plane second moment of area of the rafter
- f_{yr} is nominal yield strength of the rafters in N/mm²
- θ_r is roof slope if roof is symmetrical, or else $\theta_r = \tan^{-1}(2h_r/L)$
- h_r is height of apex of roof above a straight line between the tops of columns
- Ω is arching ratio, given by $\Omega = W_r/W_0$
- W_0 is value of W_r for plastic failure of rafters as a fixed ended beam of span L
- W_r is total factored vertical load on rafters of bay.

If the two columns or two rafters of a bay differ, the mean value of I_c should be used.

APPENDIX C Determination of M_{CR} and N_{CR}

C.1 M_{CR} for uniform members

C.1.1 General expression

The method given in C.1.1 only applies to uniform straight members for which the cross-section is symmetric about the bending plane.

$$M_{cr} = C_1 \frac{\pi^2 EI_z}{(kL)^2} \left\{ \sqrt{\left(\frac{k}{k_w}\right)^2 \frac{I_w}{I_z} + \frac{(kL)^2 GI_t}{\pi^2 EI_z} + (C_2 z_g)^2} - C_2 z_g \right\}$$

In the case of a portal frame, $k = 1$ and $k_w = 1$. The transverse load is assumed to be applied at the shear centre and therefore $C_2 z_g = 0$. The expression may be simplified to:

$$M_{cr} = C_1 \frac{\pi^2 EI_z}{L^2} \sqrt{\frac{I_w}{I_z} + \frac{L^2 GI_t}{\pi^2 EI_z}}$$

E is Young modulus ($E = 210000 \text{ N/mm}^2$)

G is the shear modulus ($G = 81000 \text{ N/mm}^2$)

I_z is the second moment of area about the weak axis

I_t is the torsional constant

I_w is the warping constant

L is the beam length between points of lateral restraint

C_1 depends on the shape of the bending moment diagram

C.1.2 C_1 factor

The factor C_1 may be determined from Table C.1 for a member with end moment loading, and also for members with intermediate transverse loading.

Table C.1 C_1 factor

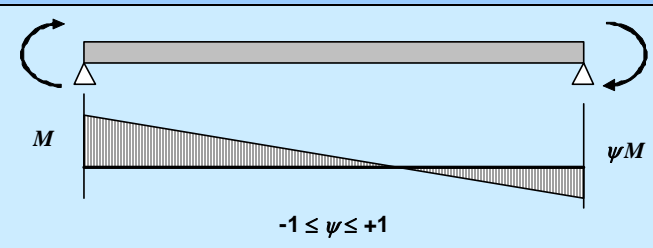
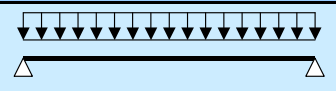
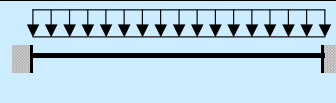
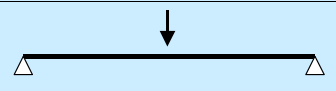
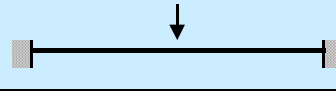
End Moment Loading	ψ	C_1
	+1,00	1,00
	+0,75	1,17
	+0,50	1,36
	+0,25	1,56
	0,00	1,77
	-0,25	2,00
	-0,50	2,24
	-0,75	2,49
	-1,00	2,76
Intermediate Transverse Loading		
	0,94	1,17
	0,62	2,60
	0,86	1,35
	0,77	1,69

C.2 M_{cr} for members with discrete restraints to the tension flange

It is possible to take beneficial account of restraints to the tension flange. This may lead to a greater buckling resistance of the member.

Tension flange restraint is usually provided by elements connected to the tension flange of the member (e.g. purlins).

The spacing between tension flange restraints must satisfy the requirements for L_m as given in § BB.3.1.1 in EN 1993-1-1.

C.2.1 General expression

For the general case of a beam of varying depth but symmetrical about the minor axis, subject to a non-uniform moment:

$$M_{cr} = c^2 C_m M_{cr0} \quad \text{for beams with a linearly varying moment diagram}$$

or

$$M_{cr} = c^2 C_n M_{cr0} \quad \text{for beams with a non-linearly varying moment diagram}$$

where

M_{cr0} is the critical moment for a beam subject to uniform moment.
Expressions of M_{cr0} is given in C.2.2

c accounts for taper ($c = 1$ for uniform straight member)

The value of c is given by EN 1993-1-1 Annex BB.3.3.3 based on the

depth at the shallower end of the member and limited to members where $1 \leq h_{\max}/h_{\min} \leq 3$. Note that the expression for c was derived in reference 4 for elements with $\bar{\lambda} \leq 1.05$, which is the common case for haunches in portal frames

- C_m accounts for linear moment gradients. The value is given by the Expression BB.13 of EN 1993-1-1 Annex BB. It is recommended that $C_m \leq 2,7$
- C_n accounts for non-linear moment gradients. The value is given by the Expression BB.14 of EN 1993-1-1 Annex BB. It is recommended that $C_n \leq 2,7$

When using EN 1993-1-1 Annex BB.3.3.2, the following points need clarification:

The same definition of ‘positive’ and ‘negative’ moments applies as in BB.3.3.1: Moments that produce compression in the non-restrained flange should be taken as positive.

This is fundamental as only positive values of R should be taken.

BB.3.3.2 assumes that the loads are applied at the shear centre.

C.2.2 Calculation of M_{cr0}

For uniform sections, symmetric about the minor axis, restrained along the tension flange at intervals:

$$M_{cr0} = \frac{1}{2a} \left(\frac{\pi^2 EI_z a^2}{L_t^2} + \frac{\pi^2 EI_w}{L_t^2} + GI_t \right)$$

$$\text{but } M_{cr0} \leq \frac{\pi^2 EI_z}{s^2} \sqrt{\frac{I_w}{I_z} + \frac{s^2 GI_t}{\pi^2 EI_z}}$$

where:

- a is the distance between the restrained longitudinal axis (e.g. the centroid of the purlins) and the shear centre of the member. This takes account of the fact that the effective restraint is provided slightly away from the flange
- L_t is the length of the segment along the member between torsional restraints to both flanges
- s is the distance between the restraints along the restrained longitudinal axis (e.g. the spacing of the purlins).

For tapered or haunched members, M_{cr0} is calculated using the section properties of the shallow ends.

The parameters a , L_t and s are shown in Figure C.1

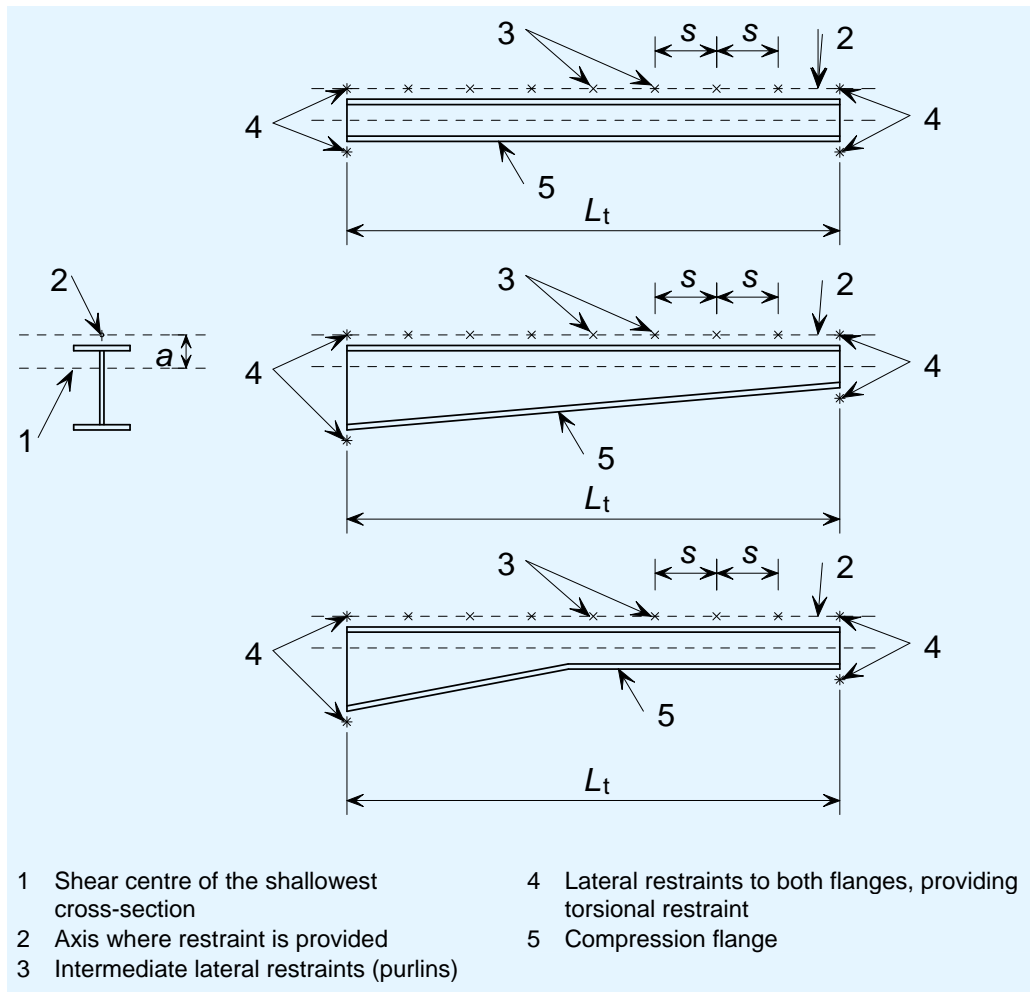

Figure C.1 Arrangement of tension flange restraints

C.3 N_{cr} for uniform members with discrete restraints to the tension flange

It is possible to take beneficial account of restraints to the tension flange. This may lead to a greater buckling resistance of the member.

Tension flange restraint is usually provided by elements connected to the tension flange of the member (e.g. purlins).

C.3.1 General expression

For Class 1, 2, and 3 cross-sections, § 6.3.1.2 of EN 1993-1-1 gives

$$\bar{\lambda} = \sqrt{\frac{Af_y}{N_{cr}}} \quad \text{where } N_{cr} = \frac{\pi^2 EI}{L^2} \quad \text{for flexural buckling}$$

C.3.2 N_{crT} for uniform members with discrete restraints to the tension flange

The elastic critical buckling force for an I section with intermediate restraints to the tension flange is given in BB.3.3.1 as:

$$N_{crT} = \frac{1}{i_s^2} \left(\frac{\pi^2 EI_z a^2}{L_t^2} + \frac{\pi^2 EI_w}{L_t^2} + GI_t \right)$$

where:

$$i_s^2 = i_y^2 + i_z^2 + a^2$$

L_t is the length of the segment along the member between torsional restraints to both flanges

a is defined in C.1.

For tapered or haunched members, N_{crT} is calculated using the section properties of the shallow ends.

APPENDIX D

Worked Example: Design of portal frame using elastic analysis

1. Elastic analysis of a single bay portal frame

This example covers the design of a portal frame for a single-storey building, using the elastic method of global analysis. Only gravity loads are covered in this example. The frame uses hot rolled I sections for rafters and columns.

2. Frame geometry

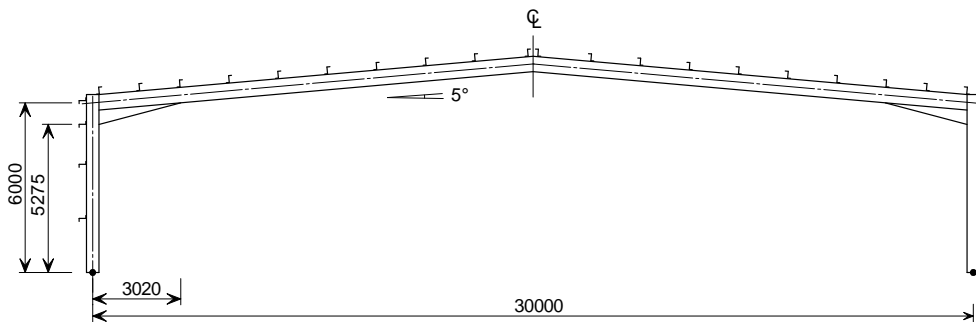

Spacing of portal frames = 7,2 m

The cladding to the roof and walls is supported by purlins and side rails.

The purlins have been provisionally located at intervals of between 1500 mm and 1800 mm as shown. The side rails are provisionally located at intervals of no more than 2000 mm. The rafter and column verifications may require these locations to be modified.

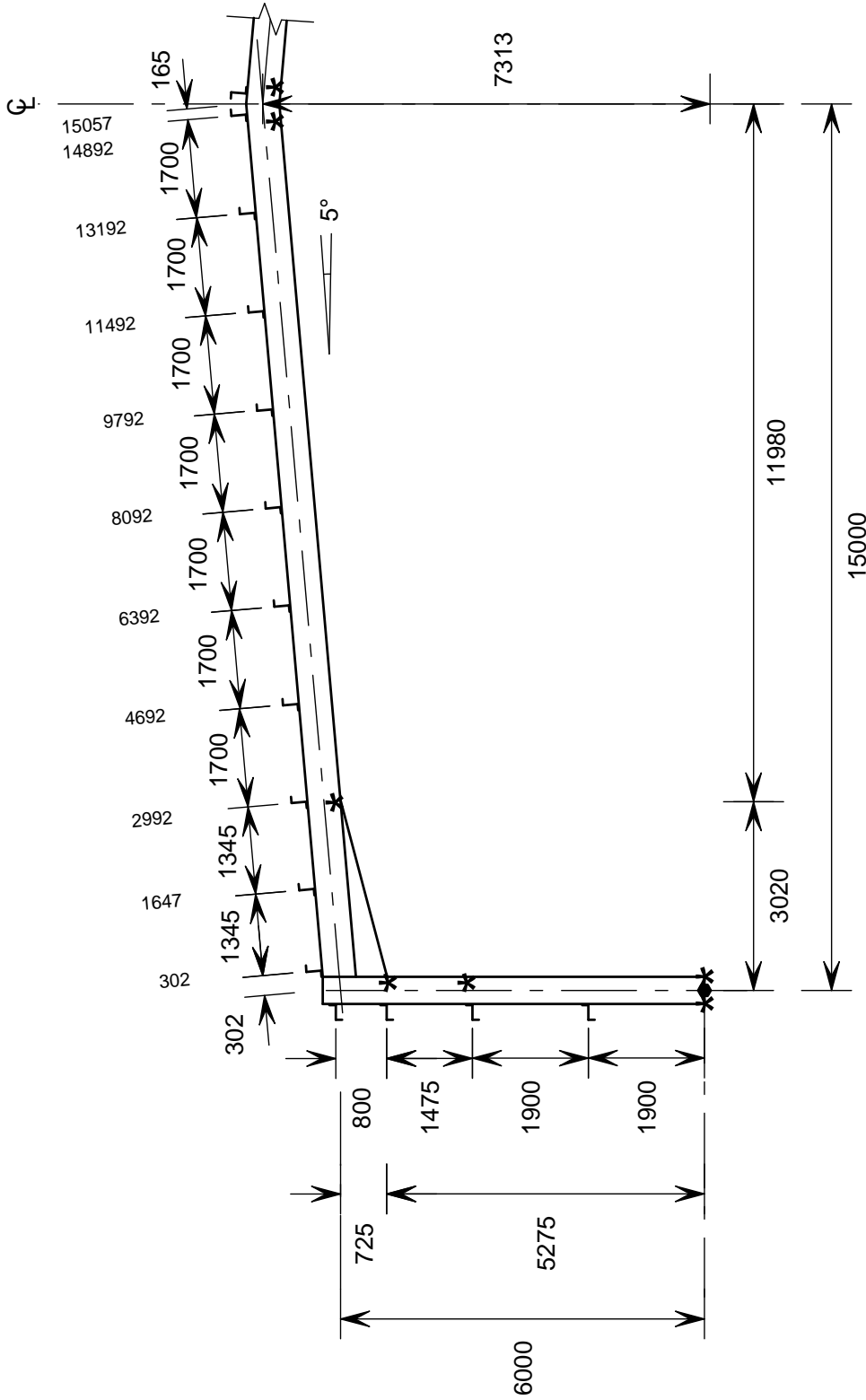

* torsional restraint to inside flange

3. Loads

3.1. Permanent loads

$$G = G_{\text{self-weight}} + G_{\text{roof}}$$

$G_{\text{self-weight}}$: self-weight of the beams

G_{roof} : roofing with purlins $G_{\text{roof}} = 0,30 \text{ kN/m}^2$

$$\Rightarrow \text{for an internal frame: } G_{\text{roof}} = 0,30 \times 7,20 = 2,16 \text{ kN/m}$$

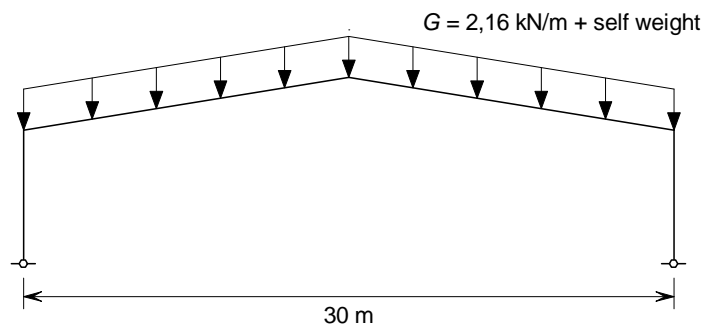

EN 1991-1-1

3.2. Snow loads

The characteristic value for snow loading on the roof for a specific location in a given country at certain altitude has been calculated as:

$$s_k = 0,618 \text{ kN/m}^2$$

$$\Rightarrow \text{for an internal frame: } s = 0,618 \times 7,20 = 4,45 \text{ kN/m}$$

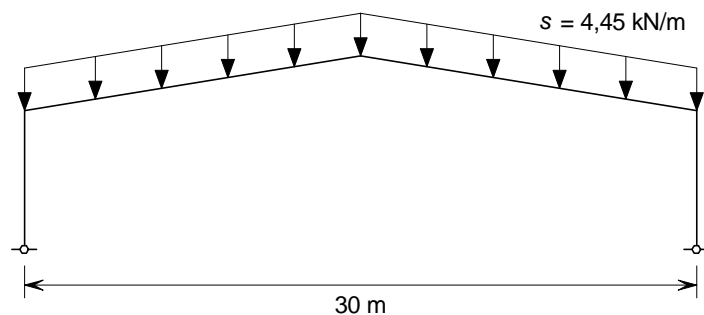

EN 1991-1-3

3.3. Imposed load on roof

Characteristic values for loading on the roof (type H: not accessible).

$$q_k = 0,4 \text{ kN/m}^2$$

$$\Rightarrow \text{for an internal frame: } q_k = 0,4 \times 7,20 = 2,88 \text{ kN/m}$$

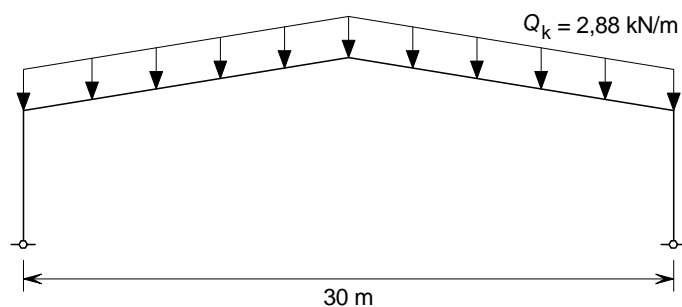
EN 1991-1-1
Table 6.10

Title	APPENDIX D Worked Example: Design of portal frame using elastic analysis	4 of 44
<p>3.4. Load combinations</p> <p>For simplicity, the wind actions are not considered in this example.</p> <p>Therefore, the critical design combination for choosing the member size is: $\gamma_G G + \gamma_Q Q$</p> <p>Where:</p> <p>Q is the maximum of the snow load and the imposed load.</p> <p>$\gamma_G = 1,35$ (permanent actions)</p> <p>$\gamma_Q = 1,50$ (variable actions)</p> <p>The snow loads are greater than the imposed loads on the roof, therefore $Q = 4,45$ kN/m</p> <p>4. Preliminary sizing</p> <p><i>Single-storey steel buildings. Part 2: Concept design</i> ^[2] provides a table of preliminary member sizes, according to the rafter load and the height to eaves.</p> <p>Rafter load = $1,35(2,16 + \text{self weight}) + 1,5 \times 4,45 = 9,6$ kN/m + self weight Say 10 kN/m to include self weight.</p> <p>The section chosen for the rafter is an IPE 450, S355</p> <p>The section chosen for the column is an IPE 500, S355</p> <p>5. Buckling amplification factor α_{cr}</p> <p>In order to evaluate the sensitivity of the frame to 2nd order effects, the buckling amplification factor, α_{cr}, has to be calculated. This calculation requires the deflections of the frame to be known under a given load combination.</p> <p>An elastic analysis is performed to calculate the reactions under vertical loads at ULS, which provides the following information:</p> <p>The vertical reaction at each base: $V_{Ed} = 168$ kN</p> <p>The horizontal reaction at each base: $H_{Ed} = 116$ kN</p> <p>The maximum axial force in the rafters: $N_{R,Ed} = 130$ kN</p> <p>5.1. Axial compression in the rafter</p> <p>According to the code, if the axial compression in the rafter is significant then α_{cr} is not applicable. In such situations, Appendix B of this document recommends the use of $\alpha_{cr,est}$ instead.</p> <p>The axial compression is significant if $\bar{\lambda} \geq 0,3 \sqrt{\frac{A f_y}{N_{Ed}}}$</p> <p>or if $N_{Ed} \geq 0,09 N_{cr}$, which is an equivalent expression.</p> <p>N_{Ed} is the design axial load at ULS in the rafter, noted $N_{R,Ed}$ in this example.</p>		<p>EN 1990</p> <p>EN 1993-1-1 §5.2.1</p> <p>EN 1993-1-1 §5.2.1(4) Note 2B</p>

L_{cr} is the developed length of the rafter pair from column to column.

$$L_{cr} = \frac{30}{\cos 5^\circ} = 30,1 \text{ m}$$

$$N_{cr} = \frac{\pi^2 EI_z}{L_{cr}^2} = \frac{\pi^2 \times 210000 \times 33740 \times 10^4}{(30,1 \times 10^3)^2} \times 10^{-3} = 772 \text{ kN}$$

$$0,09 N_{cr} = 0,09 \times 772 = 69 \text{ kN}$$

$$N_{R,Ed} = 130 \text{ kN} > 69 \text{ kN}$$

Therefore the axial compression in the rafter is significant and α_{cr} from EN 1993-1-1 is not applicable.

Following the guidance from Appendix B, frame stability is assessed based on $\alpha_{cr,est}$, in Section 5.2.

5.2. Calculation of $\alpha_{cr,est}$

For a pitched roof frame: $\alpha_{cr,est} = \min(\alpha_{cr,s,est}; \alpha_{cr,r,est})$

$\alpha_{cr,r,est}$ only needs to be checked for portal frames of 3 or more spans.

When assessing frame stability, allowance can be made for the base stiffness. In this example, a base stiffness equal to 10% of the column stiffness has been assumed to allow for the nominally pinned bases.

To calculate α_{cr} , a notional horizontal force is applied to the frame and the horizontal deflection of the top of the columns is determined under this load.

The notional horizontal force is:

$$H_{NHF} = \frac{1}{200} V_{Ed} = \frac{1}{200} \times 168 = 0,84 \text{ kN}$$

The horizontal deflection of the top of the column under this force is obtained from the elastic analysis as 1,6 mm.

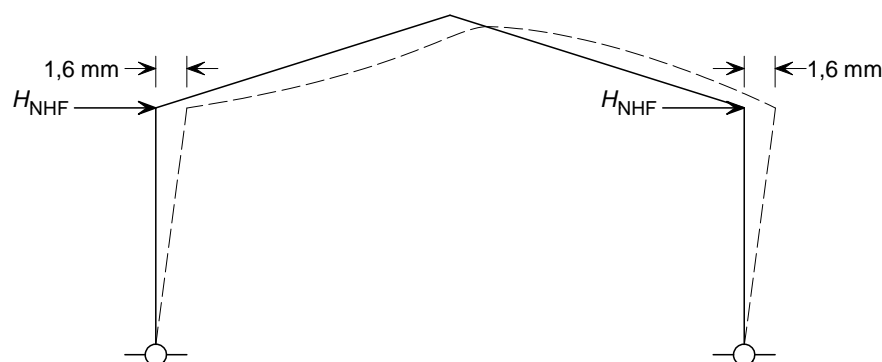

$\alpha_{cr,s,est}$ is calculated as follows:

Appendix B of this document

Appendix B of this document

Title	APPENDIX D Worked Example: Design of portal frame using elastic analysis	6 of 44																						
<p> $\alpha_{cr,s,est} = 0,8 \left\{ 1 - \left(\frac{N_{R,Ed}}{N_{R,cr}} \right)_{\max} \right\} \left\{ \frac{1}{200} \frac{h}{\delta_{NHF}} \right\}$ $= 0,8 \left\{ 1 - \left(\frac{130}{772} \right) \right\} \left\{ \frac{1}{200} \frac{6000}{1,6} \right\} = 12,5$ </p> <p>Thus $\alpha_{cr,est} = \alpha_{cr,s,est} = 12,5 > 10$</p> <p>First order elastic analysis may be used and second order effects do not need to be allowed for.</p> <h2>6. Frame imperfections</h2> <p>The global initial sway imperfection may be determined from</p> $\phi = \phi_0 \alpha_h \alpha_m$ $\phi_0 = 1/200$ $\alpha_h = \frac{2}{\sqrt{h}} = \frac{2}{\sqrt{6,0}} = 0,82$ $\alpha_m = \sqrt{0,5 \left(1 + \frac{1}{m} \right)} = 0,87 = \sqrt{0,5 \left(1 + \frac{1}{2} \right)} = 0,87$ $m = 2 \text{ (number of columns)}$ $\phi = \frac{1}{200} \times 0,82 \times 0,87 = 3,56 \times 10^{-3}$ <p>Initial sway imperfections may be considered in two ways:</p> <ul style="list-style-type: none"> • By modeling the frame out of plumb • By applying equivalent horizontal forces (EHF). <p>Applying equivalent horizontal forces is the preferred option and the method that is used in this worked example. The equivalent horizontal forces are calculated as:</p> $H_{EHF} = \phi V_{Ed}$ <p>However sway imperfections may be disregarded where $H_{Ed} \geq 0,15 V_{Ed}$.</p> <p>Table 1 shows the total reactions for the structure to determine H_{Ed} and V_{Ed}.</p> <p>Table 1 Vertical and horizontal reactions</p> <table border="1" data-bbox="193 1749 1182 1899"> <thead> <tr> <th rowspan="2"></th> <th colspan="2">Left column (kN)</th> <th colspan="2">Right column (kN)</th> <th colspan="2">Total reaction (kN)</th> <th rowspan="2">0,15 VEd (kN)</th> </tr> <tr> <th>H_{Ed}</th> <th>V_{Ed}</th> <th>H_{Ed}</th> <th>V_{Ed}</th> <th>H_{Ed}</th> <th>V_{Ed}</th> </tr> </thead> <tbody> <tr> <td>Reactions</td> <td>116</td> <td>168</td> <td>-116</td> <td>168</td> <td>0</td> <td>336</td> <td>50</td> </tr> </tbody> </table> <p> $H_{Ed} = 0 < 0,15 V_{Ed}$ </p> <p>Therefore the initial sway imperfections have to be taken into account.</p>			Left column (kN)		Right column (kN)		Total reaction (kN)		0,15 VEd (kN)	H_{Ed}	V_{Ed}	H_{Ed}	V_{Ed}	H_{Ed}	V_{Ed}	Reactions	116	168	-116	168	0	336	50	<p>Appendix B of this document</p> <p>Section 2.2 of this document</p> <p>EN 1993-1-1 §5.3.2</p> <p>EN 1993-1-1 §5.3.2(4)</p>
	Left column (kN)		Right column (kN)		Total reaction (kN)		0,15 VEd (kN)																	
	H_{Ed}	V_{Ed}	H_{Ed}	V_{Ed}	H_{Ed}	V_{Ed}																		
Reactions	116	168	-116	168	0	336	50																	

Title	APPENDIX D Worked Example: Design of portal frame using elastic analysis	7 of 44
<p>The equivalent horizontal forces:</p> $H_{EHF} = \phi V_{Ed,column} = 3,56 \times 10^{-3} \times 168 = 0,60 \text{ kN}$ <p>This force is applied at the top of each column, in combination with the permanent and variable actions.</p> <p>For the ULS analysis, the bases are modeled as pinned. Otherwise the base details and foundation would need to be designed for the resulting moment.</p> <p>The following figure shows the internal forces on the frame subject to the ULS loads including the equivalent horizontal forces.</p>		

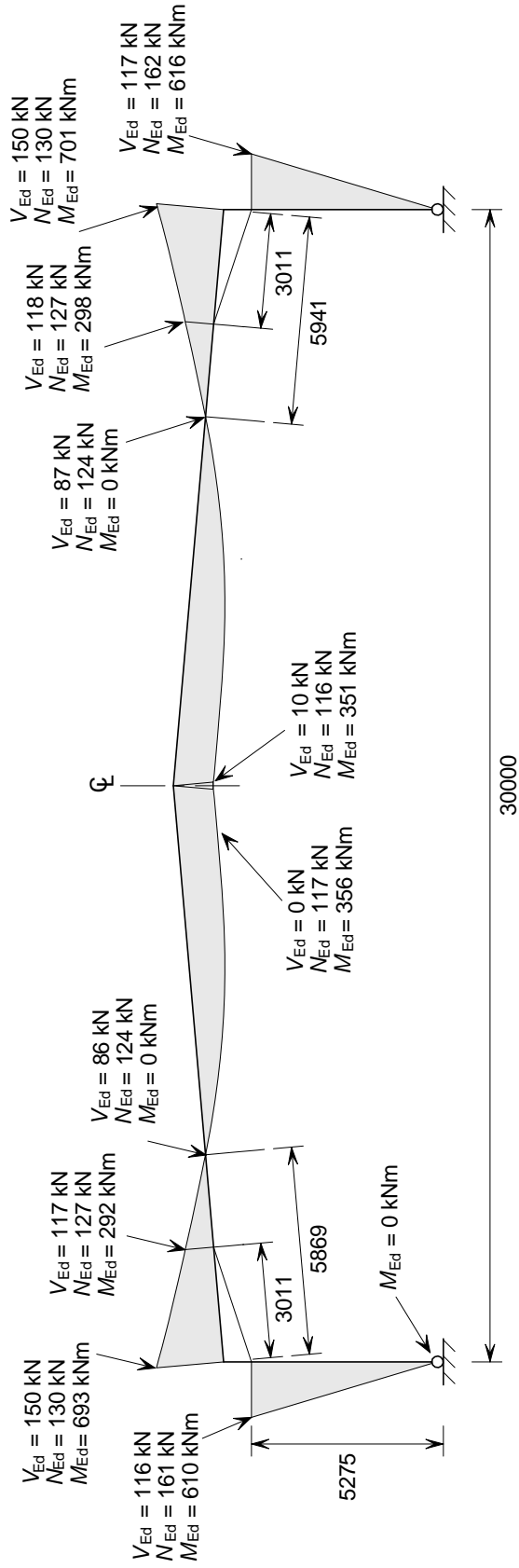

Title	APPENDIX D Worked Example: Design of portal frame using elastic analysis	9 of 44
<p>7. Summary of member verification</p> <p>The cross-section resistance and the buckling resistance are verified for each member. Sections 7.1 and 7.2 provide a summary of the checks carried out for each member of the frame.</p> <p>7.1. Cross-section verification</p> <p>The resistance of the cross-section has to be verified in accordance with Section 6.2 of EN 1993-1-1.</p> <p>The cross-sectional checks carried out in this worked example are:</p> <p>Shear resistance</p> $V_{Ed} \leq V_{pl,Rd} = \frac{A_v (f_y / \sqrt{3})}{\gamma_{M0}}$ <p>EN 1993-1-1 §6.2.6</p> <p>Compression resistance</p> $N_{Ed} \leq N_{c,Rd} = \frac{A f_y}{\gamma_{M0}}$ <p>EN 1993-1-1 §6.2.4</p> <p>Bending moment resistance</p> $M_{Ed} \leq M_{pl,y,Rd} = \frac{W_{pl,y} f_y}{\gamma_{M0}}$ <p>EN 1993-1-1 §6.2.5</p> <p>In addition, bending and shear interaction, as well as bending and axial force interaction must be verified.</p> <p>EN 1993-1-1 §6.2.8 §6.2.9</p> <p>7.2. Buckling verification</p> <p>The rafters and the columns must be verified for out-of-plane buckling between restraints and in plane buckling.</p> <p>The buckling checks due to the interaction of axial force and bending moment are carried out using Expressions 6.61 and 6.62 from EN 1993-1-1.</p> $\frac{N_{Ed}}{\chi_y N_{Rk}} + k_{yy} \frac{M_{y,Ed} + \Delta M_{y,Ed}}{\chi_{LT} \frac{M_{y,Rk}}{\gamma_{M1}}} + k_{yz} \frac{M_{z,Ed} + \Delta M_{z,Ed}}{\frac{M_{z,Rk}}{\gamma_{M1}}} \leq 1,0$ $\frac{N_{Ed}}{\chi_z N_{Rk}} + k_{zy} \frac{M_{y,Ed} + \Delta M_{y,Ed}}{\chi_{LT} \frac{M_{y,Rk}}{\gamma_{M1}}} + k_{zz} \frac{M_{z,Ed} + \Delta M_{z,Ed}}{\frac{M_{z,Rk}}{\gamma_{M1}}} \leq 1,0$ <p>EN 1993-1-1 Expressions (6.61) and (6.62)</p>		

For orthodox single-storey portal frames, these expressions can be simplified as follows:

$$\Delta M_{y,Ed} = 0 \text{ and } \Delta M_{z,Ed} = 0 \text{ for Class 1, Class 2 and Class 3 sections.}$$

$$M_{z,Ed} = 0$$

Therefore expressions (6.61) and (6.62) can be written as:

$$\frac{N_{Ed}}{N_{b,y,Rd}} + k_{yy} \frac{M_{y,Ed}}{M_{b,Rd}} \leq 1,0 \text{ and } \frac{N_{Ed}}{N_{b,z,Rd}} + k_{zy} \frac{M_{y,Ed}}{M_{b,Rd}} \leq 1,0$$

Expression (6.61) is used to verify in-plane buckling, and expression (6.62) is used to verify out-of-plane buckling.

COLUMN: IPE 500, S355

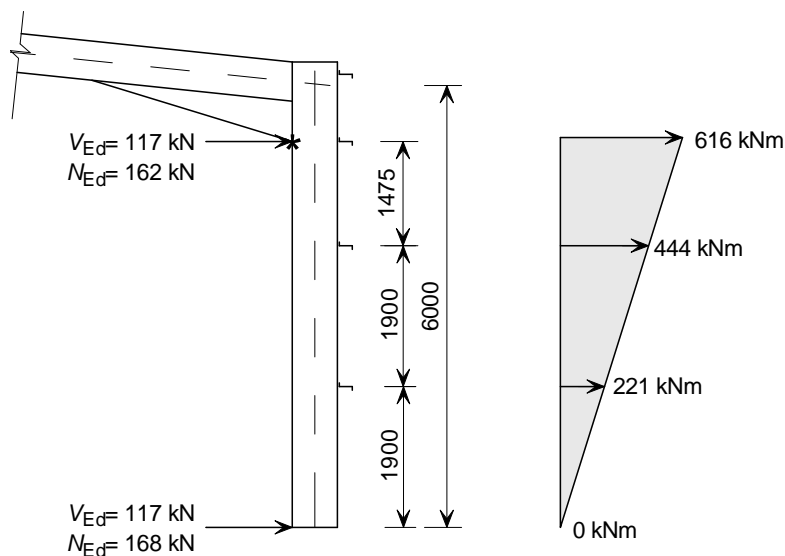

Section properties:

$$h = 500 \text{ mm} \quad A = 11600 \text{ mm}^2$$

$$b = 200 \text{ mm} \quad W_{pl,y} = 2194 \times 10^3 \text{ mm}^3$$

$$t_w = 10,2 \text{ mm} \quad I_y = 48200 \times 10^4 \text{ mm}^4 \quad i_y = 204 \text{ mm}$$

$$t_f = 16 \text{ mm} \quad I_z = 2142 \times 10^4 \text{ mm}^4 \quad i_z = 43,1 \text{ mm}$$

$$r = 21 \text{ mm} \quad I_t = 89,3 \times 10^4 \text{ mm}^4$$

$$h_w = 468 \text{ mm} \quad I_w = 1249 \times 10^9 \text{ mm}^6$$

$$d = 426 \text{ mm}$$

7.3. Cross-section classification

7.3.1. The web

$$\frac{c}{t_w} = \frac{426}{10,2} = 41,8$$

EN 1993-1-1
Table 5.2
(Sheet 1)

Title	APPENDIX D Worked Example: Design of portal frame using elastic analysis	11 of 44
<p> $d_N = \frac{N_{Ed}}{t_w f_y} = \frac{168000}{10,2 \times 355} = 46,4$ $\alpha = \frac{d_w + d_N}{2d_w} = \frac{426 + 46,4}{2 \times 426} = 0,55 > 0,50$ The limit for Class 1 is : $\frac{396 \varepsilon}{13\alpha - 1} = \frac{396 \times 0,81}{13 \times 0,54 - 1} = 53,3$ Then : $\frac{c}{t_w} = 41,8 \leq 53,3$ → The web is class 1. </p> <p>7.3.2. The flange</p> <p> $\frac{c}{t_f} = \frac{73,9}{16} = 4,6$ The limit for Class 1 is : $9 \varepsilon = 9 \times 0,81 = 7,3$ Then : $\frac{c}{t_f} = 4,6 \leq 8,3$ → The flange is Class 1 </p> <p>So the section is Class 1. The verification of the member will be based on the plastic resistance of the cross-section.</p> <p>7.4. Resistance of the cross-section</p> <p>7.4.1. Shear resistance</p> <p>Shear area: $A_v = A - 2bt_f + (t_w + 2r)t_f$ but not less than $\eta h_w t_w$</p> $A_v = 11600 - 2 \times 200 \times 16 + (10,2 + 2 \times 21) \times 16 = 6035 \text{ mm}^2$ <p>Conservatively $\eta = 1,0$. Therefore:</p> $A_v \nless \eta h_w t_w = 1,0 \times 468 \times 10,2 = 4774 \text{ mm}^2$ $\therefore A_v = 6035 \text{ mm}^2$ $V_{pl,Rd} = \frac{A_v (f_y / \sqrt{3})}{\gamma_{M0}} = \frac{6035 (355 / \sqrt{3})}{1,0} \times 10^{-3} = 1237 \text{ kN}$ $V_{Ed} = 117 \text{ kN} < 1237 \text{ kN} \quad \text{OK}$ <p>Bending and shear interaction</p> <p>When shear force and bending moment act simultaneously on a cross-section, the shear force can be ignored if it is smaller than 50% of the plastic shear resistance.</p> $V_{Ed} = 117 \text{ kN} < 0,5 V_{pl,Rd} = 0,5 \times 1237 = 619 \text{ kN}$ <p>Therefore the effect of the shear force on the moment resistance may be neglected.</p>		<p>EN 1993-1-1 Table 5.2 (Sheet 2)</p> <p>EN 1993-1-1 §6.2.6 η from EN 1993-1-1 §6.2.6(3)</p> <p>EN 1993-1-1 §6.2.8</p>

Title	APPENDIX D Worked Example: Design of portal frame using elastic analysis	12 of 44
<p>7.4.2. Compression resistance</p> $N_{c,Rd} = \frac{Af_y}{\gamma_{M0}} = \frac{11600 \times 355}{1,0} \times 10^{-3} = 4118 \text{ kN}$ $N_{Ed} = 168 \text{ kN} \leq N_{c,Rd} = 4118 \text{ kN} \quad \text{OK}$ <p>Bending and axial force interaction</p> <p>When axial force and bending moment act simultaneously on a cross-section, the axial force can be ignored provided the following two conditions are satisfied:</p> $N_{Ed} \leq 0,25 N_{pl,Rd} \quad \text{and} \quad N_{Ed} \leq \frac{0,5 h_w t_w f_y}{\gamma_{M0}}$ $0,25 N_{pl,Rd} = 0,25 \times 4118 = 1030 \text{ kN}$ $\frac{0,5 h_w t_w f_y}{\gamma_{M0}} = \frac{0,5 \times 468 \times 10,2 \times 355}{1,0} \times 10^{-3} = 847 \text{ kN}$ $168 \text{ kN} < 1030 \text{ kN} \text{ and } 847 \text{ kN}, \quad \text{OK}$ <p>Therefore the effect of the axial force on the moment resistance may be neglected.</p> <p>Bending moment resistance</p> $M_{pl,y,Rd} = \frac{W_{pl} f_y}{\gamma_{M0}} = \frac{2194 \times 10^3 \times 355}{1,0} \times 10^{-6} = 779 \text{ kNm}$ $M_{y,Ed} = 616 \text{ kNm} < 779 \text{ kNm} \quad \text{OK}$ <p>7.5. Out-of-plane buckling</p> <p>The out-of-plane buckling interaction is verified with expression (6.62) in EN 1993-1-1.</p> $\frac{N_{Ed}}{N_{b,z,Rd}} + k_{zy} \frac{M_{y,Ed}}{M_{b,Rd}} \leq 1,0$ <p>This expression should be verified between torsional restraints.</p> <p>If the tension flange is restrained at discrete points between the torsional restraints and the spacing between the restraints to the tension flange is small enough, advantage may be taken of this situation.</p> <p>In order to determine whether or not the spacing between restraints is small enough, Annex BB of EN 1993-1-1 provides an expression to calculate the maximum spacing. If the actual spacing between restraints is smaller than this calculated value, then the methods given in Appendix C of this document may be used to calculate the elastic critical force and the critical moment of the section.</p>		<p>EN 1993-1-1 §6.2.4</p> <p>EN 1993-1-1 §6.2.9</p> <p>EN 1993-1-1 §6.2.5</p>

Title	APPENDIX D Worked Example: Design of portal frame using elastic analysis	13 of 44
<p>Verification of spacing between intermediate restraints</p> <p>In this case the restraint to the tension flange is provided by the siderails. These siderails are spaced at 1900 mm.</p> <p>The limiting spacing as given by Annex BB of EN 1993-1-1 is:</p> $L_m = \frac{38i_z}{\sqrt{\frac{1}{57,4} \left(\frac{N_{Ed}}{A} \right) + \frac{1}{756 C_1^2} \frac{W_{pl,y}^2}{AI_t} \left(\frac{f_y}{235} \right)^2}}$ <p>C_1 is a factor that accounts for the shape of the bending moment diagram. C_1 values for different shapes of bending moment diagrams can be found in Appendix C of this document.</p> <p>For a linear bending moment diagram, C_1 depends on the ratio of the minimum and the maximum bending moments in the segment being considered.</p> <p>The ratios of bending moments for the middle and bottom segments of the column (without considering the haunch) are as follows:</p> $\psi = \frac{222}{444} = 0,50 \rightarrow C_1 = 1,31$ $\psi = \frac{0}{222} = 0 \rightarrow C_1 = 1,77$ <p>$C_1 = 1,31$ is the most onerous case and therefore this is the case that will be analysed.</p> $L_m = \frac{38 \times 43,1}{\sqrt{\frac{1}{57,4} \left(\frac{168 \times 10^3}{11600} \right) + \frac{1}{756 \times 1,31^2} \frac{(2194 \times 10^3)^2}{11600 \times 89,3 \times 10^4} \left(\frac{355}{235} \right)^2}}$ $L_m = 1584 \text{ mm}$ <p>Siderail spacing is 1900 mm > 1584 mm</p> <p>Therefore the normal design procedure must be adopted and advantage may not be taken of the restraints to the tension flange.</p> <p>7.5.2. Whole column (5275 mm)</p> <p>Firstly the whole column is verified. If the flexural buckling, lateral torsional buckling and interaction checks are satisfied for the length of the whole column, no further restraints are required. Otherwise, intermediate torsional restraints will be introduced to the column, or the column size increased.</p> <p>Flexural buckling resistance about the minor axis, $N_{b,z,Rd}$</p> $\frac{h}{b} = \frac{500}{200} = 2,5$ $t_f = 16 \text{ mm}$		<p>EN 1993-1-1 Annex BB §BB.3.1.1</p> <p>Appendix C of this document</p>

Title	APPENDIX D Worked Example: Design of portal frame using elastic analysis	14 of 44
<p>buckling about z-z axis:</p> <p>→ Curve b for hot rolled I sections</p> <p>→ $\alpha_z = 0,34$</p> $\lambda_1 = \pi \sqrt{\frac{E}{f_y}} = \pi \sqrt{\frac{210000}{355}} = 76,4$ $\bar{\lambda}_z = \frac{L_{cr}}{i_z} \frac{1}{\lambda_1} = \frac{5275}{43,1} \times \frac{1}{76,4} = 1,60$ $\phi_z = 0,5 \left[1 + \alpha_z (\bar{\lambda}_z - 0,2) + \bar{\lambda}_z^2 \right]$ $= 0,5 \left[1 + 0,34(1,60 - 0,2) + 1,60^2 \right] = 2,02$ $\chi_z = \frac{1}{\phi_z + \sqrt{\phi_z^2 - \bar{\lambda}_z^2}} = \frac{1}{2,02 + \sqrt{2,02^2 - 1,60^2}} = 0,307$ $N_{b,z,Rd} = \frac{\chi_z A f_y}{\gamma_{M1}} = \frac{0,307 \times 11600 \times 355}{1,0} \times 10^{-3} = 1264 \text{ kN}$ <p>$N_{Ed} = 168 \text{ kN} < 1264 \text{ kN}$ OK</p> <p>Lateral-torsional buckling resistance, $M_{b,Rd}$</p> <p>The lateral-torsional buckling resistance of a member is calculated as a reduction factor, χ_{LT}, multiplied by the section modulus and the yield strength of the section. The reduction factor is calculated as a function of the slenderness, $\bar{\lambda}_{LT}$, which depends on the critical moment of the member. The expression for the critical moment, M_{cr}, is given below. The factor C_1 accounts for the shape of bending moment diagram of the member. Appendix C of this document provides values of C_1 for different shapes of bending moment diagrams. For the case of a linear bending moment diagram, C_1 depends on the ratio of the bending moments at the ends of the member, given as ψ.</p> <p>For the total length of the column (without the haunch):</p> $\psi = \frac{0}{616} = 0 \quad \rightarrow C_1 = 1,77$ $M_{cr} = C_1 \frac{\pi^2 EI_z}{L^2} \sqrt{\frac{I_w}{I_z} + \frac{L^2 GI_t}{\pi^2 EI_z}}$ $= 1,77 \times \frac{\pi^2 \times 210000 \times 2142 \times 10^4}{5275^2}$ $\times \sqrt{\frac{1249 \times 10^9}{2142 \times 10^4} + \frac{5275^2 \times 81000 \times 89,3 \times 10^4}{\pi^2 \times 210000 \times 2142 \times 10^4}}$ $M_{cr} = 909 \times 10^6 \text{ Nmm}$		<p>EN 1993-1-1 Table 6.2 Table 6.1</p> <p>EN 1993-1-1 §6.3.1.3</p> <p>EN 1993-1-1 §6.3.1.2</p> <p>Appendix C of this document</p> <p>Appendix C of this document</p>

Title	APPENDIX D Worked Example: Design of portal frame using elastic analysis	15 of 44
<p>The non dimensional slenderness, $\bar{\lambda}_{LT}$, is calculated as:</p> $\bar{\lambda}_{LT} = \sqrt{\frac{W_y f_y}{M_{cr}}} = \sqrt{\frac{2194 \times 10^3 \times 355}{909 \times 10^6}} = 0,926$ <p>For the calculation of the reduction factor, χ_{LT}, EN 1993-1-1 provides two methods. The general method, applicable to any section, is given in §6.3.2.2. §6.3.2.3 provides a method that can only be used for rolled sections or equivalent welded sections.</p> <p>In this example the second method is used, i.e. §6.3.2.3.</p> $\phi_{LT} = 0,5 \left[1 + \alpha_{LT} (\bar{\lambda}_{LT} - \bar{\lambda}_{LT,0}) + \beta \bar{\lambda}_{LT}^2 \right]$ <p>EN 1993-1-1 recommends the following values:</p> $\bar{\lambda}_{LT,0} = 0,4$ $\beta = 0,75$ <p>The values given in the National Annex may differ. The designer should check the National Annex of the country where the structure is to be built.</p> $\frac{h}{b} = 2,5$ <p>→ Curve c for hot rolled I sections</p> <p>→ $\alpha_{LT} = 0,49$</p> $\phi_{LT} = 0,5 \left[1 + 0,49(0,926 - 0,4) + 0,75 \times 0,926^2 \right] = 0,950$ $\chi_{LT} = \frac{1}{\phi_{LT} + \sqrt{\phi_{LT}^2 - \beta \bar{\lambda}_{LT}^2}}$ $\chi_{LT} = \frac{1}{0,950 + \sqrt{0,950^2 - 0,75 \times 0,926^2}} = 0,685$ $\frac{1}{\bar{\lambda}_{LT}^2} = \frac{1}{0,926^2} = 1,17$ <p>∴ $\chi_{LT} = 0,685$</p> $M_{b,Rd} = \frac{\chi_{LT} W_{pl,y} f_y}{\gamma_{M1}} = \frac{0,685 \times 2194 \times 10^3 \times 355}{1,0} \times 10^{-6} = 534 \text{ kNm}$ <p>$M_{b,Rd} = 616 \text{ kNm} \not\leq 534 \text{ kNm}$ Fails</p> <p>Since the check for lateral torsional buckling resistance alone fails, the interaction of axial force and bending moment is not carried out.</p> <p>It is necessary to introduce a torsional restraint between the haunch and the base, as shown in the following figure. The bending moment is greater at the top of the column and therefore the restraint is placed closer to the maximum bending moment, rather than in the middle of the column.</p>		<p>EN 1993-1-1 §6.3.2.2</p> <p>EN 1993-1-1 §6.3.2.3</p> <p>EN 1993-1-1 Table 6.3 Table 6.5</p> <p>EN 1993-1-1 §6.3.2.3</p>

The restraint must be at a side rail position, since bracing from the side rail to the inner flange is used to provide the torsional restraint.

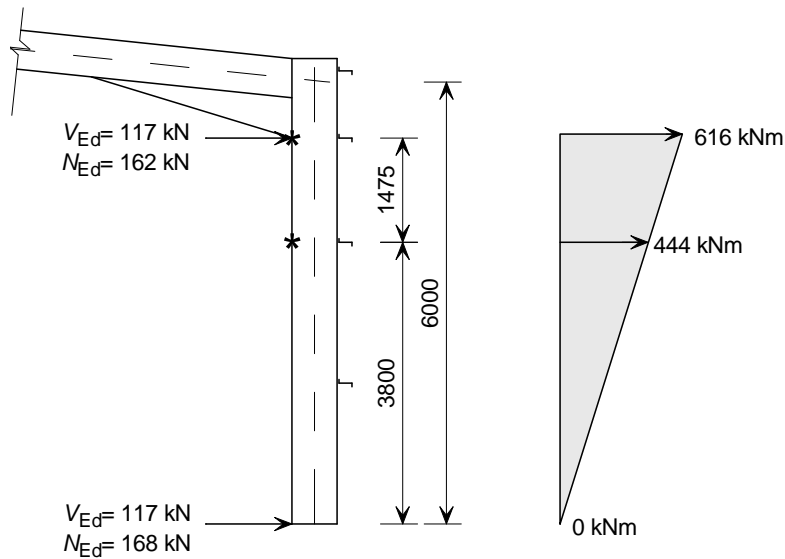

7.5.3. Upper segment (1475 mm)

As previously, the flexural buckling and the lateral torsional buckling checks are carried out separately before proceeding to verify the interaction between the two.

Flexural buckling resistance about the minor axis, $N_{b,z,Rd}$

$$\frac{h}{b} = \frac{500}{200} = 2,5$$

$$t_f = 16 \text{ mm}$$

buckling about z-z axis:

→ Curve **b** for hot rolled I sections

$$\rightarrow \alpha_z = 0,34$$

$$\lambda_1 = \pi \sqrt{\frac{E}{f_y}} = \pi \sqrt{\frac{210000}{355}} = 76,4$$

$$\bar{\lambda}_z = \frac{L_{cr}}{i_z} \frac{1}{\lambda_1} = \frac{1475}{43,1} \times \frac{1}{76,4} = 0,448$$

$$\begin{aligned} \phi_z &= 0,5 \left[1 + \alpha_z (\bar{\lambda}_z - 0,2) + \bar{\lambda}_z^2 \right] \\ &= 0,5 \left[1 + 0,34(0,448 - 0,2) + 0,448^2 \right] = 0,643 \end{aligned}$$

$$\chi_z = \frac{1}{\phi_z + \sqrt{\phi_z^2 - \bar{\lambda}_z^2}} = \frac{1}{0,643 + \sqrt{0,643^2 - 0,448^2}} = 0,906$$

$$\chi_z = 0,906$$

EN 1993-1-1
Table 6.2
Table 6.1

EN 1993-1-1
§6.3.1.3

EN 1993-1-1
§6.3.1.2

$$N_{b,z,Rd} = \frac{\chi_z A f_y}{\gamma_{M1}} = \frac{0,906 \times 11600 \times 355}{1,0} \times 10^{-3} = 3731 \text{ kN}$$

$$N_{Ed} = 168 \text{ kN} < 3731 \text{ kN} \quad \text{OK}$$

Lateral-torsional buckling resistance, $M_{b,Rd}$

As previously the factor C_1 needs to be calculated in order to determine the critical moment of the member.

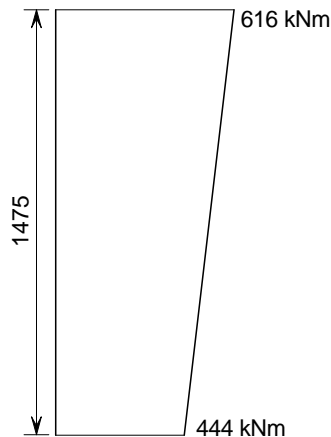

$$\psi = \frac{444}{616} = 0,721 \quad \rightarrow C_1 = 1,16$$

$$M_{cr} = C_1 \frac{\pi^2 EI_z}{L^2} \sqrt{\frac{I_w}{I_z} + \frac{L^2 GI_t}{\pi^2 EI_z}}$$

$$= 1,16 \times \frac{\pi^2 \times 210000 \times 2142 \times 10^4}{1475^2}$$

$$\times \sqrt{\frac{1249 \times 10^9}{2142 \times 10^4} + \frac{1475^2 \times 81000 \times 89,3 \times 10^4}{\pi^2 \times 210000 \times 2142 \times 10^4}}$$

$$M_{cr} = 5887 \times 10^6 \text{ Nmm}$$

$$\bar{\lambda}_{LT} = \sqrt{\frac{W_y f_y}{M_{cr}}} = \sqrt{\frac{2194 \times 10^3 \times 355}{5887 \times 10^6}} = 0,364$$

For hot rolled sections

$$\phi_{LT} = 0,5 \left[1 + \alpha_{LT} (\bar{\lambda}_{LT} - \bar{\lambda}_{LT,0}) + \beta \bar{\lambda}_{LT}^2 \right]$$

$$\bar{\lambda}_{LT,0} = 0,4$$

$$\beta = 0,75$$

As previously:

→ Curve c for hot rolled I sections

$$\rightarrow \alpha_{LT} = 0,49$$

Appendix C of
this document

Appendix C of
this document

EN 1993-1-1
§6.3.2.2

EN 1993-1-1
§6.3.2.3

EN 1993-1-1
Table 6.3
Table 6.5

Title	APPENDIX D Worked Example: Design of portal frame using elastic analysis	18 of 44
<p> $\phi_{LT} = 0,5 \left[1 + 0,49(0,364 - 0,4) + 0,75 \times 0,364^2 \right] = 0,541$ $\chi_{LT} = \frac{1}{\phi_{LT} + \sqrt{\phi_{LT}^2 - \beta \bar{\lambda}_{LT}^2}}$ $\chi_{LT} = \frac{1}{0,541 + \sqrt{0,541^2 - 0,75 \times 0,364^2}} = 1,02$ χ_{LT} cannot be greater than 1.0, therefore: $\chi_{LT} = 1,0$ $M_{b,Rd} = \frac{\chi_{LT} W_{pl,y} f_y}{\gamma_{M1}} = \frac{1,0 \times 2194 \times 10^3 \times 355}{1,0} \times 10^{-6} = 779 \text{ kNm}$ $M_{Ed} = 616 \text{ kNm} < 779 \text{ kNm} \quad \text{OK}$ </p> <p>Interaction of axial force and bending moment – out-of-plane buckling</p> <p>Out-of-plane buckling due to the interaction of axial force and bending moment is verified by satisfying the following expression:</p> $\frac{N_{Ed}}{N_{b,z,Rd}} + k_{zy} \frac{M_{y,Ed}}{M_{b,Rd}} \leq 1,0$ <p>For $\bar{\lambda}_z \geq 0,4$, the interaction factor, k_{zy} is calculated as:</p> $k_{zy} = \max \left[\left(1 - \frac{0,1 \bar{\lambda}_z}{(C_{mLT} - 0,25)} \frac{N_{Ed}}{N_{b,Rd,z}} \right); \left(1 - \frac{0,1}{(C_{mLT} - 0,25)} \frac{N_{Ed}}{N_{b,Rd,z}} \right) \right]$ $C_{mLT} = 0,6 + 0,4\psi$ $\psi = \frac{444}{616} = 0,721$ $C_{mLT} = 0,6 + 0,4 \times 0,721 = 0,888 > 0,4$ $\therefore C_{mLT} = 0,888$ $k_{zy} = \max \left[\left(1 - \frac{0,1 \times 0,448}{(0,888 - 0,25)} \frac{168}{3731} \right); \left(1 - \frac{0,1}{(0,888 - 0,25)} \frac{168}{3731} \right) \right]$ $k_{zy} = \max (0,996; 0,993) = 0,996$ $\frac{N_{Ed}}{N_{b,z,Rd}} + k_{zy} \frac{M_{y,Ed}}{M_{b,Rd}} = \frac{168}{3731} + 0,996 \frac{616}{779} = 0,832 < 1,0 \quad \text{OK}$		<p>EN 1993-1-1 §6.3.2.3</p> <p>EN 1993-1-1 §6.3.3(4)</p> <p>EN 1993-1-1 Annex B Table B.2</p> <p>EN 1993-1-1 Annex B Table B.3</p>
<p>7.5.4. Lower segment (3800 mm)</p> <p>As previously the flexural buckling resistance and the lateral-torsional buckling resistance are checked individually and then the interaction between the two is verified by using interaction Expression 6.62.</p>		

Flexural buckling resistance about the minor axis, $N_{b,z,Rd}$

As previously:

→ Curve **b** for hot rolled I sections

→ $\alpha_z = 0,34$

$$\lambda_1 = \pi \sqrt{\frac{E}{f_y}} = \pi \sqrt{\frac{210000}{355}} = 76,4$$

$$\bar{\lambda}_z = \frac{L_{cr}}{i_z} \frac{1}{\lambda_1} = \frac{3800}{43,1} \times \frac{1}{76,4} = 1,15$$

$$\phi_z = 0,5 \left[1 + \alpha_z (\bar{\lambda}_z - 0,2) + \bar{\lambda}_z^2 \right]$$

$$\phi_z = 0,5 \left[1 + 0,34(1,15 - 0,2) + 1,15^2 \right] = 1,32$$

$$\chi_z = \frac{1}{\phi_z + \sqrt{\phi_z^2 - \bar{\lambda}_z^2}} = \frac{1}{1,32 + \sqrt{1,32^2 - 1,15^2}} = 0,508$$

$$N_{b,z,Rd} = \frac{\chi_z A f_y}{\gamma_{M1}} = \frac{0,508 \times 11600 \times 355}{1,0} \times 10^{-3} = 2092 \text{ kN}$$

$$N_{Ed} = 168 \text{ kN} < 2092 \text{ kN} \quad \text{OK}$$

Lateral-torsional buckling resistance, $M_{b,Rd}$

As previously the C_1 factor needs to be calculated in order to determine the critical moment of the member.

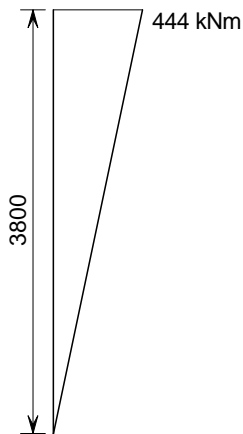

$$\psi = \frac{0}{444} = 0 \quad \rightarrow C_1 = 1,77$$

EN 1993-1-1
Table 6.1
Table 6.2

EN 1993-1-1
§6.3.1.3

EN 1993-1-1
§6.3.1.2

Appendix C of
this document

Title	APPENDIX D Worked Example: Design of portal frame using elastic analysis	20 of 44
$M_{cr} = C_1 \frac{\pi^2 EI_z}{L^2} \sqrt{\frac{I_w}{I_z} + \frac{L^2 GI_t}{\pi^2 EI_z}}$ $= 1,77 \times \frac{\pi^2 \times 210000 \times 2142 \times 10^4}{3800^2}$ $\times \sqrt{\frac{1249 \times 10^9}{2142 \times 10^4} + \frac{3800^2 \times 81000 \times 89,3 \times 10^4}{\pi^2 \times 210000 \times 2142 \times 10^4}}$ $M_{cr} = 1556 \times 106 \text{ Nmm}$ $\bar{\lambda}_{LT} = \sqrt{\frac{W_y f_y}{M_{cr}}} = \sqrt{\frac{2194 \times 10^3 \times 355}{1556 \times 10^6}} = 0,708$ <p>For hot rolled sections</p> $\phi_{LT} = 0,5 \left[1 + \alpha_{LT} (\bar{\lambda}_{LT} - \bar{\lambda}_{LT,0}) + \beta \bar{\lambda}_{LT}^2 \right]$ $\bar{\lambda}_{LT,0} = 0,4 \text{ and } \beta = 0,75$ <p>As previously:</p> <p>→ Curve c for hot rolled I sections</p> <p>→ $\alpha_{LT} = 0,49$</p> $\phi_{LT} = 0,5 \left[1 + 0,49(0,708 - 0,4) + 0,75 \times 0,708^2 \right] = 0,763$ $\chi_{LT} = \frac{1}{\phi_{LT} + \sqrt{\phi_{LT}^2 - \beta \bar{\lambda}_{LT}^2}}$ $\chi_{LT} = \frac{1}{0,763 + \sqrt{0,763^2 - 0,75 \times 0,708^2}} = 0,822$ $\frac{1}{\bar{\lambda}_{LT}^2} = \frac{1}{0,708^2} = 1,99$ <p>∴ $\chi_{LT} = 0,822$</p> $M_{b,Rd} = \frac{\chi_{LT} W_{pl,y} f_y}{\gamma_{M1}} = \frac{0,822 \times 2194 \times 10^3 \times 355}{1,0} \times 10^{-6} = 640 \text{ kNm}$ $M_{Ed} = 616 \text{ kNm} < 640 \text{ kNm} \quad \text{OK}$ <p>Interaction of axial force and bending moment – out-of-plane buckling</p> <p>Out-of-plane buckling due to the interaction of axial force and bending moment is verified by satisfying the following expression:</p> $\frac{N_{Ed}}{N_{b,z,Rd}} + k_{zy} \frac{M_{y,Ed}}{M_{b,Rd}} \leq 1,0$		<p>Appendix C of this document</p> <p>EN 1993-1-1 §6.3.2.2</p> <p>EN 1993-1-1 §6.3.2.3</p> <p>EN 1993-1-1 Table 6.3 Table 6.5</p> <p>EN 1993-1-1 §6.3.2.3</p> <p>EN 1993-1-1 §6.3.3(4)</p>

For $\bar{\lambda}_z \geq 0.4$, the interaction factor, k_{zy} is calculated as:

$$k_{zy} = \max \left[\left(1 - \frac{0,1 \bar{\lambda}_z}{(C_{mLT} - 0,25)} \frac{N_{Ed}}{N_{b,Rd,z}} \right); \left(1 - \frac{0,1}{(C_{mLT} - 0,25)} \frac{N_{Ed}}{N_{b,Rd,z}} \right) \right]$$

$$C_{mLT} = 0,6 + 0,4\psi$$

$$\psi = \frac{0}{444} = 0$$

$$C_{mLT} = 0,6 + 0,4\psi = 0,6 + 0,4 \times 0 = 0,6 > 0,4$$

$$\therefore C_{mLT} = 0,6$$

$$k_{zy} = \max \left[\left(1 - \frac{0,1 \times 1,15}{(0,6 - 0,25)} \frac{168}{2092} \right); \left(1 - \frac{0,1}{(0,6 - 0,25)} \frac{168}{2092} \right) \right]$$

$$k_{zy} = \max (0,974; 0,977) = 0,977$$

$$\frac{N_{Ed}}{N_{b,z,Rd}} + k_{zy} \frac{M_{y,Ed}}{M_{b,Rd}} = \frac{168}{2092} + 0,977 \frac{444}{640} = 0,758 < 1,0 \quad \text{OK}$$

EN 1993-1-1
Annex B
Table B.3

EN 1993-1-1
Annex B
Table B.2

7.6. In-plane buckling

The in-plane buckling interaction is verified with expression (6.61) in EN 1993-1-1.

$$\frac{N_{Ed}}{N_{b,y,Rd}} + k_{yy} \frac{M_{y,Ed}}{M_{b,Rd}} \leq 1,0$$

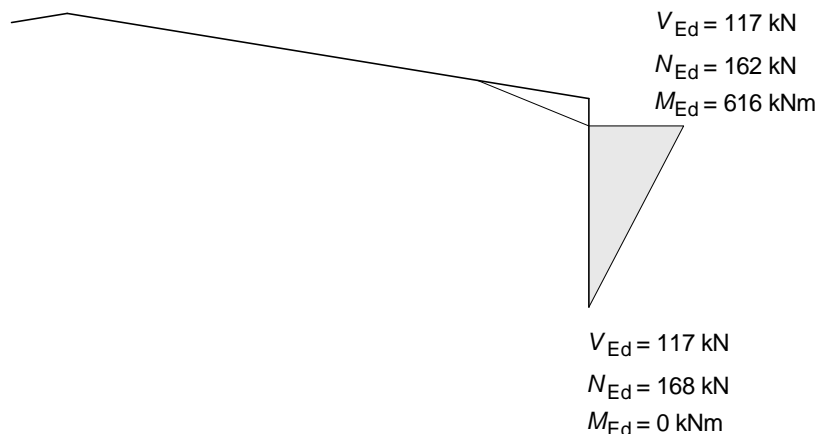

The maximum design values of either column occur on the right hand column (considering EHF applied from left to right) and are as follows:

$$M_{Ed} = 616 \text{ kNm}$$

$$N_{Ed} = 168 \text{ kN}$$

Title	APPENDIX D Worked Example: Design of portal frame using elastic analysis	22 of 44	
<p>Firstly individual checks are carried out for flexural buckling alone and lateral-torsional buckling alone. Then the interaction expression for in-plane buckling is applied to verify that the combination of axial force and bending moment does not cause excessive buckling on the columns.</p> <p>7.6.1. Flexural buckling resistance about the mayor axis, $N_{b,y,Rd}$</p> $\frac{h}{b} = \frac{500}{200} = 2,5$ $t_f = 16 \text{ mm}$ <p>buckling about y-y axis:</p> <p>→ Curve a for hot rolled I sections</p> <p>→ $\alpha_y = 0,21$</p> <p>The buckling length is the system length, which is the distance between nodes (i.e. the length of the column), $L = 6000 \text{ mm}$.</p> $\lambda_1 = \pi \sqrt{\frac{E}{f_y}} = \pi \sqrt{\frac{210000}{355}} = 76,4$ $\bar{\lambda}_y = \frac{L_{cr}}{i_y} \frac{1}{\lambda_1} = \frac{6000}{204} \times \frac{1}{76,4} = 0,385$ $\phi_y = 0,5 \left[1 + \alpha_y (\bar{\lambda}_y - 0,2) + \bar{\lambda}_y^2 \right]$ $= 0,5 \left[1 + 0,21(0,385 - 0,2) + 0,385^2 \right] = 0,594$ $\chi_y = \frac{1}{\phi_y + \sqrt{\phi_y^2 - \bar{\lambda}_y^2}} = \frac{1}{0,594 + \sqrt{0,594^2 - 0,385^2}} = 0,956$ $N_{b,y,Rd} = \frac{\chi_y A f_y}{\gamma_{M1}} = \frac{0,956 \times 11600 \times 355}{1,0} \times 10^{-3} = 3937 \text{ kN}$ $N_{Ed} = 168 \text{ kN} < 3937 \text{ kN} \quad \text{OK}$ <p>7.6.2. Lateral-torsional buckling resistance, $M_{b,Rd}$</p> <p>$M_{b,Rd}$ is the least buckling moment resistance of those calculated previously.</p> $M_{b,Rd} = \min(779; 640)$ $M_{b,Rd} = 640 \text{ kNm}$ <p>7.6.3. Interaction of axial force and bending moment – in-plane buckling</p> <p>In-plane buckling due to the interaction of axial force and bending moment is verified by satisfying the following expression:</p> $\frac{N_{Ed}}{N_{b,y,Rd}} + k_{yy} \frac{M_{y,Ed}}{M_{b,Rd}} \leq 1,0$			<p>EN 1993-1-1 Table 6.2 Table 6.1</p> <p>EN 1993-1-1 §6.3.1.3</p> <p>EN 1993-1-1 §6.3.1.2</p> <p>EN 1993-1-1 §6.3.1.2</p>

For C_{my} , the relevant braced points are the torsional restraints at the end of the member.

The interaction factor, k_{yy} , is calculated as follows:

$$k_{yy} = \min \left[C_{my} \left(1 + (\bar{\lambda}_y - 0,2) \frac{N_{Ed}}{N_{b,y,Rd}} \right); C_{my} \left(1 + 0,8 \frac{N_{Ed}}{N_{b,y,Rd}} \right) \right]$$

From table B.3, C_{my} is:

$$C_{my} = 0,6 + 0,4\psi \geq 0,4$$

$$\psi = 0$$

$$C_{my} = 0,6 + 0,4 \times 0 = 0,6$$

$$k_{yy} = \min \left[0,6 \left(1 + (0,385 - 0,2) \frac{168}{3937} \right); 0,6 \left(1 + 0,8 \frac{168}{3937} \right) \right]$$

$$= \min(0,605; 0,620) = 0,605$$

$$\frac{N_{Ed}}{N_{b,y,Rd}} + k_{yy} \frac{M_{y,Ed}}{M_{b,Rd}} = \frac{168}{3937} + 0,605 \frac{616}{640} = 0,625 < 1,0 \quad \text{OK}$$

Validity of column section

In Section 7.4 it has been demonstrated that the cross-sectional resistance of the section is greater than the applied forces.

The out-of-plane and in-plane buckling checks have been verified in Sections 7.5 and 7.6 for the appropriate choice of restraints along the column.

Therefore it is concluded that the IPE 450 section in S355 steel is appropriate for use as columns in this portal frame.

Rafter: IPE 450

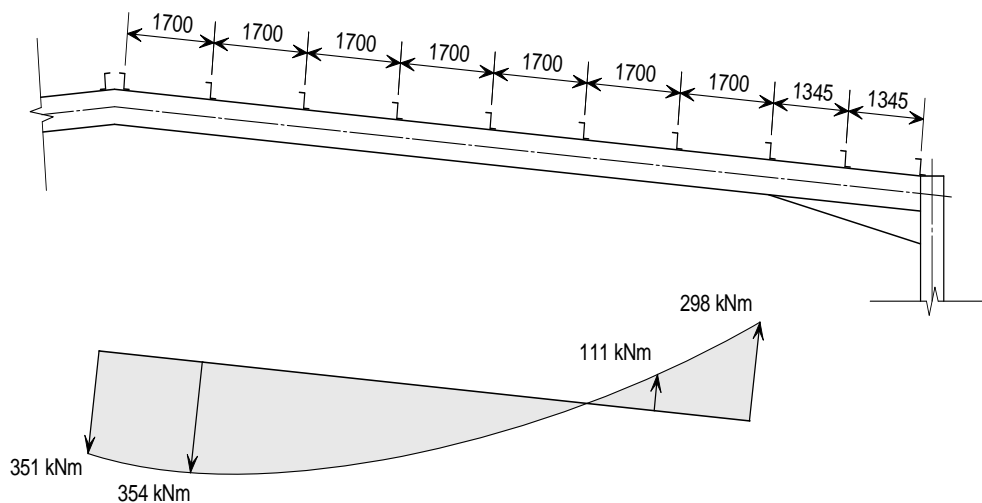

Title	APPENDIX D Worked Example: Design of portal frame using elastic analysis	24 of 44
<p> $V_{Ed} = 118 \text{ kN}$ (maximum value) $N_{Ed} = 127 \text{ kN}$ (maximum value) $M_{Ed} = 356 \text{ kNm}$ (maximum value) </p> <p>Section properties</p> <p> $h = 450 \text{ mm}$ $A = 9880 \text{ mm}^2$ $b = 190 \text{ mm}$ $W_{pl,y} = 1702 \times 10^3 \text{ mm}^3$ $t_w = 9,4 \text{ mm}$ $I_y = 33740 \times 10^4 \text{ mm}^4$ $i_y = 185 \text{ mm}$ $t_f = 14,6 \text{ mm}$ $I_z = 1676 \times 10^4 \text{ mm}^4$ $i_z = 41,2 \text{ mm}$ $r = 21 \text{ mm}$ $I_t = 66,9 \times 10^4 \text{ mm}^4$ $h_w = 420,8 \text{ mm}$ $I_w = 791 \times 10^9 \text{ mm}^6$ $d = 378,8 \text{ mm}$ </p> <p>7.7. Cross-section classification</p> <p>7.7.1. The web</p> $\frac{c}{t_w} = \frac{378,8}{9,4} = 40,3$ $d_N = \frac{N_{Ed}}{t_w f_y} = \frac{127000}{9,4 \times 355} = 38$ $\alpha = \frac{d_w + d_N}{2d_w} = \frac{378,8 + 38}{2 \times 378,8} = 0,55 > 0,50$ <p>The limit for Class 1 is : $\frac{396 \varepsilon}{13\alpha - 1} = \frac{396 \times 0,81}{13 \times 0,55 - 1} = 52,1$</p> <p>Then : $\frac{c}{t_w} = 40,3 < 52,1$</p> <p>→ The web is class 1.</p> <p>7.7.2. The flange</p> $\frac{c}{t_f} = \frac{69,3}{14,6} = 4,7$ <p>The limit for Class 1 is : $9 \varepsilon = 9 \times 0,81 = 7,3$</p> <p>Then : $\frac{c}{t_f} = 4,7 < 7,3$</p> <p>→ The flange is Class 1</p> <p>Therefore, the section is Class 1. The verification of the member will be based on the plastic resistance of the cross-section.</p>		
		EN 1993-1-1 Table 5.2 (Sheet 1)
		EN 1993-1-1 Table 5.2 (Sheet 2)

Title	APPENDIX D Worked Example: Design of portal frame using elastic analysis	25 of 44
<p>7.8. Resistance of the cross-section</p> <p>7.8.1. Shear resistance</p> <p>Shear area : $A_v = A - 2bt_f + (t_w + 2r)t_f$ but not less than $\eta h_w t_w$</p> $A_v = 9880 - 2 \times 190 \times 14,6 + (9,4 + 2 \times 21) \times 14,6 = 5082 \text{ mm}^2$ $\eta h_w t_w = 1,0 \times 420,8 \times 9,4 = 3956 \text{ mm}^2$ $\therefore A_v = 5082 \text{ mm}^2$ $V_{pl,Rd} = \frac{A_v (f_y / \sqrt{3})}{\gamma_{M0}} = \frac{5082 (355 / \sqrt{3})}{1,0} \times 10^{-3} = 1042 \text{ kN}$ <p>$V_{Ed} = 118 \text{ kN} < 1042 \text{ kN}$ OK</p> <p>Bending and shear interaction</p> <p>When shear force and bending moment act simultaneously on a cross-section, the shear force can be ignored if it is smaller than 50% of the plastic shear resistance of the cross-section.</p> <p>$V_{Ed} = 118 \text{ kN} < 0,5 V_{pl,Rd} = 521 \text{ kN}$ OK</p> <p>Therefore the effect of the shear force on the moment resistance may be neglected.</p> <p>7.8.2. Compression resistance</p> $N_{c,Rd} = \frac{A f_y}{\gamma_{M0}} = \frac{9880 \times 355}{1,0} \times 10^{-3} = 3507 \text{ kN}$ <p>$N_{Ed} = 127 \text{ kN} < 3507 \text{ kN}$ OK</p> <p>Bending and axial force interaction</p> <p>When axial force and bending moment act simultaneously on a cross-section, the axial force can be ignored provided the following two conditions are satisfied:</p> $N_{Ed} < 0,25 N_{pl,Rd} \quad \text{and} \quad N_{Ed} < \frac{0,5 h_w t_w f_y}{\gamma_{M0}}$ <p>$0,25 N_{pl,Rd} = 0,25 \times 3507 = 877 \text{ kN}$</p> <p>And</p> $\frac{0,5 h_w t_w f_y}{\gamma_{M0}} = \frac{0,5 \times 420,8 \times 9,4 \times 355}{1,0} \times 10^{-3} = 702 \text{ kN}$ <p>$127 \text{ kN} < 887 \text{ kN}$ and 702 kN OK</p> <p>Therefore the effect of the axial force on the moment resistance may be neglected.</p>		<p>EN 1993-1-1 §6.2.6(3)</p> <p>η from EN 1993-1-1 §6.2.6(3)</p> <p>EN 1993-1-1 §6.2.6(3)</p> <p>EN 1993-1-1 §6.2.8</p> <p>EN 1993-1-1 §6.2.4</p> <p>EN 1993-1-1 §6.2.9</p>

7.8.3. Bending moment resistance

$$M_{pl,y,Rd} = \frac{W_{pl,y} f_y}{\gamma_{M0}} = \frac{1702 \times 10^3 \times 355}{1,0} \times 10^{-6} = 604 \text{ kNm}$$

$$M_{y,Ed} = 356 \text{ kNm} < 604 \text{ kNm} \quad \text{OK}$$

7.9. Out-of-plane buckling

The out-of-plane buckling interaction is verified with expression (6.62) from EN 1993-1-1

$$\frac{N_{Ed}}{N_{z,b,Rd}} + k_{zy} \frac{M_{y,Ed}}{M_{b,Rd}} \leq 1,0$$

The rafter should be verified between torsional restraints. If advantage is taken of intermediate restraints to the tension flange, the spacing of the intermediate restraints must also be verified.

7.9.1. Mid-span region

The purlin spacing in this region is 1700 mm.

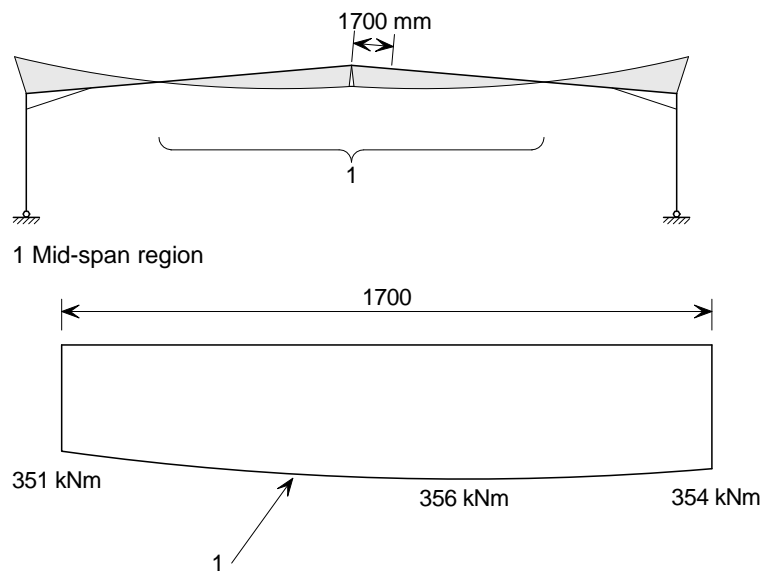

1 Mid-span region

1: Bending moment

Flexural buckling resistance about minor axis bending, $N_{b,z,Rd}$

$$\frac{h}{b} = \frac{450}{190} = 2,37$$

$$t_f = 14,6 \text{ mm}$$

buckling about z-z axis

→ Curve **b** for hot rolled I sections

$$\rightarrow \alpha_z = 0,34$$

EN 1993-1-1
§6.2.5

EN 1993-1-1
Table 6.1
Table 6.2

Title	APPENDIX D Worked Example: Design of portal frame using elastic analysis	27 of 44
$\lambda_1 = \pi \sqrt{\frac{E}{f_y}} = \pi \sqrt{\frac{210000}{355}} = 76,4$ $\bar{\lambda}_z = \frac{L_{cr}}{i_z} \frac{1}{\lambda_1} = \frac{1700}{41,2} \times \frac{1}{76,4} = 0,540$ $\phi_z = 0,5 \left[1 + \alpha_z (\bar{\lambda}_z - 0,2) + \bar{\lambda}_z^2 \right]$ $\phi_z = 0,5 \left[1 + 0,34(0,540 - 0,2) + 0,540^2 \right] = 0,704$ $\chi_z = \frac{1}{\phi_z + \sqrt{\phi_z^2 - \bar{\lambda}_z^2}} = \frac{1}{0,704 + \sqrt{0,704^2 - 0,540^2}} = 0,865$ $N_{b,z,Rd} = \frac{\chi_z A f_y}{\gamma_{M1}} = \frac{0,865 \times 9880 \times 355}{1,0} \times 10^{-3} = 3034 \text{ kN}$ $N_{Ed} = 127 \text{ kN} < 3034 \text{ kN} \quad \text{OK}$ <p>Lateral-torsional buckling resistance for bending, $M_{b,Rd}$</p> <p>In this zone, lateral-torsional buckling is checked between restraints, which are the purlins. For equally spaced purlins, the critical length is at the point of maximum bending moment.</p> <p>In order to determine the critical moment of the rafter, the C_1 factor takes account of the shape of the bending moment diagram.</p> <p>In this case the bending moment diagram is nearly constant along the segment in consideration, so $\psi \approx 1,0$. Therefore:</p> <p>→ $C_1 = 1,0$</p> $M_{cr} = C_1 \frac{\pi^2 EI_z}{L^2} \sqrt{\frac{I_w}{I_z} + \frac{L^2 GI_t}{\pi^2 EI_z}}$ $= 1,0 \times \frac{\pi^2 \times 210000 \times 1676 \times 10^4}{1700^2} \times \sqrt{\frac{791 \times 10^9}{1676 \times 10^4} + \frac{1700^2 \times 81000 \times 66,9 \times 10^4}{\pi^2 \times 210000 \times 1676 \times 10^4}}$ $M_{cr} = 2733 \times 10^6 \text{ Nmm}$ $\bar{\lambda}_{LT} = \sqrt{\frac{W_{pl,y} f_y}{M_{cr}}} = \sqrt{\frac{1702 \times 10^3 \times 355}{2733 \times 10^6}} = 0,470$ $\phi_{LT} = 0,5 \left[1 + \alpha_{LT} (\bar{\lambda}_{LT} - \bar{\lambda}_{LT,0}) + \beta \bar{\lambda}_{LT}^2 \right]$		<p>EN 1993-1-1 §6.3.1.3</p> <p>EN 1993-1-1 §6.3.1.2</p> <p>Appendix C of this document</p> <p>Appendix C of this document</p> <p>EN 1993-1-1 §6.3.2.2</p> <p>EN 1993-1-1 §6.3.2.3</p>

Title	APPENDIX D Worked Example: Design of portal frame using elastic analysis	28 of 44
<p>$\bar{\lambda}_{LT,0} = 0,4$ and $\beta = 0,75$</p> <p>$\frac{h}{b} = 2,37$</p> <p>→ Curve c for hot rolled I sections</p> <p>→ $\alpha_{LT} = 0,49$</p> <p>$\phi_{LT} = 0,5 \left[1 + 0,49(0,470 - 0,4) + 0,75 \times 0,470^2 \right] = 0,60$</p> $\chi_{LT} = \frac{1}{\phi_{LT} + \sqrt{\phi_{LT}^2 - \beta \bar{\lambda}_{LT}^2}}$ $\chi_{LT} = \frac{1}{0,60 + \sqrt{0,60^2 - 0,75 \times 0,470^2}} = 0,961$ $\frac{1}{\bar{\lambda}_{LT}^2} = \frac{1}{0,470^2} = 4,53$ <p>∴ $\chi_{LT} = 0,961$</p> $M_{b,Rd} = \frac{\chi_{LT} W_{pl,y} f_y}{\gamma_{M1}} = \frac{0,961 \times 1702 \times 10^3 \times 355}{1,0} \times 10^{-6} = 581 \text{ kNm}$ <p>$M_{Ed} = 356 \text{ kNm} < 581 \text{ kNm}$ OK</p> <p>Interaction of axial force and bending moment – out-of-plane buckling</p> <p>Out-of-plane buckling due to the interaction of axial force and bending moment is verified by satisfying the following expression:</p> $\frac{N_{Ed}}{N_{b,z,Rd}} + k_{zy} \frac{M_{y,Ed}}{M_{b,Rd}} \leq 1,0$ <p>For $\bar{\lambda}_z \geq 0,4$, the interaction factor, k_{zy} is calculated as:</p> $k_{zy} = \max \left[\left(1 - \frac{0,1 \bar{\lambda}_z}{(C_{mLT} - 0,25)} \frac{N_{Ed}}{N_{b,z,Rd}} \right); \left(1 - \frac{0,1}{(C_{mLT} - 0,25)} \frac{N_{Ed}}{N_{b,z,Rd}} \right) \right]$ <p>The bending moment is approximately linear and constant. Therefore C_{mLT} is taken as 1.0</p> $k_{zy} = \max \left[\left(1 - \frac{0,1 \times 0,540}{(1 - 0,25)} \frac{127}{3034} \right); \left(1 - \frac{0,1}{(1 - 0,25)} \frac{127}{3034} \right) \right]$ $= \max (0,997; 0,994) = 0,997$ $\frac{N_{Ed}}{N_{b,z,Rd}} + k_{zy} \frac{M_{y,Ed}}{M_{b,Rd}} = \frac{127}{3034} + 0,997 \frac{356}{581} = 0,653 < 1,0 \quad \text{OK}$		<p>EN 1993-1-1 Table 6.3 Table 6.5</p> <p>EN 1993-1-1 §6.3.2.3</p> <p>EN 1993-1-1 §6.3.3(4)</p> <p>EN 1993-1-1 Annex B Table B.3 EN 1993-1-1 Annex B Table B.2</p>

7.9.2. End-of-span region

In this region the bottom flange is in compression and stability must be checked between torsional restraints.

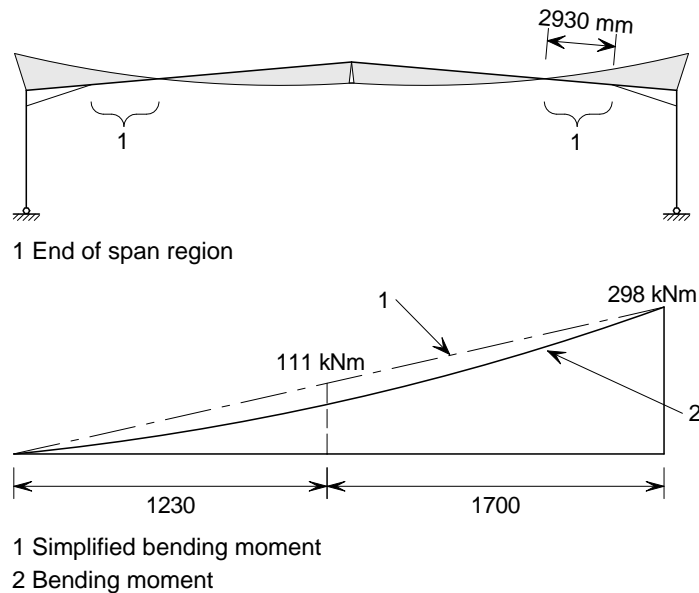

The buckling length is taken from the torsional restraint at the sharp end of the haunch to the 'virtual' restraint which is the point of contraflexure of the bending moment diagram, i.e. where the bending moment is equal to zero. In some countries the assumption of a virtual restraint may not be common practice. If the practice is not allowed, the buckling length should be taken to the next purlin (i.e the first restraint to the compression flange).

From the analysis, the buckling length to the point of contraflexure is 2930 mm.

If the tension flange is restrained at discrete points between the torsional restraints and the spacing between the restraints to the tension flange is small enough, advantage may be taken of this situation.

In order to determine whether or not the spacing between restraints is small enough, Annex BB of EN 1993-1-1 provides an expression to calculate the maximum spacing. If the actual spacing between restraints is smaller than this calculated value, then the methods given in Appendix C of this document may be used to calculate the elastic critical force and the critical moment of the section.

Verification of spacing between intermediate restraints

In this case, the restraint to the tension flange is provided by the purlins. These purlins are spaced at 1700 mm.

$$L_m = \frac{38i_z}{\sqrt{\frac{1}{57,4} \left(\frac{N_{Ed}}{A} \right) + \frac{1}{756 C_1^2} \frac{W_{pl,y}^2}{AI_t} \left(\frac{f_y}{235} \right)^2}}$$

EN 1993-1-1
Annex BB
§BB.3.1.1

Title	APPENDIX D Worked Example: Design of portal frame using elastic analysis	30 of 44
<p> $\psi = \frac{111}{298} = 0,37 \rightarrow C_1 = 1,42$ $L_m = \frac{38 \times 41,2}{\sqrt{\frac{1}{57,4} \left(\frac{127 \times 10^3}{9880} \right) + \frac{1}{756 \times 1,42^2} \frac{(1702 \times 10^3)^2}{9880 \times 66,9 \times 10^4} \left(\frac{355}{235} \right)^2}}$ $L_m = 1669 \text{ mm}$ Purlin spacing is 1700 mm > 1669 mm Therefore the normal design procedure must be adopted and advantage may not be taken of the restraints to the tension flange. </p> <p> Flexural buckling resistance about the minor axis, $N_{b,z,Rd}$ As previously: → Curve b for hot rolled I sections → $\alpha_z = 0,34$ $\lambda_1 = \pi \sqrt{\frac{E}{f_y}} = \pi \sqrt{\frac{210000}{355}} = 76,4$ $\bar{\lambda}_z = \frac{L_{cr}}{i_z} \frac{1}{\lambda_1} = \frac{2930}{41,2} \times \frac{1}{76,4} = 0,931$ $\phi_z = 0,5 \left[1 + \alpha_z (\bar{\lambda}_z - 0,2) + \bar{\lambda}_z^2 \right]$ $\phi_z = 0,5 \left[1 + 0,34(0,931 - 0,2) + 0,931^2 \right] = 1,06$ $\chi_z = \frac{1}{\phi_z + \sqrt{\phi_z^2 - \bar{\lambda}_z^2}} = \frac{1}{1,06 + \sqrt{1,06^2 - 0,931^2}} = 0,638$ $N_{b,z,Rd} = \frac{\chi_z A f_y}{\gamma_{M1}} = \frac{0,638 \times 9880 \times 355}{1,0} \times 10^{-3} = 2238 \text{ kN}$ $N_{Ed} = 127 \text{ kN} < 2238 \text{ kN} \quad \text{OK}$ </p> <p> Lateral-torsional buckling resistance, $M_{b,Rd}$ As previously the C_1 factor needs to be calculated in order to determine the critical moment of the member. For simplicity, the bending moment diagram is considered as linear, which is slightly conservative. </p> <p> $\psi = \frac{0}{298} = 0 \rightarrow C_1 = 1,77$ </p>	<p>Appendix C of this document</p> <p>EN 1993-1-1 Table 6.2 Table 6.1</p> <p>EN 1993-1-1 §6.3.1.3</p> <p>EN 1993-1-1 §6.3.1.2</p> <p>Appendix C of this document</p>	

Title	APPENDIX D Worked Example: Design of portal frame using elastic analysis	31 of 44
$M_{cr} = C_1 \frac{\pi^2 EI_z}{L^2} \sqrt{\frac{I_w}{I_z} + \frac{L^2 GI_t}{\pi^2 EI_z}}$ $= 1,77 \times \frac{\pi^2 \times 210000 \times 1676 \times 10^4}{2930^2}$ $\times \sqrt{\frac{791 \times 10^9}{1676 \times 10^4} + \frac{2930^2 \times 81000 \times 66,9 \times 10^4}{\pi^2 \times 210000 \times 1676 \times 10^4}}$ $M_{cr} = 1763 \times 10^6 \text{ Nmm}$ $\bar{\lambda}_{LT} = \sqrt{\frac{W_{pl,y} f_y}{M_{cr}}} = \sqrt{\frac{1702 \times 10^3 \times 355}{1763 \times 10^6}} = 0,585$ <p>For hot rolled sections</p> $\phi_{LT} = 0,5 \left[1 + \alpha_{LT} (\bar{\lambda}_{LT} - \bar{\lambda}_{LT,0}) + \beta \bar{\lambda}_{LT}^2 \right]$ $\bar{\lambda}_{LT,0} = 0,4 \quad \text{and} \quad \beta = 0,75$ <p>As previously:</p> <p>→ Curve c for hot rolled I sections</p> <p>→ $\alpha_{LT} = 0,49$</p> $\phi_{LT} = 0,5 \left[1 + 0,49(0,585 - 0,4) + 0,75 \times 0,585^2 \right] = 0,674$ $\chi_{LT} = \frac{1}{\phi_{LT} + \sqrt{\phi_{LT}^2 - \beta \bar{\lambda}_{LT}^2}}$ $\chi_{LT} = \frac{1}{0,674 + \sqrt{0,674^2 - 0,75 \times 0,585^2}} = 0,894$ $\frac{1}{\bar{\lambda}_{LT}^2} = \frac{1}{0,585^2} = 2,92$ <p>∴ $\chi_{LT} = 0,894$</p> $M_{b,Rd} = \frac{\chi_{LT} W_{pl,y} f_y}{\gamma_{M1}} = \frac{0,894 \times 1702 \times 10^3 \times 355}{1,0} \times 10^{-6} = 540 \text{ kNm}$ <p>Interaction of axial force and bending moment – out-of-plane buckling</p> <p>Out-of-plane buckling due to the interaction of axial force and bending moment is verified by satisfying the following expression:</p> $\frac{N_{Ed}}{N_{b,z,Rd}} + k_{zy} \frac{M_{y,Ed}}{M_{b,Rd}} \leq 1,0$		<p>Appendix C of this document</p> <p>EN 1993-1-1 §6.3.2.2</p> <p>EN 1993-1-1 §6.3.2.3</p> <p>EN 1993-1-1 Table 6.3 Table 6.5</p> <p>EN 1993-1-1 §6.3.2.3</p> <p>EN 1993-1-1 §6.2.5(2)</p> <p>EN 1993-1-1 §6.3.3(4)</p>

For $\bar{\lambda}_z \geq 0,4$, the interaction factor, k_{zy} , is calculated as:

$$k_{zy} = \max \left[\left(1 - \frac{0,1 \bar{\lambda}_z}{(C_{mLT} - 0,25)} \frac{N_{Ed}}{N_{b,z,Rd}} \right); \left(1 - \frac{0,1}{(C_{mLT} - 0,25)} \frac{N_{Ed}}{N_{b,z,Rd}} \right) \right]$$

$$\psi = \frac{0}{298} = 0$$

$$C_{mLT} = 0,6 + 0,4\psi = 0,6 + 0,4 \times 0 = 0,6$$

$$k_{zy} = \max \left[\left(1 - \frac{0,1 \times 0,931}{(0,6 - 0,25)} \frac{127}{2238} \right); \left(1 - \frac{0,1}{(0,6 - 0,25)} \frac{127}{2238} \right) \right]$$

$$= \max (0,985; 0,983) = 0,985$$

$$\frac{N_{Ed}}{N_{b,z,Rd}} + k_{zy} \frac{M_{y,Ed}}{M_{b,Rd}} = \frac{127}{2238} + 0,985 \frac{298}{540} = 0,601 < 1,0 \quad \text{OK}$$

EN 1993-1-1
Annex B
Table B.3

EN 1993-1-1
Annex B
Table B.2

7.10. In-plane buckling

The in-plane buckling interaction is verified with expression (6.61) in EN 1993-1-1.

$$\frac{N_{Ed}}{N_{b,y,Rd}} + k_{yy} \frac{M_{y,Ed}}{M_{b,Rd}} \leq 1,0$$

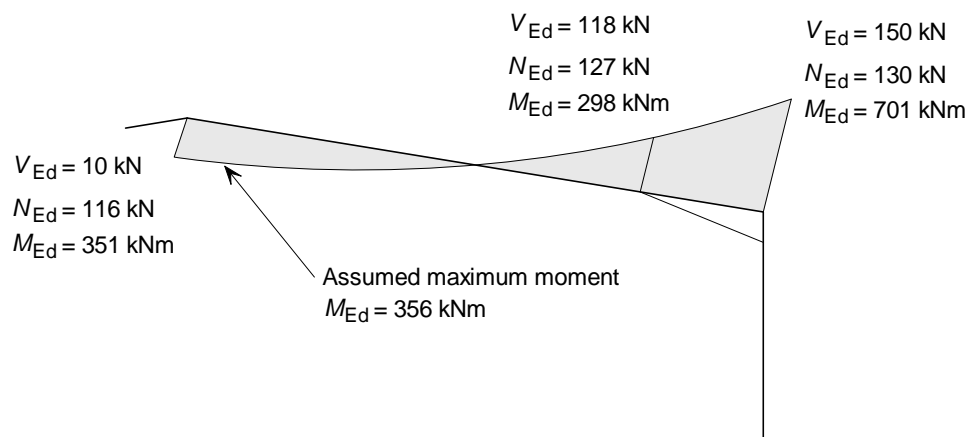

Maximum bending moment and axial force in the rafter, excluding the haunch.

$$M_{Ed} = 356 \text{ kNm}$$

$$N_{Ed} = 127 \text{ kN}$$

The haunch is analysed in Section 8.

Title	APPENDIX D Worked Example: Design of portal frame using elastic analysis	33 of 44	
<p>7.10.1. Flexural buckling resistance about the mayor axis, $N_{b,y,Rd}$</p> $\frac{h}{b} = \frac{450}{190} = 2,37$ <p>$t_f = 14,6$ mm</p> <p>buckling about y-y axis: → Curve a for hot rolled I sections → $\alpha = 0,21$</p> <p>The buckling length is the system length, which is the distance between the joints (i.e. the length of the rafter, including the haunch), $L = 15057$ mm</p> $\lambda_1 = \pi \sqrt{\frac{E}{f_y}} = \pi \sqrt{\frac{210000}{355}} = 76,4$ $\bar{\lambda}_y = \frac{L_{cr}}{i_y} \frac{1}{\lambda_1} = \frac{15057}{185} \times \frac{1}{76,4} = 1,065$ $\phi_y = 0,5 \left[1 + \alpha_y (\bar{\lambda}_y - 0,2) + \bar{\lambda}_y^2 \right]$ $\phi_y = 0,5 \left[1 + 0,21(1,065 - 0,2) + 1,065^2 \right] = 1,158$ $\chi_y = \frac{1}{\phi_y + \sqrt{\phi_y^2 - \bar{\lambda}_y^2}} = \frac{1}{1,158 + \sqrt{1,158^2 - 1,065^2}} = 0,620$ $N_{b,y,Rd} = \frac{\chi_y A f_y}{\gamma_{M1}} = \frac{0,620 \times 9880 \times 355}{1,0} \times 10^{-3} = 2175 \text{ kN}$ <p>$N_{Ed} = 127 \text{ kN} < 2175 \text{ kN}$ OK</p> <p>7.10.2. Lateral-torsional buckling resistance, $M_{b,Rd}$</p> <p>$M_{b,Rd}$ is the least buckling moment resistance of those calculated before.</p> $M_{b,Rd} = \min(581; 540)$ <p>$M_{b,Rd} = 540 \text{ kNm}$</p> <p>7.10.3. Interaction of axial force and bending moment – in-plane buckling</p> <p>In-plane buckling due to the interaction of axial force and bending moment is verified by satisfying the following expression:</p> $\frac{N_{Ed}}{N_{b,y,Rd}} + k_{yy} \frac{M_{y,Ed}}{M_{b,Rd}} \leq 1,0$ <p>The interaction factor, k_{yy}, is calculated as follows:</p> $k_{yy} = \min \left[C_{my} \left(1 + (\bar{\lambda}_y - 0,2) \frac{N_{Ed}}{N_{b,y,Rd}} \right); C_{my} \left(1 + 0,8 \frac{N_{Ed}}{N_{b,y,Rd}} \right) \right]$			<p>EN 1993-1-1 Table 6.1 Table 6.2</p> <p>EN 1993-1-1 §6.3.1.3</p> <p>EN 1993-1-1 §6.3.1.2</p>

The expression for C_{my} depends on the values of α_h and ψ .

$$\psi = -\frac{298}{351} = -0,849.$$

$$\alpha_h = \frac{M_h}{M_s} = \frac{351}{356} = 0,986$$

Therefore C_{my} is calculated as:

$$C_{my} = 0,95 + 0,05\alpha_h = 0,95 + 0,05 \times 0,986 \approx 1,0$$

$$k_{yy} = \min \left[1,0 \left(1 + (1,065 - 0,2) \frac{127}{2175} \right); 1 \left(1,0 + 0,8 \frac{127}{2175} \right) \right]$$

$$= \min [1,05; 1,047] = 1,047$$

$$\frac{N_{Ed}}{N_{b,y,Rd}} + k_{yy} \frac{M_{y,Ed}}{M_{b,Rd}} = \frac{127}{2175} + 1,047 \frac{356}{517} = 0,779 < 1,0 \quad \text{OK}$$

The member satisfies the in-plane buckling check.

EN 1993-1-1
Annex B Table
B.3

EN 1993-1-1
Annex B
Table B.2

7.11. Validity of rafter section

In Section 7.8 it has been demonstrated that the cross-sectional resistance of the section is greater than the applied forces.

The out-of-plane and in-plane buckling checks have been verified in Sections 7.9 and 7.10 for the appropriate choice of restraints along the rafter.

Therefore it is concluded that the IPE500 section in S355 steel is appropriate for use as rafter in this portal frame.

8. Haunched length

The haunch is fabricated from a cutting of an IPE 550 section. Checks must be carried out at end and quarter points, as indicated in the figure below.

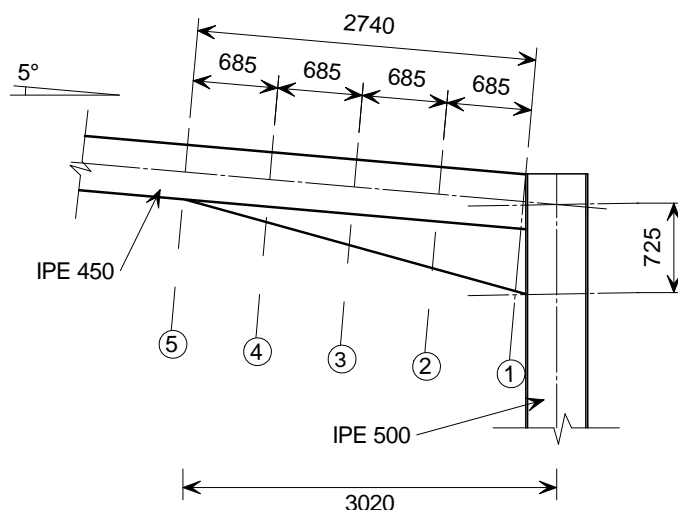

From the geometry of the haunch, the following properties can be obtained for each of the cross-sections 1 to 5, as shown in Table 2.

Table 2 Section properties of haunched member at cross-section, as per figure above

Cross-section no.	Cutting depth (mm)	Overall depth (mm)	Gross area, A (mm^2)	I_y (mm^4)	$W_{el,min}$ (mm^3)	N_{Ed} (kN)	M_{Ed} (kNm)
1	503	953	15045	200500	4055	129	661
2	378	828	13870	144031	3348	129	562
3	252	702	12686	98115	2685	128	471
4	126	576	11501	62258	2074	127	383
5	0	450	9880	33740	1500	127	298

The section properties are calculated normal to the axis of the section.

For simplicity, the section properties above have been calculated assuming a constant web thickness of 9,4 mm and neglecting the middle flange.

The actual and the equivalent cross-sections are shown in the following figure for cross-section No.1:

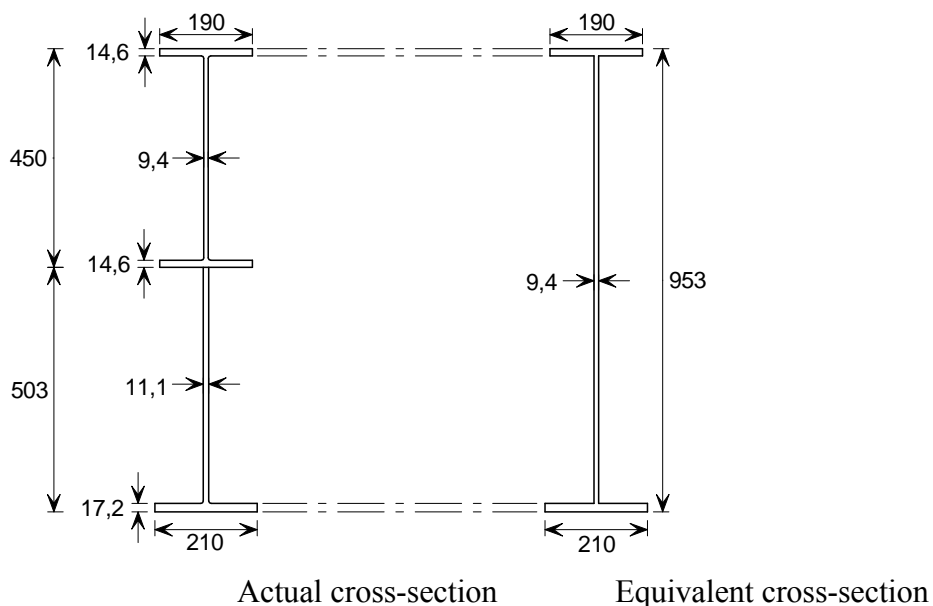

For cross-section No.1 the values of N_{Ed} and M_{Ed} are taken at the face of the column.

8.1. Cross-section classification

8.1.1. The web

The web can be divided into two webs, and classified according to the stress and geometry of each web. The upper section (i.e. the rafter) is called the upper web and the lower section (i.e. the cutting) is called the lower web.

Upper web

By inspection the upper web will be Class 3 or better, because it is mostly in tension.

Lower web

Stress in the section caused by axial load:

$$\sigma_N = \frac{129}{15045} \times 10^3 = 8,57 \text{ N/mm}^2$$

Assuming an elastic stress distribution in cross-section No.1, the maximum stress available to resist bending is:

$$\sigma_M = \frac{f_y}{\gamma_{M0}} - \sigma_N = \frac{355}{1,0} - 8,57 = 346 \text{ N/mm}^2$$

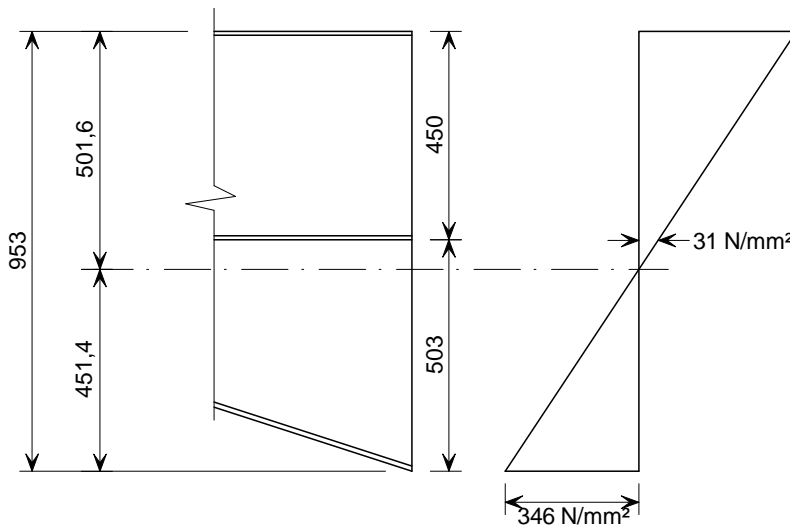

The distance from the bottom flange to the elastic neutral axis is:

$$\bar{z} = 451,4 \text{ mm}$$

Distance from underside of middle flange to neutral axis: 51,6 mm

Bending + axial stress at the top of cutting section:

$$= 346(-51,6/451,4) + 8,57 = -31 \text{ N/mm}^2$$

For Class 3 check, determine ψ .

$$\psi = \frac{-31}{346} = -0,09$$

Considering section 1 parallel to column flange, the depth of web excluding root radius is:

$$c_w = 503 - 17,2 - 24 = 461,8 \text{ mm}$$

$$\frac{c_w}{t_w} = \frac{461,8}{11,1} = 41,6$$

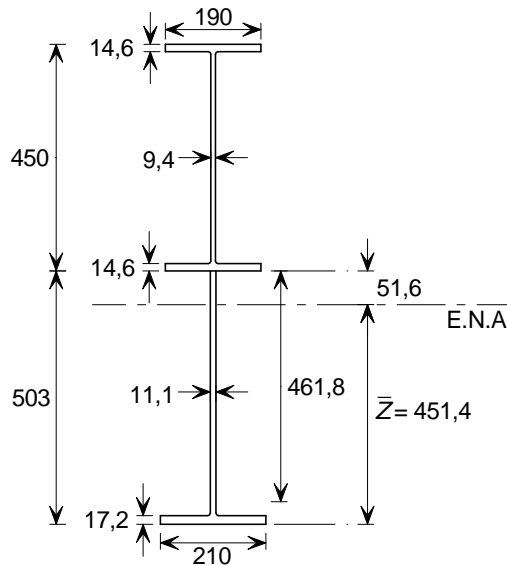

EN 1993-1-1
Table 5.2

For $\psi > -1$, the limit for Class 3 is:

$$\frac{42 \varepsilon}{0,67 + 0,33\psi} = \frac{42 \times 0,81}{0,67 + 0,33(-0,09)} = 53,1$$

$$\frac{c}{t_w} = 41,6 < 53,1$$

→ The web is Class 3

8.1.2. The flanges

Top flange

$$\frac{c}{t_f} = \frac{69,3}{14,6} = 4,7$$

The limit for Class 1 is : $9 \varepsilon = 9 \times 0,81 = 7,3$

$$\text{Then : } \frac{c}{t_f} = 4,7 < 7,3$$

→ The top flange is Class 1

Bottom flange

$$\frac{c}{t_f} = \frac{75,45}{17,2} = 4,4$$

The limit for Class 1 is : $9 \varepsilon = 9 \times 0,81 = 7,3$

$$\frac{c}{t_f} = 4,4 < 7,3$$

→ The bottom flange is Class 1

Therefore the overall section is Class 3.

EN 1993-1-1
Table 5.2

EN 1993-1-1
Table 5.2
(Sheet 2)

8.2. Cross-sectional resistance

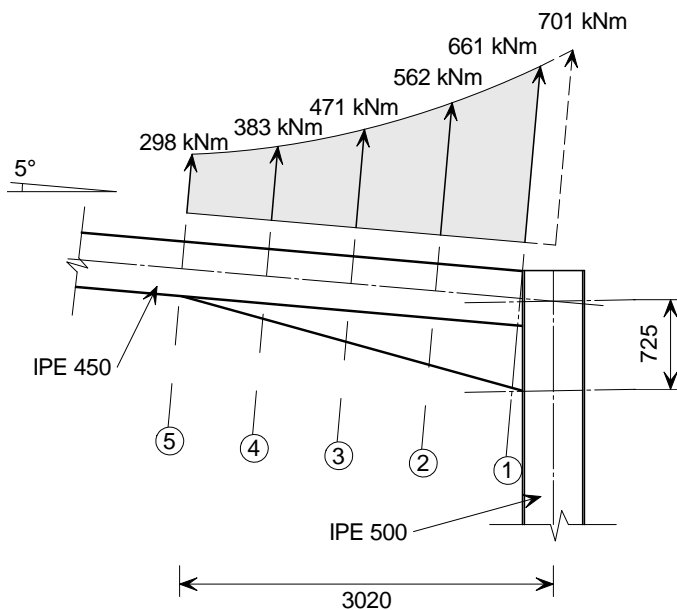

8.2.1. Shear resistance

The shear area of cross-section No.1 can be conservatively estimated as:

$$A_v = A - (bt_f)_{\text{topfl}} - (bt_f)_{\text{botfl}} = 15045 - 190 \times 14,6 - 210 \times 17,2 = 8659 \text{ mm}^2$$

$$V_{\text{pl,Rd}} = \frac{A_v (f_y / \sqrt{3})}{\gamma_{\text{M0}}} = \frac{8659 (355 / \sqrt{3})}{1,0} \times 10^{-3} = 1775 \text{ kN}$$

$$V_{\text{Ed}} = 147 \text{ kN} < 1775 \text{ kN} \quad \text{OK}$$

Bending and shear interaction:

When shear force and bending moment act simultaneously on a cross-section, the shear force can be ignored if it is smaller than 50% of the plastic shear resistance.

$$V_{\text{Ed}} = 147 \text{ kN} < 0,5 V_{\text{pl,Rd}} = 888 \text{ kN}$$

Therefore the effect of the shear force on the moment resistance may be neglected.

The same calculation must be carried out for the remaining cross-sections. The table below summarizes the shear resistance verification for the haunched member:

Table 3 Shear verification for cross-sections 1 to 5

Cross-section no.	V_{Ed} (kN)	A_v (mm ²)	$V_{\text{pl,Rd}}$ (kN)	$V_{\text{Ed}} \leq V_{\text{Rd}}$	$0,5 V_{\text{Rd}}$ (kN)	Bending and shear interaction
1	147	8659	1775	Yes	888	No
2	140	7484	1534	Yes	767	No
3	132	6300	1291	Yes	646	No
4	125	5115	1048	Yes	524	No
5	118	5082	1042	Yes	521	No

EN 1993-1-1
§6.2.6

8.2.2. Compression resistance

The compression resistance of cross-section No.1:

$$N_{c,Rd} = \frac{A f_y}{\gamma_{M0}} = \frac{15045 \times 355}{1,0} \times 10^{-3} = 5341 \text{ kN}$$

$$N_{Ed} = 129 \text{ kN} < 5341 \text{ kN} \quad \text{OK}$$

Bending and axial force interaction:

When axial force and bending moment act simultaneously on a cross-section, the total stress, $\sigma_{x,Ed}$, must be less than the allowable stress.

$$\sigma_{x,Ed} = \sigma_N + \sigma_M$$

$$\sigma_M = \frac{M_{Ed} \times z}{I_y} = \frac{661 \times 10^6 \times 501,6}{200500 \times 10^4} = 165 \text{ N/mm}^2$$

$$\sigma_{x,Ed} = \sigma_N + \sigma_M = 8,57 + 165 = 174 \text{ N/mm}^2$$

The maximum allowable stress is:

$$\sigma_{max} = \frac{f_y}{\gamma_{M0}} = \frac{355}{1,0} = 355 \text{ N/mm}^2$$

$$\sigma_{x,Ed} = 174 \text{ N/mm}^2 < 355 \text{ N/mm}^2 \quad \text{OK}$$

A similar calculation must be carried out for the remaining cross-sections. The table below summarize compression resistance verification for the haunched member:

Table 4 Compression verification for cross-sections 1 to 5

Cross-section (i)	N_{Ed} (kN)	A (mm ²)	$N_{c,Rd}$ (kN)	$N_{Ed} \leq N_{c,Rd}$	Bending and axial interaction
1	129	15045	5341	Yes	No
2	129	13870	4924	Yes	No
3	128	12686	4504	Yes	No
4	127	11501	4083	Yes	No
5	127	9880	3507	Yes	No

8.2.3. Bending moment resistance

The bending moment resistance of cross-section No.1 is:

$$M_{c,y,Rd} = M_{el,y,Rd} = \frac{W_{el,min} f_y}{\gamma_{M0}} = \frac{4055 \times 10^3 \times 355}{1,0} \times 10^{-6} = 1440 \text{ kNm}$$

$$M_{y,Ed} = 661 \text{ kNm} < 1440 \text{ kNm} \quad \text{OK}$$

A similar calculation must be carried out for the remaining cross-sections. The table below summarizes bending moment resistance verification for the haunched member.

EN 1993-1-1
§6.2.4

EN 1993-1-1
§6.2.9.2

EN 1993-1-1
§6.2.5(2)

In this case, all cross-sections have been treated as Class 3, and therefore the elastic properties have been used. This is conservative. However, from previous calculations carried out to check the rafter, it is observed that cross-section No.1 is Class 1. It may be that other sections between cross-sections No.1 and No.5 are plastic sections and therefore a greater moment resistance could be achieved.

Table 5 Bending verification for cross-sections 1 to 5

Cross-section (i)	M_{Ed} (kNm)	$W_{el,min}$ ($mm^3 \times 10^3$)	$M_{el,Rd}$ (kNm)	$M_{Ed} \leq M_{el,Rd}$
1	661	4055	1440	Yes
2	562	3348	1189	Yes
3	471	2685	953	Yes
4	383	2074	736	Yes
5	298	1500	533	Yes

8.3. Buckling resistance

There is a torsional restraint at each end of the haunched length.

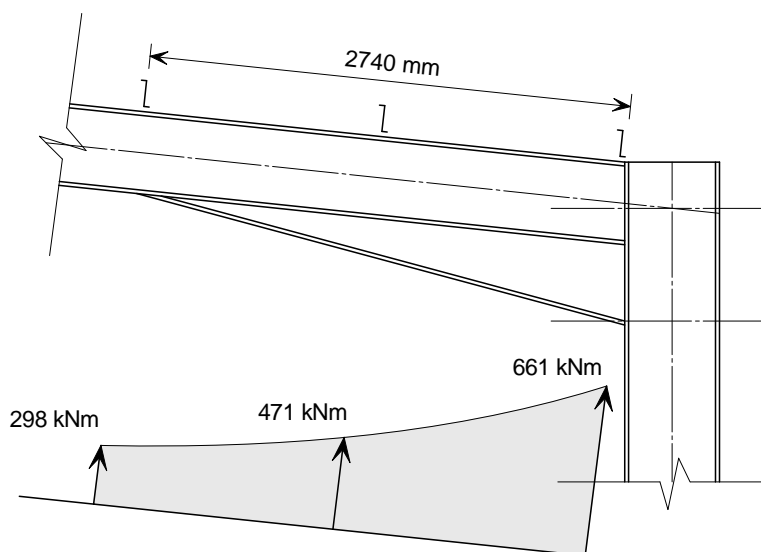

Buckling length considered

When the tension flange is restrained at discrete points between the torsional restraints and the spacing between the restraints to the tension flange is small enough, advantage may be taken of this situation.

In order to determine whether or not the spacing between restraints is small enough, Annex BB of EN 1993-1-1 provides an expression to calculate the maximum spacing. If the actual spacing between restraints is smaller than this calculated value, then the methods given in Appendix C of this document may be used to calculate the elastic critical force and the critical moment of the section.

On the contrary, if the spacing between restraints is larger than the calculated value, an equivalent T-section may be used to check the stability of the haunch.

8.3.1. Verification of spacing between intermediate restraints

$$L_m = \frac{38i_z}{\sqrt{\frac{1}{57,4} \left(\frac{N_{Ed}}{A} \right) + \frac{1}{756 C_1^2} \frac{W_{pl,y}^2}{AI_t} \left(\frac{f_y}{235} \right)^2}}$$

For simplicity, the purlin at mid-span of the haunched member is assumed to be aligned with the cross-section No. 3.

Equally, the purlin at the end of the haunched member is assumed to be aligned with the cross-section No. 1.

$$\psi = \frac{471}{661} = 0,71 \rightarrow C_1 = 1,2$$

According to the Eurocode, the ratio $\frac{W_{pl}^2}{AI_t}$ should be taken as the maximum value in the segment.

In this case cross-sections No.1 and 3 have been considered, as shown in Table 6.

Table 6 $\frac{W_{pl}^2}{AI_t}$ ratio for cross-sections No.1 and 3

Cross-section (i)	A (mm ²)	<i>I_t</i> (mm ⁴) × 10 ⁴	W _{pl} (mm ³) × 10 ³	$\frac{W_{pl}^2}{AI_t}$
1	15045	81	4888	1961
3	12686	74	3168	1069

For simplicity, in the calculation of *I_t* and W_{pl}, the middle flange has been neglected.

The section properties of cross-section No.1 give the maximum ratio $\frac{W_{pl}^2}{AI_t}$.

Therefore *L_m* is calculated using the section properties of cross-section No.1.

$$I_z = 2168 \times 10^4 \text{ mm}^4$$

$$i_z = \sqrt{\frac{I_z}{A}} = \sqrt{\frac{2168 \times 10^4}{15045}} = 38 \text{ mm}$$

$$L_m = \frac{38 \times 38}{\sqrt{\frac{1}{57,4} \left(\frac{129 \times 10^3}{15045} \right) + \frac{1}{756 \times 1,2^2} \frac{(4888 \times 10^3)^2}{15045 \times 81 \times 10^4} \left(\frac{355}{235} \right)^2}}$$

$$L_m = 700 \text{ mm}$$

Purlin spacing is 1345 mm \nless 700 mm

Therefore the design procedure taking advantage of the restraints to the tension flange given in Section C.2 of Appendix C cannot be used.

EN 1993-1-1
Annex BB
§BB.3.2.1

Appendix C of
this document

EN 1993-1-1
Annex BB
§BB.3.2.1

8.3.2. Verification of flexural buckling about minor axis

Maximum forces in the haunched member (at the face of the column) are:

$$N_{Ed} = 129 \text{ kN}$$

$$M_{Ed} = 661 \text{ kNm}$$

EN 1993-1-1 does not cover the design of tapered sections (i.e. a haunch), and the verification in this worked example is carried out by checking the forces of an equivalent T-section subject to compression and bending.

The equivalent T-section is taken from a section at mid-length of the haunched member.

The equivalent T-section is made of the bottom flange and 1/3 of the compressed part of the web area, based on §6.3.2.4 of EN 1993-1-1.

The buckling length is 2740 mm (length between the top of column and the first restraint).

Properties of cross-section No.1:

Section area $A = 15045 \text{ mm}^2$

Elastic modulus to the compression flange $W_{el,y} = 4527 \times 10^3 \text{ mm}^3$

Properties of cross-section No.3:

Properties of the whole section

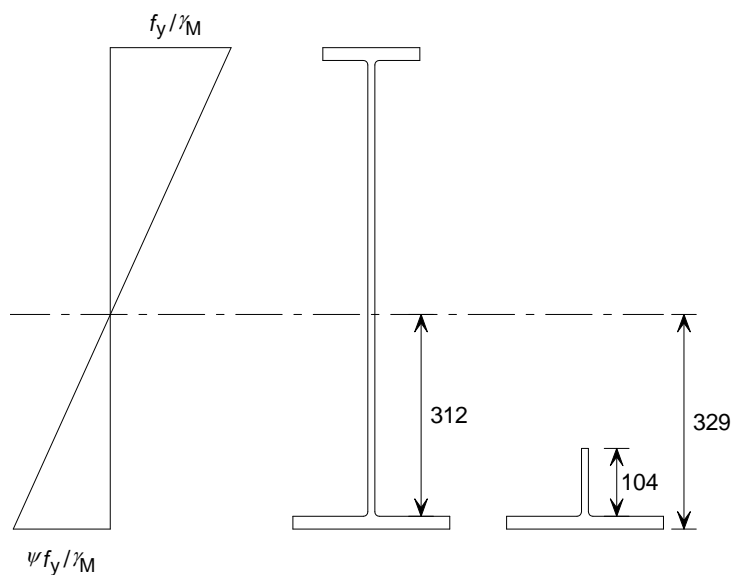

Elastic neutral axis (from bottom flange): $\bar{z} = 329 \text{ mm}$

Section area $A = 12686 \text{ mm}^2$

Properties of the equivalent T-section in compression:

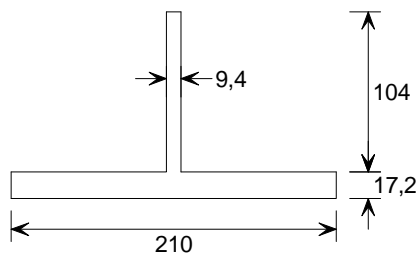

Area of T-section:

$$A_f = 4590 \text{ mm}^2$$

Second moment of area about the minor axis:

$$I_{f,z} = 1328 \times 10^4 \text{ mm}^4$$

Compression in the T-section

The total equivalent compression in the T-section is calculated for cross-section No.1 by adding the direct axial compression and the compression due to bending.

$$N_{\text{Ed},f} = N_{\text{Ed}} \times \frac{A_f}{A} + \frac{M_{\text{Ed}}}{W_{\text{el},y}} \times A_f = 129 \times \frac{4590}{15045} + \frac{661 \times 10^6}{4527 \times 10^3} \times 4590 = 670 \text{ kN}$$

Verification of buckling resistance about the minor axis

Buckling curve c is used for hot rolled sections

$$\rightarrow \alpha_z = 0,49$$

$$\lambda_1 = \pi \sqrt{\frac{E}{f_y}} = \pi \sqrt{\frac{210000}{355}} = 76,4$$

$$i_{f,z} = \sqrt{\frac{I_{f,z}}{A_f}} = \sqrt{\frac{1328 \times 10^4}{4590}} = 53,8$$

$$\bar{\lambda}_{f,z} = \frac{L_{\text{cr}}}{i_{f,z}} \frac{1}{\lambda_1} = \frac{2740}{53,8} \times \frac{1}{76,4} = 0,667$$

$$\phi_z = 0,5 \left[1 + \alpha_z (\bar{\lambda}_{f,z} - 0,2) + \bar{\lambda}_{f,z}^2 \right]$$

$$\phi_z = 0,5 \left[1 + 0,49(0,667 - 0,2) + 0,667^2 \right] = 0,837$$

$$\chi_z = \frac{1}{\phi_z + \sqrt{\phi_z^2 - \bar{\lambda}_{f,z}^2}} = \frac{1}{0,837 + \sqrt{0,837^2 - 0,667^2}} = 0,745$$

$$N_{\text{b},z,\text{Rd}} = \chi_z \frac{A f_y}{\gamma_{\text{M}0}} = 0,745 \frac{4590 \times 355}{1,0} \times 10^{-3} = 1214 \text{ kN}$$

$$N_{\text{Ed},f} = 670 \text{ kN} < 1214 \text{ kN} \quad \text{OK}$$

EN 1993-1-1
§6.3.1.2

EN 1993-1-1
§6.3.1.2

9. Deflections

The horizontal and vertical deflections of the portal frame subject to the characteristic load combination, as per Expression 6.14 of EN 1990 are as follows:

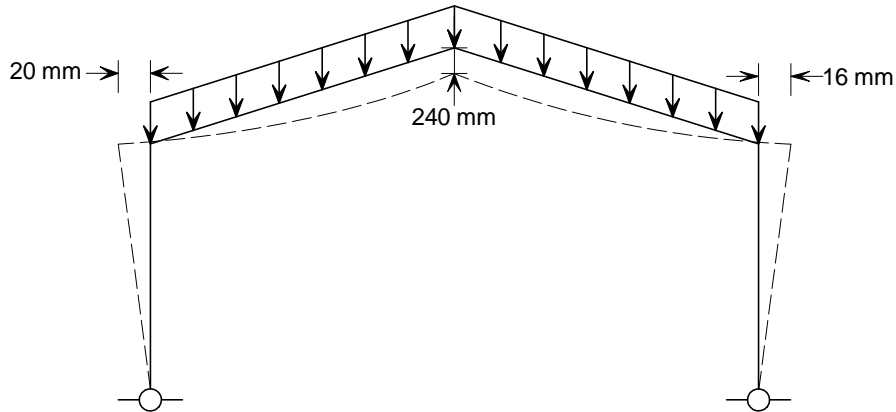

Appendix A of this document provides typical deflection limits used in some European countries. These limits are only intended to be a guideline. The requirements for a given portal frame design must be agreed with the client.