



**TATA STEEL**



Steel Bridge Group:  
Guidance Notes on Best Practice  
in Steel Bridge Construction  
*Fifth Issue*



SCI (The Steel Construction Institute) is the leading, independent provider of technical expertise and disseminator of best practice to the steel construction sector. We work in partnership with clients, members and industry peers to help build businesses and provide competitive advantage through the commercial application of our knowledge. We are committed to offering and promoting sustainable and environmentally responsible solutions.

Our service spans the following five areas:

**Membership**

- Individual and corporate membership

**Technical information**

- Courses
- Publications
- Online reference tools
- Education
- Codes and standards

**Construction solutions**

- Sustainability
- Product development
- Research
- Engineering solutions

**Communications technology**

- Websites
- Communities
- Design tools

**Assessment**

- SCI assessed

The Steel Construction Institute, Silwood Park, Ascot, Berkshire, SL5 7QN.

Telephone: +44 (0) 1344 636525

Fax: +44 (0) 1344 636570

Email: [membership@steel-sci.com](mailto:membership@steel-sci.com)

For information on publications, telephone direct: +44 (0) 1344 636513

or Email: [publications@steel-sci.com](mailto:publications@steel-sci.com)

For information on courses, telephone direct: +44 (0) 1344 636500

or Email: [education@steel-sci.com](mailto:education@steel-sci.com)

World Wide Web site: [www.steel-sci.org](http://www.steel-sci.org)

24 X 7 technical information: [www.steelbiz.org](http://www.steelbiz.org)

# **Steel Bridge Group: Guidance Notes on Best Practice in Steel Bridge Construction**

*(Fifth issue, March 2010)*

Edited by:

C R HENDY MA(Cantab) CEng FICE  
D C ILES MSc, ACGI, DIC, CEng, MICE

Published by:

The Steel Construction Institute  
Silwood Park  
Ascot  
Berkshire SL5 7QN

Tel: 01344 636525  
Fax: 01344 636570

© 2010 The Steel Construction Institute

Apart from any fair dealing for the purposes of research or private study or criticism or review, as permitted under the Copyright Designs and Patents Act, 1988, this publication may not be reproduced, stored or transmitted, in any form or by any means, without the prior permission in writing of the publishers, or in the case of reprographic reproduction only in accordance with the terms of the licences issued by the UK Copyright Licensing Agency, or in accordance with the terms of licences issued by the appropriate Reproduction Rights Organisation outside the UK.

Enquiries concerning reproduction outside the terms stated here should be sent to the publishers, The Steel Construction Institute, at the address given on the title page.

Although care has been taken to ensure, to the best of our knowledge, that all data and information contained herein are accurate to the extent that they relate to either matters of fact or accepted practice or matters of opinion at the time of publication, The Steel Construction Institute, the authors and the reviewers assume no responsibility for any errors in or misinterpretations of such data and/or information or any loss or damage arising from or related to their use.

*Publications supplied to the Members of the Institute at a discount are not for resale by them.*

Publication Number: SCI P185 5<sup>th</sup> issue

ISBN: 978-1-85942-196-3

British Library Cataloguing-in-Publication Data.

A catalogue record for this book is available from the British Library.

# FOREWORD

This publication presents a collection of separate Guidance Notes on a range of topics concerning the design and construction of structural steelwork for bridges. It complements the publication *Steel Bridge Group: Model Project Specification*, which was written for use in preparing an execution specification for steel and composite bridges and which makes reference to some of the Guidance Notes in this publication.

This is the fifth issue of this publication, which comprises approximately 60 separate Notes. Each Note was originally drafted by a member of the Steel Bridge Group (SBG) and subsequently developed with assistance and comment from other SBG members. The Notes were published in stages in Issues 1, 2 and 3, from 1998 to 2002. In Issue 4, most of the Notes were updated and the whole set re-issued.

**This new issue** is the result of a thorough review of all the notes and takes account of the change to use of the Structural Eurocodes for design and the revision of many product and executions standards associated with that change. Some of the Notes have been extensively revised, others required only modest attention. The changes are not marked in the Notes themselves as it was considered difficult to properly reflect all the separate additions and deletions.

The Steel Bridge Group is a technical forum that has been established to consider matters of high-priority interest to the steel bridge construction industry and to suggest strategies for improving the use of steel in bridgework. At the time of preparing this fifth issue, the Group included the following members:

Mr C Hendy (Chairman)	Atkins
Mr E Atherton	Cass Hayward
Mr S Bhattacharya	Mouchel
Mr I K Bucknall	Network Rail
Mr S Chakrabarti	Highways Agency
Mr C P E Cocksedge	AECOM
Mr D Dickson	Mabey Bridge Ltd
Mr C Dolling	Tata Steel
Mr J E Evans	Flint & Neill Ltd
Mr R Hornby	Arup
Mr I E Hunter	Consultant (formerly of Cleveland Bridge Ltd)
Mr D C Iles	The Steel Construction Institute
Mr T Knight	Mott MacDonald
Mr S J Matthews	WSP Consulting Engineers
Mr B R Mawson	Consultant (formerly of Gwent Consultancy)
Mr D B Moore	The British Constructional Steelwork Association Ltd
Mr C J Murphy	Flint & Neill Ltd
Mr J D Place	Mott MacDonald
Mr R Thomas	Rowecord Engineering Ltd
Mr G Waley	Edmund Nuttall Ltd

As a result of the representation of diverse interests in the Group, the Guidance Notes may be considered to be guides to good, accepted practice. They should not, however, be taken to provide advice that is universally applicable to any and every project.

SCI expresses thanks to the members of the SBG for the contributions in drafting, debating and revising the original material for these Notes and in carrying out the present revisions in the updated Notes.

The SCI and the members of the SBG assume no responsibility for the adequacy of the advice given, nor for the legal, contractual or financial consequences of its use.

The editorial work in preparing these Guidance Notes has been funded by Tata Steel<sup>\*</sup>; their support is gratefully acknowledged.

**Comments, feedback and suggestions for further Notes will be welcomed; they should be sent to SCI, for the attention of Mr D C Iles, at the address given on the title page.**

---

<sup>\*</sup> This publication includes references to Corus, which is a former name of Tata Steel in Europe

The SCI and the members of the SBG assume no responsibility for the adequacy of the advice given, nor for the legal, contractual or financial consequences of its use.

The editorial work in preparing these Guidance Notes has been funded by Tata Steel Europe\*; their support is gratefully acknowledged.

**Comments, feedback and suggestions for further Notes will be welcomed; they should be sent to SCI, for the attention of Mr D C Iles, at the address given on the title page.**

---

\* Corus is a subsidiary of Tata Steel Europe

# CONTENTS

- Section 1 Design - general
- Section 2 Design - detailing
- Section 3 Materials and products
- Section 4 Contract documentation
- Section 5 Fabrication
- Section 6 Inspection and testing
- Section 7 Erection and in situ construction work
- Section 8 Protective treatment

## USE OF THE PUBLICATION

The Guidance Notes are grouped in eight Sections. Each Section relates to one broad subject, as listed under Contents above.

Each Note is assigned a three digit number, comprising the subject Section number and a two digit serial number; for example, 2.04 is the fourth Guidance Note in Section 2. Two Notes in the series are not in the fifth issue (7.07 and 6.04) and so the sequence contains two gaps.

The number of each Guidance Note is given at the head of every page. Each Note is separately page-numbered in a footer; the page number incorporates the Note number, for example 1.01/2 is the second page of Note 1.01. Cross references from one Note to another are denoted by prefixing the Note number by GN, for example GN 3.01.

A list of all the Guidance Notes is given overleaf.





# LIST OF GUIDANCE NOTES

No.	Title	Revision
1.01	Glossary	R2
1.02	Skew bridges	R2
1.03	Bracing systems	R2
1.04	Bridge articulation	R3
1.05	Structural arrangement	R1
1.06	Noise from steel and composite railway bridges	<i>(unchanged)</i>
1.07	Use of weather resistant steel	R4
1.08	Box girder bridges	R2
1.09	Comparison of bolted and welded splices	R2
1.10	Half through bridges	R2
2.01	Main girder make-up	R1
2.02	Main girder connections	R2
2.03	Bracing and cross girder connections	R2
2.04	Bearing stiffeners	R2
2.05	Intermediate transverse web stiffeners	R2
2.06	Connections made with preloaded bolts	R2
2.07	Welds - how to specify	R2
2.08	Attachment of bearings	R2
2.09	Alignment of bearings	<i>(new Note)</i>
2.10	Steel deck plate for footbridges	R2
2.11	Shear connectors	R1
3.01	Structural steels	R2
3.02	Through thickness properties	R2
3.03	Bridge bearings	R3
3.04	Welding processes and consumables	R2
3.05	Surface defects on steel materials	R2
3.06	Internal defects in steel materials	R2
3.07	Specifying steel material	R2
4.01	Drawings and execution specification	R1
4.02	Weld procedure tests	R2
4.03	Allowing for permanent deformations	R2
4.04	Consideration of alternative construction methods and sequences	R1
5.01	Weld preparation	R2
5.02	Post-weld dressing	R2
5.03	Geometrical tolerances	R2
5.04	Plate bending	R2
5.05	Marking of steelwork	R2

5.06	Thermal cutting of structural steels	R2
5.07	Straightening and flattening	R2
5.08	Hole sizes and positions for preloaded bolts	R2
5.09	The prefabrication meeting	R1
6.01	Control of weld quality and inspection	R2
6.02	Surface inspection of welds	R2
6.03	Sub-surface inspection of welds	R2
6.04	Hydrogen/HAZ cracking and solidification cracking in welds	R2
6.05	<i>(Note withdrawn)</i>	
6.06	Visual inspection after welding	<i>(new Note)</i>
7.01	Site welding	R2
7.02	Temperature effects during construction	R1
7.03	Verticality of webs at supports	R2
7.04	Trial erection and temporary erection	R2
7.05	Installation of preloaded bolts	R2
7.06	Transport of steelwork by road	R2
7.07	<i>(Not issued)</i>	
7.08	Method statements	R2
8.01	Preparing for effective corrosion protection	R3
8.02	Protective treatment of fasteners	R2
8.03	Hot dip galvanizing	R2
8.04	Thermally sprayed metal coatings	R2
8.05	High performance paint coatings.	R2
8.06	The inspection of surface preparation and coating treatments	R2

**Scope**

This Guidance Note offers definitions of some of the terms that are commonly used in the steel bridge construction industry. Many terms are common to other forms of structural steelwork, but some have a particular usage in relation to bridge construction (including terms that have usage for bridges in materials other than steel).

The definitions are provided by the Steel Bridge Group to assist readers of the Guidance Notes. They should not be regarded as contractually definitive. Where definitions from other sources are used (either in whole or in part), the reference is noted at the end of the definition; references to definitions in BS 6100 are given as a seven digit (3 + 4) number.

<b>TERM</b>	<b>DEFINITION</b>
<b>abutment</b>	An end support to a bridge. It may or may not also act as a retaining wall. See also <b>integral abutment</b> (below).
<b>actions</b>	A set of forces (loads) applied to a structure or a set of imposed deformations or accelerations (see EN 1990, 1.5.3.1)
<b>beam</b>	A structural member that carries loads principally in bending, and which spans between main supports or between connections to other members. The primary elements of bridges are usually longitudinal beams.
<b>bearing</b>	A structural device located between the deck and an abutment or pier of the bridge and transferring loads from the deck to the abutment or pier (ENV 1993-2). The bearing allows freedom of relative movement or rotation in some directions.
<b>bearing plate</b>	A seating plate between the underside of a girder flange and the bearing that supports the girder. The plate is typically tapered (with the lower face horizontal and the upper face at the inclination of the bottom flange) and is thus often referred to as a <b>tapered bearing plate</b> . See GN 2.04.
<b>black bolt</b>	A bolt in a clearance hole, designed to transmit load in bearing/shear. <i>Old terminology, not used in Eurocode 3 or EN 1090-2.</i>
<b>bolting assembly for pre-loading</b>	A nut and bolt assembly used in preloaded <b>slip-resistant connections</b> . Formerly referred to as <b>HSFG bolt</b>
<b>bracing</b>	A secondary structural element of a bridge connecting two major parts, usually for stabilisation of those parts against buckling, but also to provide a path for forces transverse to main beams, etc. (e.g. wind bracing).
<b>brittle fracture</b>	The rapid propagation of a crack in a single application of loading, and without any extensive plastic deformation.
<b>camber</b>	A design curvature in the vertical plane of a beam, girder or bridge deck. See GN 4.03.
<b>CEV</b>	Carbon Equivalent Value. A representative measure of the alloy content of steel that affects its weldability.
<b>Charpy test</b>	A test to determine a representative value of the toughness of steel material. A small notched specimen is struck in a special testing machine and the energy absorbed is measured (an <b>impact test</b> ). See GN 3.01.
<b>cope hole</b>	A cut-out or 'hole' at the edge or corner of a planar element to facilitate connection to other elements, e.g. at the corner of a web stiffener to clear the radiused fillet of a rolled beam section or at the weld of a fabricated beam.
<b>crosshead</b>	The 'head' of an intermediate support (pier), on which the bearings beneath the main girders are seated. Alternatively, use is sometimes made of an <b>integral crosshead</b> - a crossgirder (usually heavy) joining a number of main girders and under which bearings are located (between the main girders and fewer in number), each seated on a separate column.

# Guidance Note

## 1.01

---

TERM	DEFINITION
<b>deck</b>	Strictly, the 'floor' of a bridge, but, for highway bridges, much more usually: The superstructure of a bridge, comprising longitudinal beams, transverse beams or bracing and either a reinforced concrete slab or a steel <b>orthotropic plate</b> (see below) to carry the traffic or services on the bridge.
<b>diaphragm</b>	A transverse bulkhead inside a box girder, to maintain its shape or to distribute concentrated loads or support reactions.
<b>erection</b>	The activities performed to set in place on site the structural elements of a bridge.
<b>erection piece</b>	A fabricated part of a girder that is a sub-division of a girder, which is too long to be fabricated and erected in one piece. The length and weight of the erection piece is chosen to suit handling and transport.
<b>execution</b>	Activities carried out for the physical completion of the construction works. For steel structures, execution includes <b>fabrication</b> and <b>erection</b> , as well as procurement. (See EN 1990, 1.5.1.11.)
<b>fabrication</b>	The activities performed to make structural elements from materials, products and consumables.
<b>faying surfaces</b>	The abutting faces between two parts of a connection. Usually applied to the interface of a preloaded bolted connection that transmits shear force between the parts (a <b>slip-resistant connection</b> ).
<b>fitted stiffener</b>	A web stiffener that is prepared at its end and fitted to the surface of the flange that it abuts in such a way that the gap between the two is small and that loads can therefore be considered to be transmitted in direct bearing. See GN 2.04
<b>flange</b>	The upper or lower tension or compression element (usually planar) of a beam or box girder. The corresponding element in an open web girder is known as a <b>chord</b> ; chords are formed of rolled or fabricated sections.
<b>flat</b>	Rolled steel section of rectangular cross section whose thickness exceeds one tenth of its width (210 5033)
<b>gauge length</b>	A datum length over which various properties (e.g. elongation at fracture, out-of-straightness, etc.) may be measured.
<b>girder</b>	An alternative term for a metal beam. Usually applied to a beam that has two flanges and a solid web. Girders may be rolled steel sections, but more commonly the term is applied to a fabricated <b>plate girder</b> or to a <b>box girder</b> . <b>Truss girders</b> (see below) and <b>vierendeel girders</b> (see below) are 'open web girders'.
<b>girder make-up</b>	The component parts that are connected together when a girder is fabricated. Usually expressed in tabular form on drawings as a list of plate sizes and principal secondary elements (intermediate stiffeners, stud connectors, etc.).
<b>half joint</b>	An in-line structural connection between two beams or parts of beams that is formed by notching both, the upper on one side and the lower on the other. The connection between the two allows rotation but not moment transfer; it transfers shear and sometimes axial load. Now rarely used.
<b>half-through</b>	A bridge configuration in which the level of the road surface or track is below that of the top flanges or top chords (usually below mid-depth of the beams) and there is no cross bracing between the upper flanges or chords. The bridge is usually a square U in cross section. See GN 1.10. By contrast, a <b>through bridge</b> has girders that are sufficiently deep that top bracing can be provided above the traffic.
<b>Integral abutment</b>	An <b>abutment</b> that is structurally integral with the <b>deck</b> . There is then no expansion joint between the abutment and the deck. (For types of integral abutment, see P356 and PD 6694-1.)
<b>HSFG bolt</b>	High strength friction grip bolt. The old term for what is now referred to as a <b>bolting assembly for preloading</b> (see above). HSFG bolts were specified to BS 4395.

TERM	DEFINITION
<b>ladder deck</b>	A configuration of two longitudinal main girders with cross girders spanning orthogonally between them and the deck slab spanning longitudinally between the cross beams. The steelwork arrangement is similar to that of a ladder.
<b>lamellar tearing</b>	The tearing of a steel element when subject to forces normal to the plane of its surface. See GN 3.02.
<b>lamination</b>	An elongated planar discontinuity in the material of a rolled plate or section.
<b>location plate</b>	(In railway bridges: ) A plate bolted to the support structure upon which a bearing is located and fixed; the plate distributes the load from the bearing to the support structure.
<b>longitudinal</b>	Usually applied to: The direction of span of the bridge, or to: The orientation of the greatest dimension in a structural element.
<b>machined surface</b>	A surface that is ground, planed, milled or otherwise mechanically prepared to a greater degree of flatness and smoothness than is obtained by rolling, flame cutting, shearing, etc.
<b>MPI or MT</b>	Magnetic Particle Inspection or Magnetic Particle Examination (used in EN 12062)- a process for detecting surface breaking or near-surface imperfections in steelwork, including welds, where the imperfection is visually highlighted by the use of a strong magnetic field and iron-filings in a carrier liquid.
<b>normalized</b>	Heat treatment of steel after rolling, or during rolling ( <b>normalized rolled</b> ). See GN 3.01.
<b>notch</b>	A cut-out in an element. Particularly applied to a cut-out in a steel element when the shape is such as to cause local stress concentration sufficient to reduce the fatigue performance or to increase the susceptibility to brittle fracture.
<b>notch toughness</b>	A representative measure of the toughness of steel to resist suddenly applied load; measured in a <b>Charpy test</b> (see above). See GN 3.01
<b>orthotropic plate</b>	A plate with different stiffness properties in the longitudinal and transverse directions. Usually applied to a steel plate stiffened principally in one direction, with widely spaced stiffeners or supports in the other direction.
<b>pier</b>	An intermediate support to a bridge deck. A pier may take the form of a wall (a <b>leaf pier</b> ) or a number of columns.
<b>plate</b>	Thin rigid flat metal product (210 5313)
<b>Q and T steels</b>	Quenched and tempered steel. See GN 3.01
<b>residual stresses</b>	Stresses locked into a steel element as a result of the production process. Such stresses may arise from differential cooling/shrinkage rates during rolling (particularly in rolled sections), from shrinkage of welds after deposition, or from cold forming (bending plastically to achieve a required shape).
<b>shear connector</b>	A connecting device to transmit shear; the term is usually applied to a connector between a steel beam and a reinforced concrete slab. The most commonly used form of connector is a forged headed <b>shear stud</b> (see EN 1994-2).
<b>shrinkage</b>	In steel: The reduction in dimension when steel cools after being heated. In concrete: The reduction in dimension due to decreased moisture content that occurs after the concrete has been cast.
<b>slip resistant connection</b>	A connection using preloaded fastener assemblies (bolts) in which shear between <b>faying surfaces</b> is transferred in friction, achieved by the clamping action of the fasteners. Formerly know as a high strength friction grip (HSFG) connection. See GN 2.06.
<b>snipe</b>	A cut-off corner (usually a 45° triangle cut off a square corner). Sometimes used to form a <b>cope hole</b> (see above) at an internal corner.

# Guidance Note

## 1.01

---

TERM	DEFINITION
<b>splice</b>	An in-line connection between two elements formed by overlapping, usually involving secondary elements connected to each primary element. The secondary elements are termed <b>splice plates</b> or <b>cover plates</b> . Most commonly these plates are bolted, but they may be welded.
<b>stiffener</b>	An element attached to a planar steel element that increases its stiffness to out-of-plane deformation. A stiffener is usually linear in form, either of <b>open section</b> (e.g. a flat, an angle or a Tee) or of a <b>closed section</b> (V- or U-shaped, connected along both edges). Stiffeners may be either longitudinal or transverse to the element that they stiffen.
<b>through thickness properties</b>	Deformation properties of the steel perpendicular to the surface; these are often different from those in the direction of the plane of the surface. GN 3.02.
<b>TMR steels</b>	Thermomechanically rolled steel. See GN 3.01.
<b>tolerance</b>	Permissible variation of the specified value of a quantity.
<b>transverse</b>	An orientation at right angles to the longitudinal dimension of a structure or structural element. (For a web plate in the vertical plane, transverse may be taken as vertical if it is close to being at right angles.)
<b>trimmer</b>	Usually applied to: local stiffening or support at the end of a reinforced concrete deck slab, either by means of a transverse beam or by local thickening of the slab. See GN 1.03. Also applied to edge beams in heavily skewed bridges into which beams square to the abutment are connected.
<b>truss girder</b>	A girder formed by a triangulated arrangement of chord members (in place of flanges) and diagonal and (sometimes) vertical web members. Sometimes termed an 'open web girder'.
<b>UT</b>	Ultrasonic Testing - a process for detecting sub-surface imperfections in steel materials, including welds, by the use of ultra-sound pulse generation and response, usually with a visual display. See GN 6.03.
<b>vierendeel girder</b>	A girder made from chord members (instead of flanges), with discrete web members at intervals between the chords, square to at least one of the chords.
<b>weather resistant steel</b>	Steel material with a chemical formulation such that it corrodes to produce a thin, tightly adherent, impermeable, coating on exposed surfaces, obviating the need for further protective treatment. See GN 1.07.
<b>web</b>	The (usually vertical) element of a beam or girder between the flanges (or chords) that resists shear deformation of the beam.
<b>web stiffener</b>	A structural element limiting the size of a web plate panel in a beam or girder. An <b>intermediate web stiffener</b> is a transverse stiffener used to control out-of-plane buckling of the web. A <b>bearing stiffener</b> is used to control buckling and to form part of the load path from the girder to the bearing. See GN 2.04.
<b>welding</b>	A process of joining (steel) materials by fusing the edges/sides together by applied heating, usually with additional filler metal and flux, under a protective gaseous envelope. <b>For definitions of welding terms see BS 499-1 and EN ISO 17659.</b>
<b>wide flat</b>	Steel plate that is rolled to a specific width (up to about 650 mm) so that it may be used as a flange without any longitudinal cutting to size. No longer produced.

### References

1. *The whole of BS 6100 is published as a single hardback volume: Glossary of building and civil engineering terms*, Blackwell, 1993.
2. EN 1990:2002, Eurocode: Basis of structural design.
3. EN 1994-2:2005 Eurocode 4: Design of composite steel and concrete structures. General rules and rules for bridges.
3. BS 499-1: 2009, Welding terms and symbols. Glossary for welding, brazing and thermal cutting.
4. EN ISO 17659:2004 Welding. Multilingual terms for welded joints with illustrations





### Scope

This Guidance Note relates principally to the design and construction of deck-type and half-through skew bridge decks. Deck-type bridges, which comprise steel girders supporting a composite concrete slab at the top flange, are most frequently used for highways, whilst half-through decks are commonly used for railway bridges.

For the purposes of this Note, a skew bridge is one where the longitudinal axis of the bridge deck is not square to the lines of its supporting piers and/or abutments. In the Note, the skew angle is taken as the angle between a line square to the supports and the longitudinal axis of the bridge. Thus the greater the skew angle, the higher (or more severe) the skew.

Curved skew bridges are not covered.

### Main steelwork system

Deck-type construction is common for highway bridges and is used for some railway bridges. In continuous bridges of this type, the main girders are usually arranged parallel to the longitudinal axis of the bridge, even for high skews.

At the intermediate supports of continuous bridges, the girders can be supported either directly, by individual bearings beneath each girder, or indirectly, with the bearings providing support to integral crossheads that frame into the longitudinal girders. In 'ladder' decks,

internal supports will usually be directly under the main girders.

Some typical arrangements for deck-type multiple spans are shown in Figure 1.

With continuous spans, variable depth or haunched girders are generally best avoided for skews over about  $25^\circ$ , because of the geometrical complexity of the bracing.

On single span deck-type bridges, the main girders are usually arranged parallel to the longitudinal axis of the bridge when either:

- the skew is less than  $45^\circ$ ; or
- the deck is narrow in relation to its span.

On a narrow single span bridge with a pair of main girders spanning in the direction of the bridge axis, consideration should be given to squaring up the ends of the deck. This is particularly relevant for railway bridges, to avoid track twist.

However, when either:

- the skew is more than  $45^\circ$ ; or
- the deck is wide in relation to its span,

the main girders are more often arranged to span square to the abutments. In the case of a wide deck, the main girders will span directly between the two abutments over the centre part of the deck. Edge girders are provided, generally parallel to the longitudinal axis of the bridge, to support the other main girders so

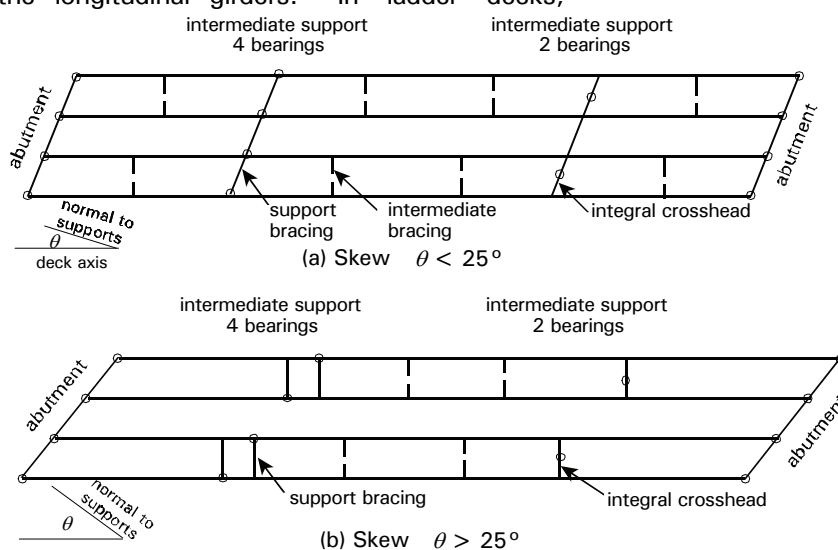

Figure 1 Arrangement of girders for deck-type multiple skew spans

# Guidance Note

## No. 1.02

that they span from the abutment to an edge girder. The main girders are usually framed into these edge girders with a rigid moment connection.

Typical arrangements for deck-type single spans are shown in Figure 2.

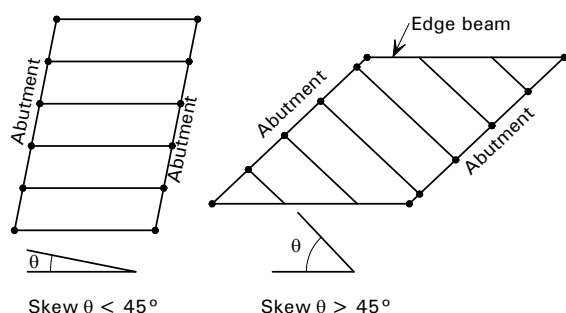

**Figure 2** Arrangement of girders for deck-type single spans

### Half-through bridges

For railway bridges in particular, the depth available for construction may dictate that half-through composite construction is used, with cross girders spanning between two main girders located at the edge of the deck. The cross girders may be partly or wholly encased in a concrete slab. When a steel deck plate is used, the transverse 'ribs' are arranged in the same manner as described below for cross girders.

For skews up to  $25^\circ$ , the cross girders can be either parallel to the abutment (termed skewed cross girders) or orthogonal to the main girders. When the cross girders in the centre part of the span are arranged orthogonal to the main girders, at the end of the span the cross girders nearest the abutment may be fanned to the trimmer beams (termed fanned cross girders).

For skews greater than  $25^\circ$ , the cross girders are better arranged orthogonal to the main girders, and skew trimmer girders spanning between the ends of the main girders are provided at the abutments to support the ends of the cross girders (an arrangement termed trimmed cross girders).

Typical arrangements for half-through railway bridges are shown in Figure 3.

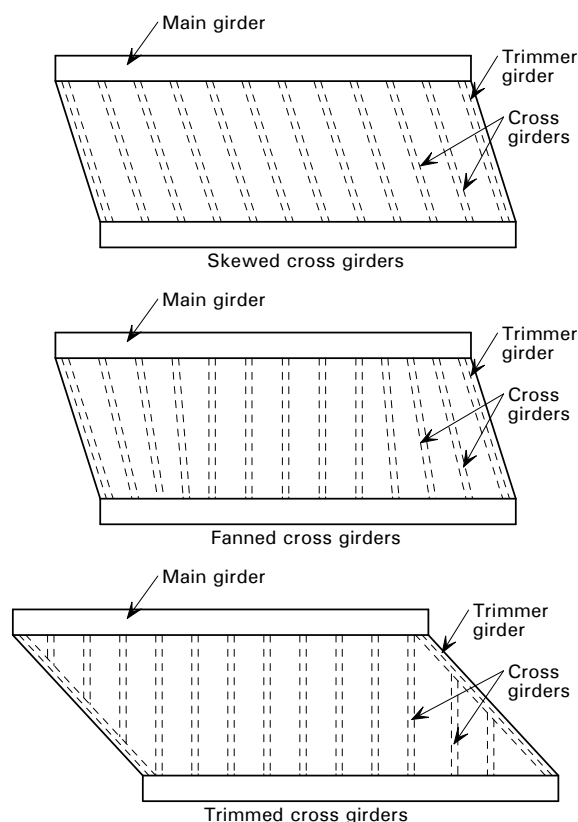

**Figure 3** Arrangement of girders for half-through railway bridges

### Bracing in deck-type construction

In deck type construction, for skews up to about  $25^\circ$ , intermediate bracing can be either parallel to the line of the abutment bearings (termed skew bracing), or orthogonal to the main girders. Intermediate bracing will usually only be needed to brace girders together in pairs rather than to provide a continuous line of bracing across the deck.

Skew bracing requires that the stiffeners to which it is connected are welded to the webs of the main girders at a skew rather than square. There is no particular advantage in making the bracing skew, except for link bracing between two braced pairs of main girders, where the bracings would otherwise be staggered in plan. For skews over about  $25^\circ$ , intermediate bracing is almost always arranged orthogonally to the main girders.

Irrespective of skew, bracing at the abutment supports is usually best arranged parallel to the line through the bearings. This bracing will also act as a trimmer beam to the deck slab.

At the internal supports of continuous decks where the skew is small (typically less than 25°), the bracing is also usually arranged parallel to the line through the bearings. For higher skews (over 25°) there are no hard and fast rules, and the bracing for each individual bridge should be tailored to the particular circumstances. Geometry, erection method and deflections (including twist) must all be considered.

Plate girder integral crossheads are often used at internal supports. Integral crossheads are usually arranged orthogonal to, and frame into the longitudinal girders. They may either join the main girders in pairs, or be continuous between girders across the width of the deck. Where the main girders are joined in pairs over a single bearing at the internal support the integral crosshead effectively acts as a bearing support diaphragm. See GN 2.09 for guidance on integral crossheads.

In multiple-girder bridges it may sometimes be appropriate to make the lateral system continuous across all the main girders rather than brace the girders in pairs. This is because continuous bracing participates in the transverse distribution of load, the more so with increasing skew. As the skew increases, cross girders of a size similar to that of the main longitudinal girders may be needed (see Reference 1).

#### **Vertical profile**

Particular attention should be paid to bridges with a vertical profile that has to follow a vertical curve, as a different geometry is required for each of the longitudinal girders. This, together with any crossfall, will also lead to differing geometry in the elements of the bracing system. For railway bridges there may also be a requirement to superimpose a live load precamber on the vertical profile of the girders.

#### **Girder twist**

At the abutments or end supports of bridges having high skews (typically 45° or more) where the main girders are interconnected by the deck or by intermediate bracings, the deck will tend to rotate about the line through the bearings. This mode of rotation will also occur during slab construction, once the main girders

have been interconnected by bracing, and will cause the main girders to twist. This twist effect is explained in GN 7.03. The resulting out-of-verticality of the girders should be taken into account in the design. Note that whilst EN 1090-2 (Ref 2) Table D.1.1 requires that for I girders without bearing stiffeners, the out-of-verticality of the web at the supports is limited to depth/200 but not more than the web thickness, the Model Project Specification (Ref 3), clause 11.101 (iv) specifies tolerance at completion on verticality of main girders at supports of depth/300 .

A pre-set twist can be built into the girders so that after deck concreting, the verticality of the web will be within tolerance. The designer should determine the pre-set twist necessary to counteract the twist that will occur. When the bridge is constructed, this pre-set can be achieved on site either by designing the permanent bracings with appropriate geometry, or in unbraced girders by twisting them at the support during erection. On the drawings, the pre-set twist should be illustrated as a rotation angle of departure from vertical and given in tabular form if twist varies at different locations.

The tendency of the deck to rotate about the line of the abutment bearings must be taken into account in the choice of the type of bearings and their axes of rotation. With elastomeric or pot type bearings, which allow rotation about all axes, no special consideration is required. However if linear roller or rocker bearings are needed to provide restraint against lateral rotation of the girder, the alignment of the axis of the bearing is an important consideration.

With half-through railway bridges, the bearings at the obtuse corners may need to be set relative to those at the acute corners to facilitate the erection of the cross girders.

Twist also has implications for the temporary works. In particular it is necessary to consider restraint to the main girders to prevent lateral torsional buckling. Experience during erection has shown that the actual movement that takes place is frequently less than that predicted by the designer.

# Guidance Note

## No. 1.02

---

Designers should consider every bridge with a skew greater than 45° as a special case, and determine the most appropriate method of dealing with twist.

### Deck slab

EN 1994-2 (Ref 4) 6.6.6 requires that the design of the transverse reinforcement in the deck slab of a composite bridge should be designed for the ultimate limit state so that premature longitudinal shear failure between the slab and the girder or longitudinal splitting shall be prevented. Note that EN 1994:2 6.6.5.5 states that the maximum longitudinal spacing of shear connectors should not exceed the lesser of 4 times the slab thickness or 800 mm. Designers may wish to continue to observe the BS 5400 Part 5 (Ref 5) 6.3.3 maximum spacing of bottom transverse reinforcing bars not greater than 600 mm.

In deck slabs of composite bridges the most efficient arrangement is generally for the longitudinal reinforcement to be parallel to the main girders, and the transverse reinforcement to be at right angles to the main girders. In skew decks and away from the edge of the deck at the abutment, the slab effectively spans square between girders, so the arrangement with the transverse reinforcement at right angles to the main girders is the most efficient. This does, however, lead to complicated detailing of the reinforcement at the edge of the deck parallel to the abutment. Hence at small skews (less than 15°) it may be preferable to place the transverse reinforcement parallel to the abutments. This will result in little loss in efficiency (see Reference 6).

It is important that the spacing and positioning of the shear studs on the girder top flanges and the detailing of the transverse reinforcement in the slab are coordinated so as to avoid unnecessary clashes with the studs. Shear studs are usually detailed in rows orthogonal to the axis of the girder, but if skewed reinforcement is preferred, the studs should be arranged on the skew to suit.

Where precast plank type permanent formwork is used for the slab, the planks are normally placed at right angles to the main girders. The spacing and positioning of the shear studs and the transverse reinforcement should be coordi-

nated with that of the planks. The triangles of slab without planks left at the edge of the deck at the abutments are usually cast using conventional formwork supported from off the abutment. Alternatively, though less commonly, precast 'specials' may be made to close these gaps.

### Detailing skew stiffeners

Care needs to be taken in specifying the size of welds between webs and skew stiffeners, as the dimension of the weld throat is dependent on the angle between the web and the stiffener. Reference should be made to EN 1011-2 (Ref 7):, Annex B, Table B.1. As skew increases, the ability of the welder to achieve root penetration on the acute side of the stiffener is impaired (see GN 2.05). Also with highly skewed stiffeners, access for bolting the bracing members needs to be considered in deriving the geometry of the stiffener.

### References

1. Bridged in Steel 12, British Steel.
2. EN 1090-2:2008 Execution of steel structures and aluminium structures - Part 2: Technical requirements for steel structures.
3. Steel Bridge Group: Model Project Specification for the Execution of Steelwork in Bridge Structures (P382), SCI, 2009
4. EN 1994-2: 2005 Eurocode 4 –Design of composite steel and concrete structures – Part 2: general rules and rules for bridges.
5. BS 5400 Part 5: 2005, Steel concrete and composite bridges. Code of Practice for design of composite bridges (now withdrawn)
6. Concrete, Feb 1968 and August 1968.
7. EN 1011-2:2001, Welding. Recommendations for welding of metallic materials. Arc welding of ferritic steels

### Scope

This Guidance Note gives advice on bracing systems for composite beam and slab bridges. The bracing described provides lateral or torsional restraint to the main beams and forms part of the load path in resisting lateral forces.

This brief note cannot provide a complete treatment of such a wide-ranging subject, and is intended purely as an introduction although the general principles are applicable to other configurations and forms of construction.

For further guidance on the restraint systems employed in half-through (or U-frame) bridges, see GN 1.10. For guidance on use of cross girders in ladder deck type bridges, see Ref 1.

### General

Most steel beams of rolled or fabricated I-section are potentially susceptible to lateral torsional buckling at some stage during erection; composite beams are also potentially susceptible to buckling where the steel flange is in compression. Susceptibility to these forms of instability is influenced by a number of factors, not least of which is the degree of lateral and/or torsional restraint provided at support positions and at intermediate positions on spans.

Bracing systems in any structure are 'secondary' elements, but their function is nevertheless vital to the performance requirements of the primary elements, both in service and during construction.

Both the stiffness and strength characteristics of restraint systems are critical from the point of view of providing 'adequate' or fully effective restraint.

In single span composite bridges, with the slab on top of the beams, the bracing required for the service condition is solely necessary for providing torsional restraint at supports. Further bracing may be incorporated to stabilise top flanges in compression during construction, particularly during casting of the deck slab – see *Bracing for Construction* below. In the case of continuous composite spans some permanent bracing may also be required adjacent to intermediate supports to

stabilise the bottom (compression) flange against lateral buckling.

Typical bracing arrangements in plan, for a bridge that has 'almost square' spans (i.e. skew less than about 20°) are shown in Figure 1. The considerations for each type of bracing are discussed below.

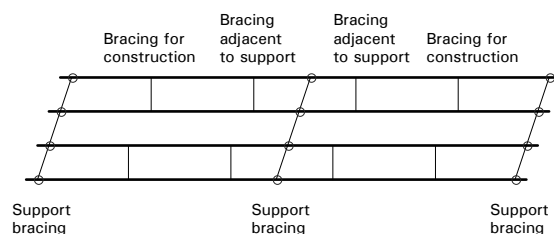
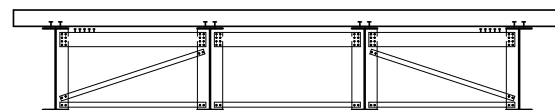

**Figure 1** Types of bracing to main beams of a composite beam and slab deck

### Bracing at supports

Bracing at intermediate and end supports is required to provide torsional restraint to the girders and to effect the transfer of lateral forces (e.g. collision loads) from deck level to the bearings. The bracing system may also offer vertical support to the end of the deck slab, for example by providing a trimmer, or transverse member below the end of the slab that gives it vertical support along its edge.

Where the bracing system also provides support to the slab, it should be continuous across all the girders. See Figure 2.



**Figure 2** Support bracing with trimmer beam

Support bracing can be provided simply between paired girders (i.e. with no connection between adjacent pairs), provided that the bracing can transmit lateral forces to whichever of the girders is restrained laterally by a bearing (and that the deck is capable of transferring all transverse forces to these girders). However, it is common to provide at least a tie/strut at bottom flange level between adjacent pairs.

### Intermediate bracing adjacent to supports

In continuous construction, the bottom flanges adjacent to intermediate supports are in com-

# Guidance Note

## No. 1.03

pression. Lateral restraint may be needed to ensure that buckling does not significantly limit the bending strength of the girders. This can be achieved either by the use of triangulated bracing, or by a stiff cross-member or inverted U-frame. See Figure 3 for examples.

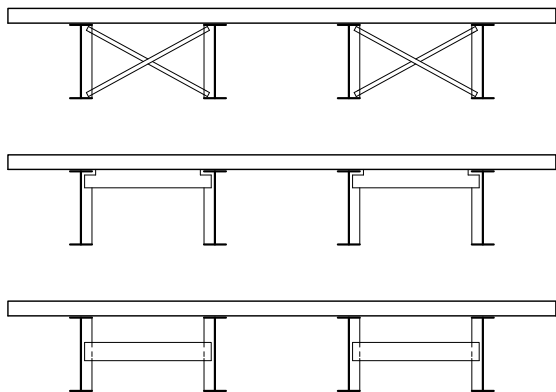

**Figure 3** Typical intermediate bracing adjacent to supports

Note that, in Figure 3, if there is a tie with the X bracing, or if there is a bolted connection at the crossover, it may also act as torsional bracing during construction. Stiff transverse members require moment-resisting connections to the main girders.

When the skew is less than about  $20^\circ$ , intermediate bracing can be positioned on the skew, parallel to the lines of supports, or it can be square to the girders (in which case the 'panel lengths' of adjacent girders are slightly different - see Figure 1).

Girders should normally be braced in pairs (but without any bracing between adjacent girder pairs). Continuity is not necessary, as if the bracing were continuous it might lead to fatigue problems because of the transverse loads induced in the bracing members and connections.

Even with paired bracing, fatigue effects need to be checked at bracing positions; with such bracing the most critical areas are those at the tops of the stiffeners, where significant bending can be induced by wheel loads on the deck slab.

### Bracing for construction

The staged construction of composite bridges usually demands more extensive bracing, to

stabilise the primary members before the deck slab is complete, in addition to the bracing needed for the service condition.

The designers of the permanent bracing and the temporary works bracing both need to consider risks to health and safety, as required by the CDM regulations (see GN 9.01). In particular, the permanent works designer needs to check the overall structure for stability both in the in-service condition and during construction. The designer might, for example consider the use of larger top flanges to reduce the amount of temporary bracing, or to achieve stability of individual girders under their self weight (avoiding the need for temporary measures to stabilise them).

In mid-span regions, the steel top flanges are in compression. Without lateral restraint during construction, these flanges would often be too slender to carry any significant load (not even their own self weight in many cases). Restraint to flanges can be provided either by transverse 'torsional restraints' between paired girders or by triangulated plan bracing.

The most economic form of bracing is usually torsional bracing, as shown in Figure 4. This configuration can have the horizontal at bottom or top flange level, although the latter may restrict fixing of formwork (keep the tie at least 100 mm below the slab).

Where only torsional bracing is provided (i.e. bracing between adjacent beams in a vertical plane), calculation of the effective length, and hence slenderness, is not simple during construction when the deck slab is not present. A computer model is likely to be needed to calculate  $M_{cr}$  (the elastic critical buckling moment) and hence the slenderness in such cases. **The effective length is usually not the distance between torsional braces, but a greater length.**

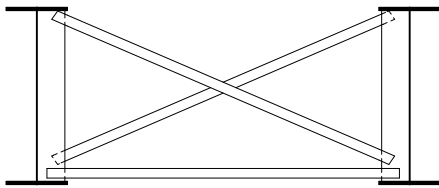

**Figure 4** Typical 'torsional bracing' between paired beams for erection

Other common configurations are Z (two horizontals and one diagonal) and K. K bracing is effective only if the horizontal is very stiff or if it is tied by a second horizontal.

Bracing that is required only for construction purposes may be removed once construction is complete if it impedes maintenance operations or adversely affects the performance of the bridge in service. However, it is often safer and cheaper to leave the bracing in place; consideration then needs to be given to the implications on maintenance operations if left in place and the risks associated with removal. If left in place, the bracing members and their connections need to be designed for fatigue effects and the members should receive the same corrosion protection as the remainder of the steelwork.

Whenever bracing for construction is to remain as part of the permanent structure, it must be connected by means of preloaded slip-resistant bolts, as for any other part of the Permanent Works.

As an alternative to torsional bracing, plan bracing can be provided at top flange level. Such bracing can be positioned within the depth of the slab, so that is completely surrounded and protected by the slab when it is cast. Such positioning is very effective, but it complicates fixing of slab reinforcement and should normally be avoided. Plan bracing just below the slab can cause even more difficulties, as it interferes with falsework support and has either to be removed or to be protected and maintained. Removal is hazardous once the slab is in place as the bracing cannot be supported from above while the bolts are being undone.

If girders must be erected singly, temporary bowstrings can be used to provide the neces-

sary compression flange restraint until the girder is connected to other restraints. (A bowstring is an arrangement of transverse struts and longitudinal tensioned wires that provides extra stiffness to transverse displacement.)

In longer spans, simple struts inserted transversely between girders (or between pairs of girders) are sometimes needed to share wind loads between the girders until such times as the deck slab is capable of performing this function. These struts may be removed after construction, to facilitate maintenance and to avoid creating transverse continuity and thus possibly attracting fatigue problems. The comments above concerning removal of bracing apply equally to these struts.

Sometimes on longer spans plan bracing may be required (forming with the main beams a truss in plan), to resist transverse bending effects, chiefly those due to wind loading during construction. Plan bracing does, however, tend to be a nuisance, whether at top or bottom flange level and is therefore better avoided, if possible.

#### Skew bridges

Bridges where the support lines are skewed at more than about  $20^\circ$  from square call for special care when designing the bracing system. In such cases, intermediate bracing is best arranged square to the girders. Support bracing may also be best set square to the girders, as shown in Figure 5, but see further comment in GN 1.02.

Whether the support bracing is along the line of support or set square to the girders, there will be a consequent twist of the girders at the supports as the girders deflect under load. This is because the girders rotate in the planes of their webs; the effects are greater at end supports than at intermediate supports, because of the continuity at the latter. See more detailed discussion in GN 7.03.

Note that if bracing is set at a skew of more than  $30^\circ$ , the attachment of the web stiffeners at an acute angle to facilitate connection of bracing will complicate the welding detail, because of the acute/obtuse angles with the web (see further comment in GN 2.04).



# Guidance Note

## No. 1.03

---

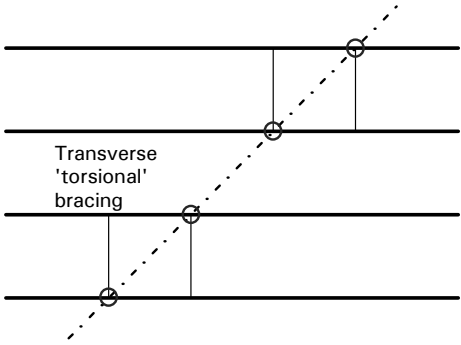

**Figure 5** *Typical support bracing arrangements for skew bridges*

**Reference**

- 1. Composite highway bridge design (P356), The Steel Construction Institute, 2009.

**Scope**

This Guidance Note gives advice on the selection of the articulation arrangements, the choice of bearing types and dispositions of bearings, for bridges where relative movement (translation and rotation) between the deck and supports is accommodated. Bridges that do not allow relative movement are known as 'integral bridges' - they are not covered here. Movable bridges (basculer, lifting, etc.) are also not covered in this Note.

Much of the advice is applicable to railway bridges as well as road bridges (unless otherwise noted), but designers of rail bridges should also refer to the particular requirements and guidance of the relevant railway authority.

See GN 2.09 for advice on ensuring that bearings are properly aligned.

**General**

Bridges are subjected to a variety of influences that cause displacement of the bridge deck and its supports. If these movements are resisted, forces will be generated within the structure. To control the development of restraint forces it has become normal practice to place the bridge deck on support bearings which allow some freedom of relative movement between the deck and supports. The arrangement of supports and freedoms of movement is known as the 'articulation'.

**Sources of movement**

Sources of movement include:

- temperature change (uniform and differential)
- shrinkage and creep of concrete
- dead load deflections/rotations
- traffic load deflections/rotations
- deflections/rotations due to horizontal loads (braking, traction, skidding, wind loads)
- settlement of supports
- earth pressure on abutment walls
- deflections of slender piers
- vehicular collision
- seismic effects (not generally in UK)

The design values of movements due to combined actions are determined in accordance with EN 1990. Characteristic values of actions are given by the various Parts of EN 1991. Forces on bearings and joints are calculated for the relevant design situations.

**Basic principles for good articulation**

A bridge can be articulated in one of a number of ways. The following principles should generally be followed:

*Minimise the number of bearings and joints by the use of continuous spans.*

The fewer the number of deck joints, the fewer the number of bearings and the less the opportunity for water to leak through and create potential durability problems. (The ultimate expression of this principle is to use 'integral bridges'.)

*Proportion the spans and detail the superstructure to ensure that uplift does not occur at a bearing under any load combination.*

*Choose an arrangement that provides simple restraint against longitudinal loads.*

Provide longitudinal fixity at only one support, unless the supports are flexible enough to allow sharing of longitudinal loads.

*Provide only one lateral restraint at each support, unless the supports are flexible.*

As well as unequal sharing of reactions, restrained bearings may restrain rotation of the beams about their longitudinal axes, thus inducing extra forces on the bearings.

*Anticipate the need during construction for temporary lateral restraint of individual girders*

Each girder, or pair of braced girders, will require temporary restraint. Choose the location of the permanent restraint to facilitate the temporary restraint.

*Consider at which end the bridge should be fixed*

In highway bridges, take account of the geometry and drainage provisions, to minimise the exposure of the major expansion joint to surface water flow. Rail bridges are ideally fixed (subject to abutment capacity) such that the beams are in tension under the dominant longitudinal force for the prevailing direction of traffic.

*Try to choose as the fixed or guided bearings those with the largest minimum vertical loads coexistent with the maximum horizontal load.*

Guided or fixed bearings with low minimum vertical loads are likely to require special designs and may be more expensive. Alternatively, use a separate guided bearing that does not carry vertical load.

# Guidance Note

## 1.04

---

### *Consider the effect of fabrication tolerances*

Consideration should be given to making an allowance for fabrication tolerances in calculating design values of positions and translations for the bearings - including systematic growth/ shrinkage of steelwork - see GN 5.03, Tolerances on length.

### *Avoid buried movement joints on steel bridges (unless spans are very small or there is an integral configuration).*

Larger rotations/deflections on steel bridges (compared to concrete bridges) can lead to early joint failures.

### **Horizontal restraint**

A continuous bridge needs only three horizontal restraints to be statically determinate. That can be achieved most easily by one longitudinal restraint and two lateral restraints, which can be arranged by having a fixed bearing at one end and a laterally restrained bearing at the other. All other bearings can be free. However, it is common to provide one guided bearing at each intermediate support to carry transverse loads (the structure is then a continuous beam in plan as well as in elevation). In a multi-girder bridge, the fixed and guided bearings would normally be under an inner girder, where there is always a significant co-existent vertical load.

Some designers consider it safer (because of greater redundancy) and more economic to assume that longitudinal load can be shared by more than one bearing, even by all the bearings on a bridge with four or more girders. However, it should be remembered that fixed or guided bearings may allow a movement of up to 2 mm (because of clearances in the bearing), and consequently it is probably unwise to assume equal sharing of horizontal loads. Also, in some circumstances (such as when the cross section tries to 'warp', because the rotations in elevation are different for each girder) opposing reactions can be developed without any externally applied horizontal load. Similarly, lateral restraint to more than two (closely spaced) girders would restrain 'distortion' (different rotations about longitudinal axes of the girders) and should normally be avoided.

Consider the following in positioning fixed bearings:

- can the substructure withstand the loads transmitted?
- do slender piers need to be laterally restrained at the top to reduce their effective length?
- if there is more than one fixed or guided bearing, is there sufficient flexibility to share loads?
- can structure/bearings withstand extra forces generated (e.g. due to expansion between two fixed bearings)?
- can the structure be fixed at the centre, to reduce movements at abutments and to balance bearing friction and associated restraint forces?
- can the structure span laterally between bearing restraints?

In addition, full consideration should be given to enabling erection to commence at the position of longitudinal fixity, thus avoiding the need to provide temporary fixity and the probability of having to jack assembled steelwork longitudinally to set the bearings correctly.

In some circumstances, it is desirable to share longitudinal forces between a number of supports, but without any loads being induced by thermal strain. In such cases, shock transmission units may be used; these can resist suddenly applied loads (e.g. braking and traction forces) but provide very little resistance to thermal movements (which occur very slowly).

### **Curved bridges**

On continuous curved multi-span structures, careful consideration must be given to the alignment of the guided bearings, to the consequences on movement at expansion joints and to lateral forces that may result from the constraint of the expansion of the curved configuration.

There are three basic alignments that may be considered:

- provide guidance such that the deck expands radially in plan from one fixed point
- provide guidance such that there is radial expansion and rigid body rotation in plan
- provide guidance such that the deck moves in plan tangentially to the curve of the structure at each bearing.

The first of the above arrangements means that at the end furthest from the fixed point the movements are at an angle to axis of the deck and thus the expansion joint has to accommodate displacements along its length as well as expansion/contraction. If the angle is large, this may be difficult to achieve.

The second arrangement overcomes the transverse displacement at the expansion joint by aligning all the guided bearings to achieve movement at the expansion joint along the bridge axis only. As this is achieved by some plan rotation, movements at intermediate supports are neither tangential nor radial, but will be at some angle in-between and different at each support. This will complicate definition of guided bearing alignment at these supports. A typical configuration is illustrated in Example 7 (Figure 7).

The third arrangement effectively guides the expansion around the original curvature by aligning all the guides tangentially to the curve.

This necessarily imposes lateral forces on the bearings (particularly those on the end spans at either end of the deck) and forces plan bending of the deck. A typical configuration is illustrated in Example 8 (Figure 8).

If the deck has a varying curvature along its length the third arrangement should be chosen because it is very difficult to permit free expansion at the same time as providing lateral restraint (against wind forces etc.) at intermediate supports. It would also be appropriate where the alignment includes a mixture of straight and curved lengths, but movements need to be carefully analysed (an expanding straight pushing into a tight curve may produce high loads on guided bearings).

### Skew bridges

On skew bridges, in general, set the direction of movement of bearings parallel to span, not perpendicular to support.

On highly skewed bridges, the movement parallel to the joint may exceed that perpendicular to the joint.

### Line rocker bearings

Line rocker bearings provide longitudinal and transverse restraint to movement; they provide no rotational restraint about the axis of the line

contact, but do provide rotational restraint perpendicular to that axis.

When considering use of line rocker bearings to provide torsional restraint to main girders the designer needs to take into account skew angle and span to width aspect ratio when determining the arrangement of the transverse members of the deck and/or the bracing between main girders. Line rockers would not normally be used with deck type bridges employing multi girder or ladder deck type steelwork systems.

Line rockers are often used, particularly in half-through U-frame bridges, to provide torsional restraint to steel beams at their support (see PD 6695-2, EN 1993-2 and EN 1993-1-5). However, significant moments can be induced on the bearings in such situations and line rockers should not be used where rotational restraint (about an axis square to the rocker) is effectively provided by other stiff components, such as diaphragms. In most cases, there are three choices:

1. Provide torsional restraint to the main beams through transverse beams or bracing and not use line rockers.
2. Use line rockers to provide torsional restraint and keep the stiffness of members transverse to the beam to a minimum, for example deck slab only (do not provide a moment connection between a deeper trimmer beam and the main girder). For small skews, the line rockers can be square to the beam or parallel to support line.
3. (More often used in half-through railway bridges.) Provide line rockers for torsional restraint and provide transverse beams that are either pin connected to the main beam or supported on their own bearings. The transverse beams then act as simply supported beams.

For a bridge with significant skew, line rocker bearings are usually inadvisable, because the twist deflections caused by the skew can produce particularly large moments on the bearings. However, for very large skew ( $60^\circ$  or more), line rocker bearings may be required at acute corners because it is difficult to provide





# Guidance Note

## 1.04

torsional restraint to those beams by any other method.

### Symbolic representation

It is common practice to indicate symbolically on drawings the different movements or restraints at each bearing. The representation should follow that of Table 1 of EN 1337-1, which also indicates bearing type. Examples are shown below. Only the pot bearings are used in the example arrangements; elastomeric bearings might be used for smaller bridges.

Symbol Type	Symbol Type
 Pot bearing (movements restrained)	 Elastomeric bearing
 Pot bearing with uni-directional sliding part	 Elastomeric bearing, restrained in one direction
 Pot bearing with multi-directional sliding part	

### Examples of articulation arrangements

Eight examples are presented, each with brief comments, illustrating typical arrangements and the use of the symbols.

#### Example 1: Simply supported road bridge



Figure 1 Arrangement for example 1

The composite deck has multiple steel girders; only three are indicated, for simplicity.

The fixed and guided bearings are on the same beam, to avoid problems with alignment of the guided bearing.

The fixed and guided bearings are on a centre beam to reduce transverse movements, but they could be on an outer beam.

#### Example 2: Two span continuous road bridge

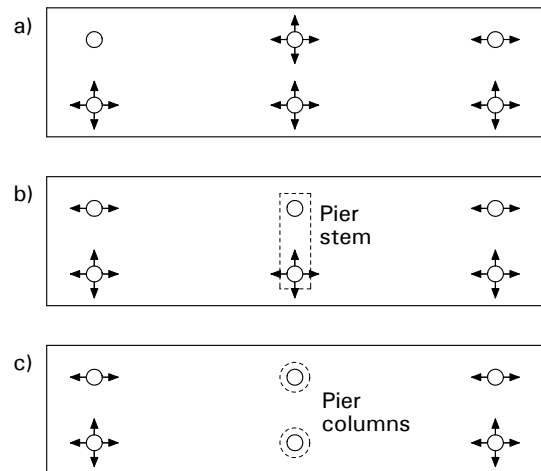

Figure 2 Arrangement for example 2

Three alternative arrangements are shown:

a) can be used if there is no horizontal load on the pier, other than friction.

b) can be used to reduce maximum movement, the pier resisting deck longitudinal forces.

c) can be used if there are slender pier columns needing restraint, the piers resisting deck longitudinal forces and accommodating transverse expansion forces

Railway bridges are typically single spans of half-through construction, with two main beams, one at each edge of the deck.

#### Example 3 Typical single span railway bridge



Figure 3 Arrangement for example 3

For square span railway bridges, the bearings under both beams are usually fixed at one end of the bridge. The bearings at the other end are guided, to ensure that movement of the bridge is parallel to the tracks. Movements transverse to the tracks are usually insignificant.

*Example 4 Typical skewed road or railway bridge*



**Figure 4** Arrangement for example 4

For skew bridges, the usual configuration is for the bearing at one corner to be fixed, the bearings at the two adjacent corners guided and the other bearing free (see Figure 4). All four bearings supporting half-through deck type beams should allow for rotation about a longitudinal axis (parallel to the main girders), unless allowance is made in the design for the higher loads on the inner side of the bearings, due to the rotation of the beams under load. These higher loads are most significant for railway bridges.

*Example 5 Heavily skewed railway bridge*

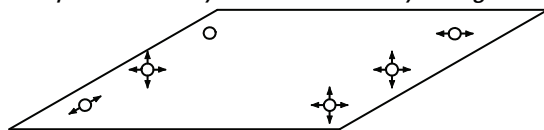

**Figure 5** Arrangement for example 5

For heavily skewed railway box girders in accordance with the standard bridge design, additional supports may also be provided under the trimmer girder. The bearings of such sup-

ports are usually free at both ends of the bridge.

Multiple span road bridges involve more extensive articulation arrangements.

*Example 6: Multi-span continuous*

There are four possible arrangements (see Figure 6):

a) may be used if longitudinal loads can be resisted at the abutment

- this leads to the largest bearing movements (at the far end)
- intermediate guided bearing(s) are needed if the deck cannot span laterally between abutments

b) reduces the maximum movement compared to (a)

- a strong pier is required at the fixed bearing to resist the longitudinal loads.
- the deck acts in plan as a two-span beam.

c) If the pier columns are flexible laterally, each bearing may be guided; if the central columns are strong enough, they may provide the longitudinal restraint, as in (b).

d) If the central piers are tall and flexible, they may share in providing longitudinal restraint.

Note that in (c) and (d) the columns are restrained transversely at the top by the deck.

# Guidance Note

## 1.04

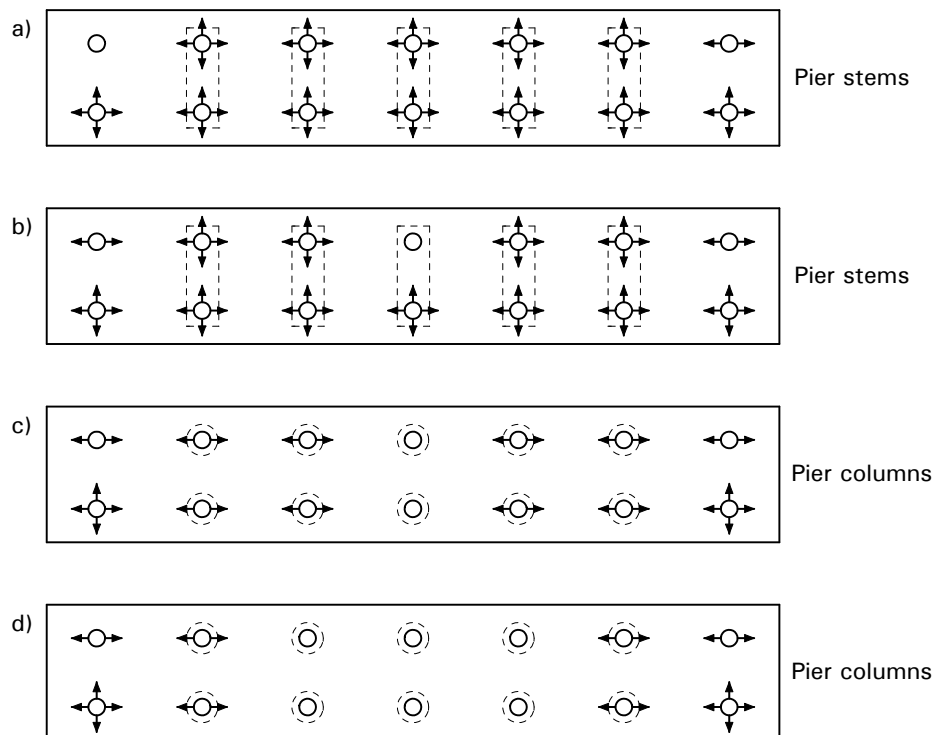

**Figure 6** Arrangements for example 6

### Examples 7, 8 and 9

The deck for these three alternative articulation arrangements is an indicative example of a three-span curved bridge with two bearings at each support. For multi-girder bridges, there would usually be four or more bearings at each support.

In the first arrangement, shown in Figure 7, the guided bearings are aligned radially from a fixed bearing at one abutment. This arrangement has the distinct disadvantage that the expansion joint (at the opposite end from the fixed bearing) must accommodate both normal and transverse displacements.

The second arrangement (shown in Figure 8) aligns each of the guided bearings at an angle  $\theta$  to the radial line from the fixed bearing, such that the movement at the expansion joint is guided to be only in a direction normal to the joint. The angle  $\theta$  is the same at all guided bearings and is the angle between the radial line from the fixed bearing to the guided bearing at the expansion joint and the normal to the joint (i.e. to the end of the deck). Expansion and contraction in this arrangement results in rigid body rotation in plan, as well as change in length.

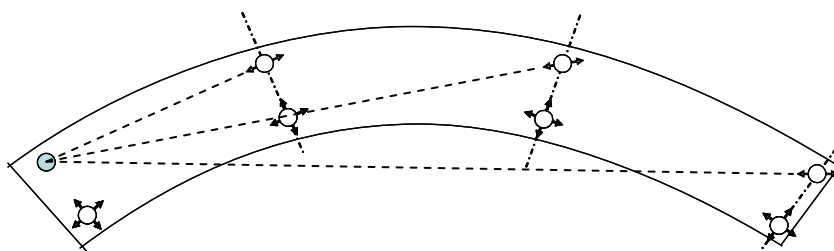

**Figure 7** -Curved deck with radial articulation

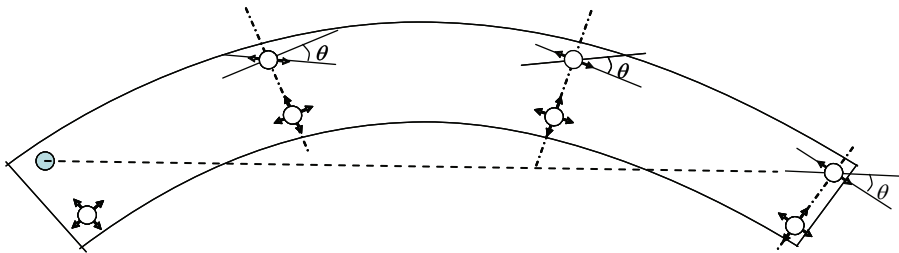

**Figure 8** *Curved deck with articulation for normal movements at expansion joint*

The third alternative articulation for the curved deck is shown in Figure 9. At each pier and at the abutment remote from the fixed bearing, the guided direction follows that of the longitudinal axis of the bridge at that point. Thus the expansion/contraction is forced to follow the curve through the guided bearings and in so doing, the deck is forced to bend in plan

(because, if free to expand, the radius and curvature would increase/decrease at the same rate as the change in length). This articulation arrangement is very easy to specify and install (there is less scope for confusion when aligning bearings than in the arrangement in Figure 8 but the constraint results in forces normal to the guided direction).

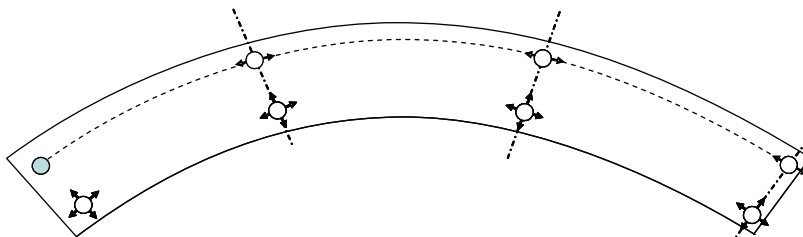

**Figure 9** *Curved deck with movement guided tangentially to the curve*

#### References

1. Lee DJ, Bridge bearings and expansion joints, 2nd edition, E & FN Spon, 1994.
2. Ramberger G., Structural Bearings and Expansion Joints for Bridges, IABSE Structural Engineering Documents 6, 2002
3. EN 1990:2002 Eurocode: Basis of structural design
4. EN 1991: Eurocode 1: Actions on structures (in numerous Parts)
5. PD 6695-2:2008, Recommendations for the design of bridges to BS EN 1993
6. EN 1337 Structural bearings (*in 11 Parts*)





**Scope**

This Guidance Note covers the structural arrangement of deck type composite bridges (concrete deck slab on top of steel girders). Whilst the Note is written principally with I-section steel bridge girders in mind, much of the information is also equally applicable where steel box girders are used for short and medium spans (see also GN 1.08). The information is presented generally in the order in which it will be considered during the course of the design.

**Bridge arrangement**

The designer will determine the span lengths of the bridge from consideration of the physical dimensions of the obstacle to be crossed, the required clearance envelopes, the available locations for the bridge abutments and intermediate piers (if more than one span) and aesthetics. The geometry of the crossing may require the bridge to be skewed (see GN 1.02).

Where there are three or more spans and the deck is simply supported at the end supports, end spans are normally proportioned to be 0.7 to 0.85 of the length of the adjacent interior span. With spans in this ratio, the end span sagging moment will be of similar magnitude to that in the adjacent span, and it is unlikely that there will be uplift at the end support.

For bridges of more than one span, variable depth girders may be used, although the saving in girder weight (at midspan) will usually only be significant for span lengths greater than about 40 to 45 m. On multi-span bridges with variable depth girders, care should be taken with the appearance. Whilst haunching the girders over the main span piers will give a satisfactory appearance, multiple haunched spans can be visually disturbing. Reference 1 gives guidance on the appearance of bridges.

Nowadays, with increased emphasis on durability and maintainability, unless particular circumstances such as mining subsidence warrant otherwise, multi-span bridges should be continuous over intermediate supports (see Ref 2 and GN 1.04). Steelwork for well de-

signed continuous decks will invariably be more economic than that for the equivalent simply supported spans. Continuity also offers robustness and redundancy in the event of damage to the supporting substructure.

**Number of girders**

The number of main girders in the deck cross section is determined principally by the required width of the deck and the economics of the steelwork. In composite construction the two arrangements that are most commonly used are:

- multiple parallel longitudinal main girders spaced at 3 to 4 m centres with the deck slab spanning transversely (see Figure 1)
- the 'ladder deck', comprising two longitudinal main girders with the deck slab spanning longitudinally between cross beams that are spaced at about 3 to 4 m centres (see Figure 2)

A span of 3.5 m is about the optimum for a 250 mm reinforced concrete deck slab and also allows the use of proprietary permanent formwork.

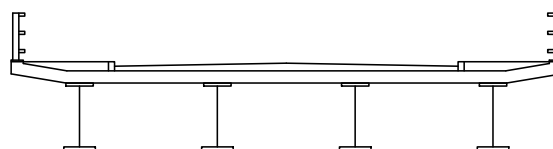

**Figure 1** Multiple girder bridge

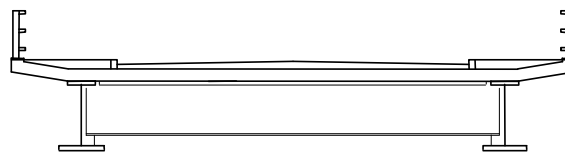

**Figure 2** Ladder deck bridge

Where there are limitations on construction depth, multiple girders with a closer spacing may be required, or, if depth is severely limited, through or half through types of construction may be utilised (see GN 1.10). Ladder decks usually prove to be economical for spans upwards of 35 – 40 m, and are best suited to bridge decks up to about 12 m in width. Good examples are found in References 3 and 4.

The ladder deck arrangement can prove cost effective on wider decks, although the load-

# Guidance Note

## No. 1.05

ing on the two main girders can become very heavy. Doubler plates may have to be used to provide flanges of the required size. Irrespective of the width of the deck, ladder deck girders will usually have a greater section depth than those in a multiple girder arrangement because the individual girders carry heavier loads.

On bridges with spans greater than 45 m and with wide decks, by spacing the main girders wider than 4 m apart and by haunching the deck slab, fewer girders can be used, and a significant saving in material in the girder webs can be made (see Figure 3). For spans in the range 80-100 m, plate girder composite decks of this form can be very economical where a ladder deck arrangement cannot be used.

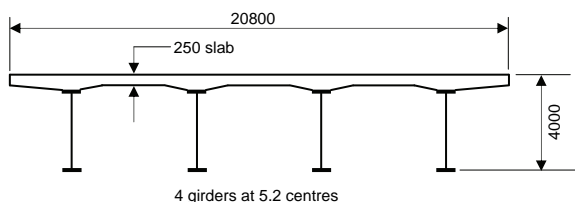
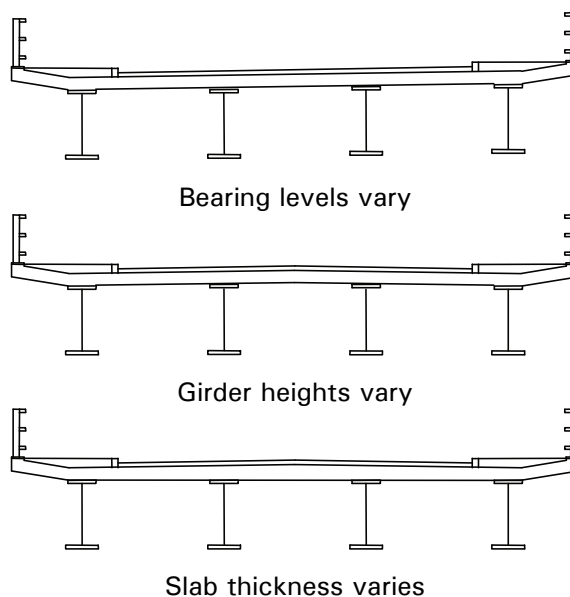

**Figure 3** Deck with haunched slab

Whichever arrangement is chosen for the deck cross section, careful consideration should be given as to how best to provide required crossfalls or superelevation. Most commonly the levels of the girder top flanges are set to define the soffit level of the deck slab, either by setting the bridge bearings to varying levels or by varying the girder heights. Less commonly, and usually only on smaller decks, the thickness of the deck slab is varied (see Figure 4).

With I-section girders the deck cross section will invariably have the girder top flange horizontal.

With box girders, it is usual to vary the web heights to provide the slope (see Figure 5). Sometimes the whole girder may be tilted so that the top flange is sloped parallel to the upper surface of the slab (this keeps the box geometry orthogonal, which may have advantages during fabrication, particularly of closed boxes).



**Figure 4** Superelevation and crossfall

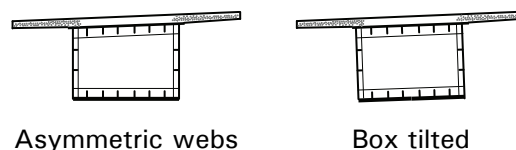

**Figure 5** Crossfalls on box girders

The designer should always bear in mind the method of erection. An even number of girders will facilitate erection in pairs by crane. If the steelwork is to be erected by launching, then constant depth girders are virtually a necessity.

There may be particular constraints at the erection site that limit the transport, handling and erection of the girders. In such cases the erection cost of a small number of heavy main girders may outweigh the savings in material cost over a greater number of smaller girders.

### Deck slab cantilever

With a multiple girder arrangement, the length of the deck slab cantilever will usually be about half the girder spacing. For both ladder deck and multiple girder arrangements, it is customary to limit the maximum length to not more than about 1.5 m for a 250 mm slab. A longer cantilever will require the deck slab at the cantilever root to be thickened, and with multiple girders will

result in the outermost girder being more heavily loaded than the inner girders. Generally, a short cantilever is to be avoided for aesthetic reasons and because the cantilever should have sufficient length to protect the edge girder from the elements. With a P6 high containment parapet, a short cantilever may, however, be unavoidable.

The designer should consider the stage at which the cantilever is to be constructed. From a construction point of view, casting the full width of the deck in one operation is generally preferred. This is usually done using a cantilever formwork system (see Figure 6) that is fixed to the outside face of the edge girder by bolting each temporary frame to a proprietary attachment that is welded to the upper surface of the top flange. The formwork system can be attached to the girder before erection, which is a particular advantage if the bridge has to be erected in a limited possession.

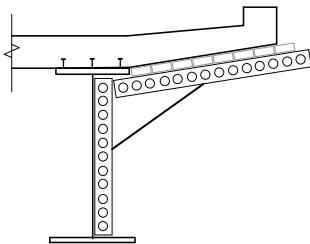
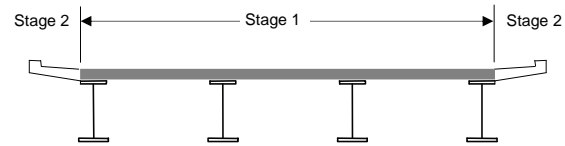

**Figure 6** *Cantilever formwork*

Alternatively, the cantilevers can be cast as a second stage, after the slab over the girders has been constructed and is acting compositely (see Figure 7). Note that the arrangement shown in Figure 6 will put a large torsion on the edge girder when the cantilever is concreted, and this torsional loading should be taken into account in the design and detailing of the bracing system.

A two-stage construction sequence is particularly advantageous for long cantilevers, as the cantilever wet concrete dead load is carried by the composite deck rather than by the edge girder in the bare steel condition. Also, with two stage construction, it is easier to obtain the correct line and level of the cantilever tip and stringcourse. If a two-stage sequence has to be used, this should be stated on the draw-

ings and provision for deflection allowance (precamber) made accordingly (see GN 4.03).



**Figure 7** *Two stage construction*

### Support to the deck

Generally, for a single span bridge deck the girders will be supported directly on the bridge abutment. A bearing is provided at each end of each girder, or in the case of integral bridges, the girders are built into the abutment wall.

Where there is more than one span the arrangement at the abutment will be similar to that for a single span and the girders will also be supported on the intermediate piers. Note that integral abutments are not appropriate where decks are either longer than about 70 – 80 m or skewed more than 30°.

With multiple girders the form of the substructure can be chosen so that either:

- each girder is supported on a bearing, usually in conjunction with leaf piers or, less frequently, on portal type piers or individual columns (see Figure 8)

*or*

- there are fewer bearings than girders; this requires the use of integral (or lost) crossheads (see Figure 9)

Use of integral crossheads with haunched girders can be unsatisfactory visually, because the point of the haunch appears to be unsupported. The combination of haunching and integral crossheads is best avoided, especially where the supports are skewed.

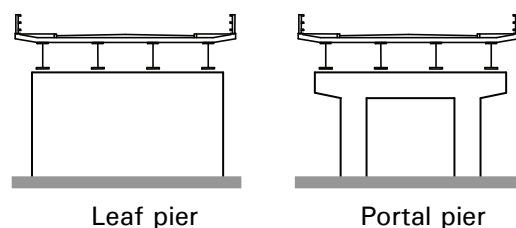
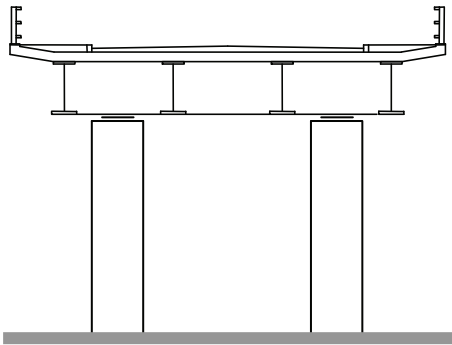

**Figure 8** *Leaf and portal piers (all girders on bearings)*

# Guidance Note

## No. 1.05

---

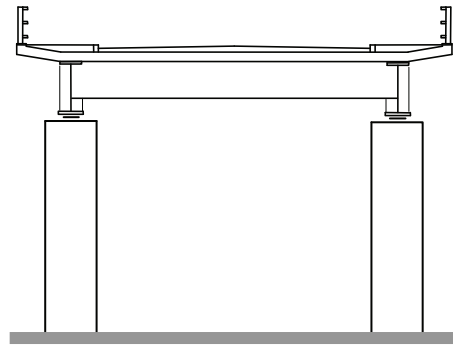

**Figure 9** *Integral crosshead*

Where integral crossheads are used, the stability of the steelwork during erection must be considered. If the girders are erected one at a time, temporary propping/support will be required. If they are lifted in pairs the integral crosshead can be landed directly on the supporting pier. Appropriate restraint against sideways rotation should always be provided.

For relatively narrow decks (usually with just two girders) a single column intermediate support is often preferred for aesthetic reasons. A single column support may also have to be used at a skew crossing where there is insufficient space to accommodate an orthogonal leaf type pier – for example in the central reserve of a dual carriageway. In such instances the designer should ensure that torsional loading is adequately distributed by the deck.

Usually with a ladder deck arrangement each of the girders is supported on a bearing seated directly on column type piers (see Figure 10) or, less frequently, on leaf type piers. With this arrangement the main girders can be landed directly on the supporting pier. The cross beams are usually erected and bolted once both main girders have been erected. A deeper cross beam or additional bracing will often be required at the support positions (see GN 2.03).



**Figure 10** *Typical ladder deck pier*

### References

1. BA 41/98 The design and appearance of bridges, Design Manual for Roads and Bridges, TSO, 1998
2. BA 57/01 Design for durability, Design Manual for Roads and Bridges, TSO, 2001.
3. The Structural Engineer, 1 August 1989
4. Bridged in Steel No 11, British Steel.

---

**Noise from steel and composite railway bridges** No. 1.06

---

**Scope**

This Guidance Note discusses the issue of noise from steel and composite railway bridges, provides general guidance on minimising noise emissions and gives advice on designing structures to meet acoustic requirements in a cost effective manner.

**Background**

At speed, the noise from trains is normally dominated by the interaction of the rail and the wheel. When trains run on bridges there is frequently an increase in noise levels. This increase usually appears as a low frequency rumble and is associated with the bridge structure radiating noise (often termed 'structure-radiated noise').

Steel railway bridges are perceived as noisier than those constructed using other materials. This is almost certainly based on experience of old steel bridges in which the problem had not been addressed during design.

Recent experience has shown that structure-radiated noise from a bridge is more of a function of the track-form used and, to a lesser degree, the bridge's detailed design than of the construction material used. The design of older steel bridges gave little or no consideration to the control of noise; the rails were often directly and rigidly fastened to the structure, providing a direct path for the vibration generated at the wheel/rail interface to pass straight through into the bridge structure where it is radiated as noise.

There is no reason why a modern, well-designed, well-detailed and well-maintained steel railway bridge with an appropriate low noise track-form should be any noisier than a railway bridge in any other material. However, noise control of both structure-radiated and direct airborne noise will need to be considered and the cost of any additional noise mitigation must be included when considering the economics of the whole system (track and bridge).

**Sources of noise from railway bridges**

It is important to identify the various sources of noise, before considering measures to minimise overall noise levels.

With the exception of noise generated by the train's traction and ancillary equipment and turbulence from high speed trains, which are independent of structural form, noise emissions from railway bridges arise from the two main sources, wheel/rail rolling noise and structure-radiated noise, as described below.

Both sources arise as a consequence of the train wheels rolling over the rail and the inherent roughness present on the running surfaces of both. The overall level of wayside noise is therefore strongly dependent on the roughness of the wheels and rails. Rail wear and particularly rail corrugation can significantly increase wayside noise (by 10 dB or more).

Similarly, rough wheels and wheel defects (such as flats) can also, on long bridges, increase wayside noise levels significantly. The effect of wheel flats can be particularly significant on lightweight long span steel bridges (generally where the bridge length is more than twice the length of the trains using it). In this case there is a risk that each wheel flat rail strike can generate a 'ringing' response from a significant proportion of the bridge. The overall structure-radiated noise thus becomes the sum of the noise generated by the general wheel/rail roughness and the series of 'ringing responses' to each wheel flat strike as the train passes over the bridge.

*Wheel/rail 'rolling noise'*

The excitation forces generated by wheel/rail roughness cause the wheels and rails to vibrate and hence to radiate noise. This noise source is independent of the structural form of the bridge. However, the noise level is dependent on the track-form and it should be borne in mind that the use of slab tracks (e.g. to avoid the dead load of ballast) can increase rolling noise levels by 3 dB or more. There are three possible reasons for such increase. First, the nature of slab track rail fastening and support systems means that, all other parameters remaining equal, the noise levels generated by the rail are greater than for ballast track. Second, ballast is effective at absorbing sound. This effect can be replicated with slab track by adding

# Guidance Note

## No. 1.06

---

acoustically absorbent treatment to the track slabs, although this can add significantly to capital cost. Third, the track slab or rail bearers can also be sources of noise (generated by wheel/rail vibration transmitted through the rail support to the slab or bearer). These matters need to be accounted for in the design of a low noise steel bridge.

### *Structure-radiated noise*

This is a complex phenomenon depending on many aspects of the design including the stiffness, mass, natural frequency, and damping of the bridge structure and hence its response to the forces generated at the wheel/rail interface. To reach the bridge these forces have to be transmitted through the rail support system. Hence the track-form design and its interaction with each type of train are fundamental to the levels of structure-radiated noise generated. Also important is the effective radiating surface area of a bridge. Generally the larger the surface area the greater the noise levels generated. Use of wayside noise barriers (e.g. as parapets) to control rolling noise (see below) can therefore increase the bridge's surface area and hence, without mitigation, increase levels of structure radiated noise.

Providing control of overall wayside noise levels therefore requires holistic, integrated design of the bridge, track and noise mitigation.

### **Characteristics of noise**

It is important to understand the characteristics of noise and how it is assessed.

The noise from a passing train may be considered to have the following basic characteristics:

- An 'average' maximum noise level as the train passes.
- The time taken for the train to pass.
- The frequency characteristics of the sound.

The 'average' maximum noise level is not the same as the instantaneous maximum noise level that may only occur for a short period. Rather, it is the average maximum level that occurs as the train passes the listener.

The noise impact for wayside receivers is dependent on the 'angle of view' (i.e. the length of railway) as seen by the receiver. If a bridge only occupies a small proportion of the angle of view, then it would have to be extremely noisy (compared to the adjacent sections of line) for it to significantly influence the overall wayside noise level. Hence, the fact that steel is often used for long span bridges that occupy a large proportion, or all, of the angle of view, means that the overall wayside noise levels are sensitive to increases in the noise caused by the bridge. This could also be behind the misconception that steel rail bridges are noisy.

The human ear is not equally sensitive to all frequencies, showing decreasing sensitivity at both low and high frequencies. The most frequently used method of assessing this complex behaviour is to apply what is called 'A-weighting' to the measured noise as this mimics the frequency response of the ear. Most noise limits and specifications applied to railways are couched in terms of A-weighted levels. However, there is evidence that A-weighted noise levels can under-estimate the human response to noise that is rich in low frequency content (e.g. where there is significant structure-radiated noise from a bridge structure). In these circumstances consideration should also be given to other noise metrics such as B- or C-weighted levels or 'loudness levels'.

### **Measures to minimise relative noise levels**

When designing a rail bridge to minimise noise emissions, the structure should have a high resistance to the vibrations imposed upon it. This resistance to vibrations, or input impedance, will limit the noise re-radiated from the structure.

Where a bridge is designed to the latest criteria for vibrations from high-speed trains (speeds over 125 mph) for structural or passenger comfort reasons, noise levels are often reduced. Thus, a modern steel bridge designed for high-speed trains is less prone to noise problems. However, where a bridge is in a noise sensitive location consideration does still need to be given to noise assessment and, if necessary, noise mitigation.

A number of practical measures are available to ensure that a steel bridge is no noisier than an equivalent railway bridge in any other material. These measures include (in sequence from source to receiver):

- Ensuring that the combined roughness of rail and wheel is as low as practicable. If this forms a part of a noise mitigation scheme then ensure that the feasibility of the additional maintenance (and operational cost) is included in planning the railway and its operation.
- Isolating the track from the deck to reduce structure-radiated noise. Do not connect the rails directly to the deck. Use sleepers on ballast where feasible and if necessary soft rail pads, sleeper soffit pads or under-ballast matting to provide greater isolation. Alternatively, if slab track is used, use resilient rail fastenings, booted sleepers or floating slab track as necessary, depending on the degree of isolation required. If slab track is used then take account of the increase in wheel/rail 'rolling noise' and hence increase the size of noise barriers as required.
- Providing noise barriers (e.g. as parapets) where sideways transmission of wheel/rail rolling noise is an issue. Make the inner (rail) side of the barriers acoustically absorbent if necessary. Evaluate whether the increased surface area provided by barriers increases structure-radiated noise and isolate the barriers from the bridge if necessary.
- Avoiding large, unstiffened and undamped steel plates and completely enclosed girder sections, where practicable.
- Minimising the height and length of girder webs (by providing a larger number of smaller girders) where practicable. Limit the lengths of web that are without stiffening and bracing.
- Designing the natural frequencies of structural elements to be, where practicable, outside the fundamental modes associated with the train/track interaction. Also, ensure that structural elements do not have the same natural frequencies as the narrow band excitation associated with sleeper, axle, bogie or carriage passage frequencies for the design speed(s).

- Considering the use of vibration damping steel plates for the webs of girders, particularly on half through type bridges. For example, a steel plate coated with bitumen, or a steel/resin/steel sandwich panel. Constrained-layer damping treatment can be very effective in terms of performance, but can be expensive and may need periodic replacement. 'Spot' mass damping (localised mass dampers placed at the main anti-nodes of the modes of vibration that contribute most to the radiated noise, usually the centres of plate panels) should also be considered and may be more economic.

### Designing to specified acoustic limits

Bridges for new railway lines are sometimes subject to planning requirements that restrict the noise emitted when a train passes. However, this is rarely the case for deck replacement schemes or for bridges in rural locations.

The analysis required to demonstrate satisfactory noise performance is detailed and requires significant expertise and resources. Hence, the unnecessary specification of noise limits should be avoided. Equally, for major bridges near to residential or otherwise noise sensitive areas, acoustic design and mitigation are essential and the costs should be allowed for.

Note also that such requirements should be a performance specification, which applies equally to all forms of railway bridge regardless of material.

### Analysis methods

A detailed model of the railway bridge needs to include, as a minimum, the unsprung mass of the trains, the track design and sufficient of the bridge structure as is necessary to be able to predict wayside noise levels (this may only need to be one or two spans).

For acoustic analysis and with modern rolling stock (most of which has soft primary suspension) the sprung mass of the rail



# Guidance Note

## No. 1.06

---

vehicles can be treated as being de-coupled from the bridge structure. However, the unsprung mass of the train will always need to be considered to evaluate the vibration isolation characteristics of the track-form.

It is essential to evaluate or measure wheel and rail roughness. These can be used in conjunction with a dynamic model of the train/track/bridge to evaluate the generation of the force inputs from the rail/wheel interaction. Alternatively where the bridge is rigid and massive (not generally the case for steel structures) the interaction forces can be determined using the track/wheel interaction model developed for at-grade ballast and tie track (known as TWINS). The TWINS model has been widely validated (for at-grade ballasted and tied track) and is commercially available from the European Railway Research Institute (ERRI).

The evaluated forcing function is then used as the input to a structural response package, of which two types are commercially available:

- Finite Element Model
- Statistical Energy Analysis

In either case, the models need to represent the bending waves up to 350 Hz in the bridge structure.

These approaches are used to evaluate the structure-radiated noise component only. The wheel/rail rolling noise needs to be evaluated separately and added to the structure-radiated component.

### *Finite Element (FE) Models*

FE models have been shown to be accurate but are very demanding on computer resources, and can take many hours to run even on the latest computers, which limits the ability to assess the impact of minor design changes. However, recent advances in finite element formulations, parallel processing and processor speed are largely expected to overcome this problem.

FE models for acoustic analysis are significantly more complex than the models used for structural design. A detailed knowledge

and experience of the realistic values that need to be applied to the many material and design parameters is also needed.

The FE models predict vibration on the surface of the structure. These vibration levels then need to be input to a second model (usually a boundary element model) which predicts the wayside noise radiated by the vibrating bridge elements.

### *Statistical Energy Analysis (SEA)*

With SEA, the structure is broken down into a number of subsystem elements (plates, beams & acoustic volumes) that are connected in a manner dependent on how it is considered bending, shear and axial waves will be transmitted between them. The model then uses the 'averaged' properties of elements and their connections to predict the 'average' flow of acoustical energy around the structure, which then leads to a prediction of noise and vibration levels in and around the structure. SEA is easier to use, permits the rapid assessment of design changes and hence is a useful tool at the concept design stage. However, there is a scarcity of input data for rail bridges, so there is a need to validate any predictions of absolute levels of noise and vibration.

SEA can address higher frequencies than FEM (i.e. beyond 350Hz) but is less accurate at lower frequencies.

### **Applications of acoustic design and mitigation methods**

There are various reasons for carrying out an acoustic analysis.

For example, there may be engineering practicability limitations associated with a lower noise non-steel solution (such as for a long span structure over water, road or rail). An acoustically acceptable solution would then have to be found using a steel or composite structure.

In this case, the capital and operational costs associated with noise mitigation may be very high (such as when long lengths of floating slab track appear necessary). Then, the commissioning of a detailed acoustic design

study may provide a means of identifying suitable acoustic mitigation at greatly reduced capital/operational cost (i.e. the acoustic design fees may be small compared to the difference in the capital and operational cost).

Similar economies of scale apply where a single concept design is being developed for short bridges that are to be used in many locations.

This type of methodology has already been applied to several new railway bridge and elevated structure designs in order to establish successfully:

- compliance with noise commitments in locations that are noise sensitive or where it is perceived from the outset that steel structures may be 'too noisy'  
*and/or*
- minimum cost solutions for achieving compliance with noise constraints.

### **References and further reading**

1. Reducing Noise Emission from Steel Railway Bridges (P173), The Steel Construction Institute, 1997.
2. Noise from Railway Bridges, Hardy A. E, Proceedings of the I Mech E, Part F Journal of Rail and Rapid Transit, 16 August 1999, vol. 213, no. 3, pp. 161-172(12).
3. A Validated CAE Method for Predicting Viaduct Structure-Borne Noise, Hargreaves, J.A. Internoise2000, August 2000, Nice, France



#### Scope

This Guidance Note gives brief advice on the use in bridges of weather resistant steel (often called weathering steel or, in CEN terminology, 'steels with improved atmospheric corrosion resistance').

#### General

Weather resistant steel is a low alloy steel that forms a protective oxide film or 'patina' that, in a suitable environment, seals the surface and reduces corrosion loss.

#### Reasons for use

Use of uncoated weather resistant steel may achieve the following benefits, relative to bridges with coated structural steelwork:

##### *Reduced first costs:*

- saves painting costs
- saves construction time

(The savings offset a slight increase in material cost)

##### *Reduced maintenance:*

- no need to repaint
- reduces traffic delays during maintenance
- not as dependent on weather conditions
- reduces need for access (especially beneficial where access is difficult, e.g. over a motorway, railway or river)

These savings can lead to reduced whole life costs.

#### Restrictions on use

Weather resistant steel is **not suitable** for the following environments:

- where there is an atmosphere of concentrated corrosive or industrial fumes. This may be defined as having a pollution classification above P3 to ISO 9223 ( $\text{SO}_2 > 250 \mu\text{g}/\text{m}^3$  or  $200 \text{mg}/\text{m}^2$  per day). See reference 20.
- where steelwork is continuously wet or damp (the protective layer does not form, and the steel rusts in the same way as ordinary carbon steel)
- where steel is exposed to high concentrations of chloride ions or salt spray. (This may be defined as an environment having a salinity classification greater than S2 to ISO 9223 ( $\text{Cl} > 300 \text{mg}/\text{m}^2$  per day) - see BD 7/01, Ref 16). Caution is therefore

needed when considering use within 2 km of a coast.

- where the use of de-icing salt is likely to lead to substantial deposits of chloride on steel surfaces, e.g. where salt laden water would flow directly over the steel or where salt spray from roads would settle under wide bridges when 'tunnel-like' conditions are created (see further comment on Page 6).
- where steel is buried in soil.
- where the headroom to steel over water is less than 2.5 m.

Note that weather resistant steel is **suitable** for overbridges at standard minimum headroom of 5.3 m.

#### Steel design

##### *Steel grade*

Steel should be specified to EN 10025-5 (Ref 14). There is another standard for structural hollow sections in weather resistant steel, BS 7668 (Ref 15), but this is seldom relevant due to the lack of availability of such products - see further advice on availability at the end of this Note.

##### *Loss of section*

- Allowance should be made for the formation of rust and the resultant loss of structural section over the life of the bridge.
- The thickness lost depends on the severity of the environment, and the following allowances for this loss are recommended:

Atmospheric Corrosion Classification (ISO 9223)	Weathering Steel Environmental Classification	Thickness allowance on each exposed face
C1, C2, C3	Mild	1.0 mm
C4, C5	Severe	1.5 mm

- Interior faces of ventilated boxes: allow 0.5 mm.
- Interior faces of sealed boxes: no allowance needed.
- All fillet welds and partial penetration welds should adopt the same allowance as the adjoining plate.
- No further allowance is needed for full penetration butt welds (already allowed in parent plates).

# Guidance Note

## No. 1.07

---

- The allowance should be made on all structural elements, including stiffeners, bracings, etc.
- No allowance should be made to weather resistant steel bolts.

### *Global analysis and stress analysis*

The analysis of the structure can be carried out using gross cross section properties, but stress calculations should be based on the net section after deduction of corrosion allowances.

### **Fatigue design**

Fatigue need not be of any more concern than with other structural steels. Although the small corrosion pits on a weather resistant steel surface would lead to a lower fatigue resistance in elements that are unwelded and free from holes and stress concentrations, the defects or imperfections inherent in welded details usually govern fatigue life. The corrosion pits on a weathered surface are smaller than weld defects and therefore do not affect the fatigue life. Although Table 8.1 of EN 1993-1-9 (Ref 21) 'downrates' the fatigue category for five unwelded details if the element is of weathering steel, the modified category is in most cases not less than the limit in Table NA.1 of the UK NA.

Additionally, the corrosion allowance provides additional reserve in the calculation of design life.

### **Detailing**

The detailing of weather resistant steel bridgework is essentially the same as for coated steelwork, except that the consequences of poor detailing are likely to be more severe in terms of poor durability and appearance. The following advice is particularly appropriate to bridges with weather resistant steel.

- Detail girders to encourage drainage. Avoid traps for moisture and debris (e.g. grind flush the top surface of all butt welds on the bottom flanges of beams, provide 50 mm radius cope holes where web stiffeners are attached to the bottom flange), and provide good ventilation.

- Ensure good access for inspection, monitoring and cleaning of debris, etc.
- If there are local areas that would be subject to especially severe conditions, specify local painting (although it is better to adopt measures to avoid severe conditions, if that is possible).
- Minimise the number of deck joints, ideally use continuous or integral construction.
- Where joints do occur, ensure access is good and ensure that a positive drainage system is provided, preferably of a non-metallic type.
- Locate joints such that leaks would not run down the steel face or stain materials that cannot be easily cleaned. Avoid concrete, galvanised steel, unglazed brickwork, stone and wood where there may be run-off.
- A sealant should be provided at interfaces between weathering steel and concrete.
- Avoid crevices, e.g. lapping plates, otherwise capillary action will occur and rust packing will distort or burst the connection.
- Ensure water/condensation will not form localised drips; this would cause pitting in the steel section.
- For slab-on-beam highway bridges, choose wide cantilevers with well-formed drips (this avoids staining of girder face and possible differential corrosion), although cantilevers in excess of about 2 m are more difficult to construct and are therefore rarely used.
- Avoid bi-metallic joints, which may promote local corrosion. Note that small components of 'more noble' metals (such as stainless steel bolts) are unlikely to cause problems. (For further comment on bi-metallic joints at bearings, see Page 6.)
- Measures to discourage public access to the girders should be considered to reduce the incidence of graffiti, which is difficult to remove.

Reference 10 gives some typical good and bad details.

**Drainage from weather resistant steel**

Ensure that run-off water from the steel surface cannot run down concrete faces (e.g. avoid crossheads that project beyond the outer edges of box girders).

- Provide generous falls to bearing shelves.
- Provide drip plates to collect or deflect water.
- Non-metallic outlet pipes from the deck should be of sufficient length to ensure that the discharged water does not spray onto the adjacent steelwork.

**Welding of weather resistant steel:**

EN 1090-2 requires in clause 7.5.10 that "Welds on steels with improved atmospheric corrosion resistance shall be carried out using appropriate welding consumables". These may be matching consumables, containing approximately ½% Copper and other alloy elements for Submerged Arc Welding (121, 122), Manual Metal Arc (111) and Metal Active Gas (135) processes. Alternatively, they shall be either 1Cr ½ Mo, or 2 Ni for 121 and 122 processes; or 1Cr ½ Mo, or 2½ Nickel for 111 and 135 processes.

The term 'matching' in relation to electrodes is a little misleading. In reality it means electrodes which will cause the welds to weather in a similar manner to the parent material.

However, it has been shown in practice that it is best to avoid the use of matching electrodes in some situations, because the resulting weld metal becomes copper-rich, and this can lead to difficulties if the weld is also restrained. Hence, the use of C-Mn consumables is recommended only for the following situations:

- Single run fillet welds up to 8 mm leg length using the processes 121 to 125, 135 and 136. (Note that with deep penetration, 8 mm leg length fillet welds provide the equivalent strength of 'ordinary' 10 mm fillet welds).
- Butt welds formed by a single run from each side.
- Square edge butt welds using the 'punch-through' technique with the 121 to 125 processes.

(The first two situations are covered in MPS clause 7.507, Ref 18.)

For the above situations there is enough dilution of the weather resistant steel alloying elements into the weld pool to give the corrosion resistance.

EN 1090-2 states that for multi-run fillet and butt welds, the main body of the weld can be made using C-Mn electrodes, capped off with matching electrodes. It is important that any exposed edges should also be capped with matching electrodes.

Multi-run butt welds using the semi automatic sub arc process and weather resistant steel electrodes give satisfactory results. Such welds are usually used for pre-assembly butts in webs and flanges, and are therefore unrestrained. Such butted plates are often subsequently cut into their final shape after welding and it is therefore useful to have the full weather-resistant properties throughout the thickness of the weld.

**Bolted connections**

- Use preloaded bolts, even for non-structural connections, to ensure close contact and avoid crevice corrosion.
- Specify bolts with similar weathering properties, i.e. with chemical compositions complying with ASTM A325, Type 3, Grade A, or equivalent. Never use ordinary plated bolts, as protection would be sacrificed.
- The slip factor may be taken as that for ordinary structural steel.
- Adjacent to an edge, use a maximum bolt spacing of 14 times the thickness of the thinner plate or 175 mm (whichever is less); use a maximum edge distance of 8 times the thickness of the thinner plate or 125 mm. (Alternatively, protect the joint.)
- Do not specify load-indicating washers, as this leaves crevices (in any case, they are not available in weather resistant steel).

Where bolt spacings are wider than recommended above, or where there are features thought to increase the risk of water intake,

# Guidance Note

## No. 1.07

---

the joints should be protected by suitable sealants.

### Surface finish

- For uniform appearance, specify the removal of mill scale and contaminants and give an all-over post fabrication blast clean with chilled iron grit or non-metallic grit to a minimum standard of Sa2
- The use of wax base markers (during fabrication) must be prohibited, because trace amounts will remain, even after blasting, and these will become very apparent after weathering
- Local painting of vulnerable areas may be acceptable: select a colour match corresponding to that which will exist after about two years of weathering (i.e. dark brown).
- Do not use enclosures for new weathering steel bridges. They are designed to inhibit corrosion and are therefore not compatible or economic for use with weather resistant steels. However, they may be appropriate as a remedial measure in the unlikely event that the weathering steel does not perform satisfactorily.

The external faces of outer girders may sometimes be painted for reasons of appearance. However, this will reduce the cost and maintenance benefits of using weather resistant steel.

The outer surfaces of box girders may also be painted for aesthetic reasons, or where the external environment is not suitable for unpainted weathering steel. The use of weathering steel in such cases yields health and safety benefits, because maintenance work inside the box girder is minimised.

### Construction

Care is needed on site with both storage and handling of the steelwork such that the developing rust 'patina' is not damaged. Although the 'patina' will re-form, it will appear non-uniform until that time. In addition, grout runs from deck concrete operations should be avoided, as they will adversely affect the steelwork, which may necessitate a final blast cleaning after site erection. During construction, piers and

abutments should be protected from rust staining, as the 'patina' forms, by wrapping them in protective sheeting until the final construction inspection is made.

### Inspection and monitoring

- 'As-built' drawings should show vulnerable locations and record initial steel thicknesses at specific and re-locatable (well marked) positions.
- Visual inspection of critical areas should be carried out at intervals not exceeding two years; thickness measurements should be taken at six-yearly intervals. If, after at least 18 years, the predicted loss of section exceeds the original loss allowances over the design life (120 years according to the NA to BS EN 1993-2, Ref 21), then a protective system may have to be provided at an appropriate time.
- Inspectors assessing surface condition should be able to distinguish between a tightly adhering rust coating (which is performing satisfactorily) and one that has granular or flaky appearance (which are danger signs). The surface may be 'dusty' in the early stages; this is acceptable.

### Routine maintenance

Surfaces contaminated with dirt or debris should be periodically cleaned by low-pressure water washing where practical, taking care not to disrupt the protective 'patina'. Overhanging vegetation causing continuous dampness should be removed, and drainage systems should be regularly cleared. Any leaks should be traced to their source, and the drainage systems or joints responsible should be repaired or replaced. If there is evidence of 'pack-out' of crevices at bolted joints, then the edges of the joint should be sealed with an appropriate sealant.

### Remedial measures

If in practice it is found that chlorides are adversely affecting the stability of the rust 'patina', and causing corrosion of the substrate, then annual low-pressure water washing at the end of the de-icing period can alleviate the problem.

Other remedial measures include blast cleaning to remove the rust 'patina', and

repainting either in part or of the whole bridge, and enclosure of the steelwork in a proprietary system.

#### **Removal of graffiti**

The removal of chalk graffiti should be achievable by using low pressure water jetting, taking care not to disrupt the protective rust 'patina'. Such an operation is unlikely to affect the durability of the structure.

The removal of spray paint will probably require higher pressures that are more likely to remove the protective rust 'patina', particularly if abrasives have to be used. Unfortunately, it is difficult to predict the degree of damage to the rust 'patina' (and hence the effect on durability) as that depends on how hard it proves to remove the paint. This in turn depends on a number of factors including the type of spray paint, the age of the graffiti, and the original condition of the rust 'patina'. However, should removal of the rust 'patina' be required to remove the graffiti, then the weathering process will have to start again. Clearly it is not advisable to do this too many times, as it will adversely affect the durability of the structure.

In terms of developing a maintenance strategy, a fall back position (if repeated graffiti removal does adversely affect the durability) would be to locally paint the affected area (i.e. outside face of the outer girder) in a colour to match that of the mature steel.

#### **Availability**

As weathering steel is not produced in the same quantities as conventional structural steels, designers should take into account the availability of weather resistant steel plates, sections and bolts at both the concept and detail design stages. The following comments relate to availability from Corus.

#### *Plates*

Plates may be obtained direct from the mill, where a minimum quantity of 5 tonnes per width and thickness applies, or from ASD Glen Metals (the UK main steel stockist for weathering grades). Details of available plate lengths, widths, and thicknesses are given in

Corus' brochure on "Weathering Steel Bridges" (Ref. 11)

#### *Sections*

Corus no longer produce rolled sections in weather resistant steel grades. I-section girders for ladder deck cross girders and for main girders of short span multi-girder bridges can be economically fabricated from plate. Angle and channel sections for bracing members can also be fabricated from plate and since the quantity of these members is likely to be small in most cases, there is only a modest cost penalty. Nevertheless, it may be more economic to choose arrangements that use minimal amounts of bracing – avoiding the use of knee bracing in ladder deck construction, for example, or using a stiff I-section between a pair of girders, rather than a triangulated arrangement of angles. Steelwork contractors can advise on the practicability of fabricating bracing members and the alternative options.

#### *Hollow Sections*

Hollow sections to BS 7668 are no longer available from Corus. If the use of such sections is desired, then an alternative supply route should be established at a very early stage in the design process.

#### *Bolting assemblies for preloading*

The majority of weathering grade preloaded bolts (HSFG bolts) used in bridge construction are currently imported. Many come from North America (in imperial sizes and to US specifications), but often they can be sourced from elsewhere in metric sizes.

Hence, the recommended approach to this issue is to standardise the connection design on the use of M24 bolts, but to choose bolt spacings to suit 1" bolts, as this will maximise the procurement options available to steelwork contractors, i.e. they can substitute 1" bolts for M24s without adversely affecting the layout or design of the connection.

Alternatively, if it is known that the steelwork contractor will be importing weathering grade bolting assemblies from North America, it is clearly more economic to use the



# Guidance Note

## No. 1.07

---

additional resistance due to the slightly larger 1" bolts in the connection design.

It is advisable to talk to fabricators about the use of such bolts at an early stage in the design process, and be flexible to accommodate alternative proposals.

### **Additional comment**

#### *'Tunnel-like' conditions*

'Tunnel-like' conditions are produced by a combination of a narrow depressed road with minimum shoulders between vertical retaining walls, and a wide bridge with minimum headroom and full height abutments. Such situations may be encountered at urban / suburban grade separations. The extreme geometry prevents roadway spray from being dissipated by air currents, and it can lead to excessive salt deposits on the bridge girders.

#### *Risk of bimetallic corrosion at bearings*

For bi-metallic corrosion to occur two dissimilar metals need to be in direct electrical contact with each other and an electrolyte. Aspects that influence bimetallic corrosion are the nature and conductivity of the electrolyte, the relative surface areas of the anodic and cathodic metals, and the respective positions in the galvanic series.

For the majority of weathering steel bridges, the only area to consider in terms of this effect is the connection between the steel girders and the structural bearings.

For the case of weathering steel girders on ordinary structural steel bearings, there is no significant difference between the reactivity of the two metals and as the ordinary structural steel is painted, there is no contact with an electrolyte. Hence bimetallic corrosion is unlikely to occur.

For the case of weathering steel girders on stainless steel bearings, there is a significant difference between the reactivity of the two metals and as both metals are uncoated, there is potential for contact with an electrolyte. However, the surface area of the weathering steel (that would corrode preferentially to the stainless steel) is vast in comparison to the small stainless steel bearing. In addition, the bearings are generally

sheltered, so electrolyte is rarely present. Hence, the level of bimetallic corrosion is unlikely to be significant.

### **Further reading and references**

#### *Research papers:*

1. P ALBRECHT and A H NAEEMI, Performance of weathering steel in bridges, NCHRP Report 272, Transportation Research Board, Washington, 1984
2. M MCKENZIE, The Corrosion of Weathering Steel Under Real and Simulated Bridge Decks, Transport and Road Research Laboratory, Crowthorne, 1990
3. J W FISHER, Fatigue Resistance of Weathering Steel Components, Lehigh University, 1989
4. P ALBRECHT and M SIDANI, Fatigue Strength of Weathering Steel for Bridges, University of Maryland, 1987
5. K YAMADA and Y KIKUCHU, Fatigue Tests of Welded Weathered Joints, Journal of Structural Engineering, Vol 110, No. 9, 1984

#### *Guidance to users:*

6. P ALBRECHT, S K COBURN, F M WAT-TAR, G L TINKLENBERG and W P GALLAGHER, Guidelines for the use of Weathering Steel in Bridges, NCHRP Report 314, Transportation Research Board, Washington, 1989
7. Weathering Steel – Connecting with the environment. Corus Construction and Industrial, 2004.
8. WILLIAM L MATHAY, Uncoated Weathering Steel Bridges, AISC Marketing Inc, Pittsburgh PA, 1993
9. F FISCHER and U ROXLAU, Projekt 191, Anwendung wetterfester Baustähle im Brückenbau, University of Dortmund, 1992
10. The Use of Weathering Steel in Bridges, ECCS Advisory Committee 3 Steel Bridges, No. 81 (2001).
11. Weathering Steel Bridges, Corus Construction and Industrial, 2005.

#### *Descriptions and performance of existing bridges*

12. M FISCHER and C SCHULTE, Wetterfester Stahl im Brückenbau, University of Dortmund, 1993

13.D HALDEN, Design and performance of weathering steel bridges on Scottish trunk roads, Proc Inst Civ Engrs, Part 1, London, April 1991

*Specifications, standards and codes of practice:*

14. EN 10025-5:2004 Hot rolled products of structural steels. Part 5 Technical delivery conditions for structural steels with improved atmospheric corrosion resistance.
15. BS 7668: 2004, Specification for weldable structural steels. Hot finished structural hollow sections in weather resistant steels.
16. BD 7/01, Weathering steel for highway structures, 2001, The Stationery Office.
17. EN 1090-2: 2008, Execution of steel structures and aluminium structures - Part 2: Technical requirements for steel structures.
18. Steel Bridge Group: Model project specification for the execution of steelwork in bridge structures (P382), SCI, 2009.
19. DAST Richtlinie 007, Deutscher Ausschuß für Stahlbau, Köln, 1993.
20. ISO 9223: 1992, Corrosion of metals and alloys – Corrosivity of atmospheres – Classification, International Standards Organisation.
21. EN 1993, Eurocode 3, Design of steel structures:  
EN 1993-1-8:2005, Design of joints  
EN 1993-1-9:2005, Fatigue  
EN 1993-2:2006, Steel bridges  
*Plus the UK National Annexes:*  
NA to BS EN 1993-1-8:2005, BSI, 2008  
NA to BS EN 1993-1-9:2005, BSI, 2008  
NA to BS EN 1993-2: 2006, BSI, 2008



## Box girder bridges

No. 1.08

**Scope**

This Guidance Note gives an overview of the main design issues for steel box girders in short and medium span bridge schemes. SCI-publication P140 (Ref 1) gives a more extensive treatment of steel box girder design.

Comments relate principally to the use of box girders as the main girders, acting compositely with a deck slab, but many of the considerations are also applicable where box sections are used as arch members.

Advice on the use of steel box girders in long span road bridge schemes, particularly those with orthotropic steel decks, is not covered by this Guidance Note.

**Current use of steel box girders***Road bridges*

Nowadays, in short and medium span road bridge construction, steel box girders acting compositely with a deck slab are usually only found in schemes where a high emphasis on aesthetics justifies their increased fabrication costs.

Tied arch bridge systems have recently been used effectively and economically for the upper end of the medium span range and box girders are often chosen for the arch members of such bridges.

*Footbridges*

Box girders are used for footbridges curved in plan, bridges with longer spans and cable-stayed bridges with a single plane of stays. All-steel construction is typically used, for lightness.

A single box girder as the main longitudinal spine of the bridge is an excellent solution for such situations. With deck cantilevers, a single box can carry the full width of deck.

*Railway bridges*

Network Rail continues to make use of the 'Western Region' standard box girder bridge system in many situations where construction depth is very tightly constrained. Indeed, the standard designs have recently been updated to conform to design to the Eurocodes.

**Why choose steel box girders?**

The selection, or otherwise, of a steel box girder always needs a consideration of the relative advantages and disadvantages of box girder elements compared to the more traditional I girder elements.

*Advantages, compared to I girders*

- High torsional stiffness and strength, giving greater suitability for horizontally curved bridges, greater aerodynamic stability and reduced susceptibility to lateral buckling of flanges (in lateral-torsional or distortional buckling modes)
- Reduced need for support points
- Improved durability and reduced maintenance of protective coatings (less exposed surface, fewer edges, avoidance of exposed horizontal surfaces, no exposed bracing and stiffeners).
- The clean lines of a closed box girder are also often considered give a better appearance, particularly for footbridges where the visual impact is considered to be important.

*Disadvantages*

- Greater fabrication cost on account of the reduced scope for automated fabrication and greater difficulty of handling and rotating during fabrication and coating.
- Greater design input.
- Risks associated with working in enclosed spaces.

**Design aspects that require particular consideration**

The following aspects are reviewed below:

- Complexity of fabrication
- Internal access
- Stability during construction
- Longitudinal stiffening of plate panels
- Transverse stiffeners and beams
- Control of distortion
- Web/flange welds
- Internal corrosion protection

*Complexity of fabrication*

Once the decision has been made to opt for a steel box girder, it is strongly recommended that a fabricator is consulted as early on in the

# Guidance Note

## No. 1.08

---

design process as possible. Boxes normally need a greater fabrication input, and so the success of a scheme can often depend on whether the design allows efficient fabrication.

It should also be appreciated that the design of a box girder is invariably more complex than that of an I-girder. A box girder needs greater consideration of local buckling, torsion and distortion effects – phenomena not common to I-girder design. Designers also need to establish an appropriate strategy for both the longitudinal and transverse elements of the box.

### *Internal access*

Box girders deep enough to allow internal access will need to provide an access route through the box to enable routine internal inspection. Internal access is also needed by the fabricator to ensure that operatives working inside a closed box can be quickly removed from the box in the event of an emergency.

Previous designs have demonstrated that a minimum internal access hole provision of 600 mm x 600 mm is usually adequate for the needs of both fabricator and inspection authority. However, on account of continuing amendments to safety legislation, it is recommended that internal access provisions are always reviewed and agreed between all parties early in the design stage.

### *Stability during construction*

Closed box girders are inherently very stable torsionally and checks during construction will usually be limited to checking the cross section resistance; lateral torsional buckling is unlikely to reduce the strength unless the box girders have an unusually high height/width aspect ratio.

Open top box girders can, however, be susceptible to torsional buckling during construction before the deck slab has hardened. This problem is identified in AD 331 (Ref 2). Where stability in the temporary condition is a problem, plan bracing will be required to the open top box

### *Longitudinal stiffening of plate panels*

The slender steel plates forming the webs of box girders are often class 4 in bending and

the bottom flanges are usually Class 4 in compression. Local buckling (and thus a reduced effective cross section) may be avoided by increasing the out-of-plane stiffness of the plate. This is achieved either by providing longitudinal stiffeners or by using thicker plates

Longitudinal stiffeners typically take the form of longitudinal flats, bulb flats, Tees or trough sections welded to the inner surface of the plate. Extensive use of longitudinal stiffeners typically enables the thickness of the plates forming the walls of the box to be minimized. Taken to the extreme, this strategy will result in a minimum weight box with high fabrication costs.



**Figure 1** *Internal view of a steel box girder showing use of longitudinal stiffeners*



**Figure 2** *Internal view of a steel box girder where longitudinal stiffeners were avoided by the use of thicker plates*

As an alternative, the number of longitudinal stiffeners can be minimized by providing thicker plates for the sides of the box. This strategy will result in heavier boxes but with minimum fabrication costs. The increased dead weight, usually not a problem over

short spans, can become an issue as spans become longer. When considering the use of thicker plates, the reduced box fabrication costs need to be offset against the resulting increase in temporary works, transportation and substructure costs.

Current box girder designs in the UK have commonly adopted a strategy of minimising the number of longitudinal stiffeners through the use of thicker side wall plates, as current fabrication techniques still typically result in heavier, lightly stiffened boxes being more economical than heavily stiffened, lighter boxes. As this could change in the future with developments in stiffened plate fabrication technology and fluctuations in global steel prices, the preferred longitudinal stiffening strategy should always be discussed with a fabricator early in the design process. It is also noted that the design rules in BS EN 1993-1-5 typically lead to greater resistance from stiffened structures than the rules in BS 5400-3 and this will also encourage a return to thinner stiffened plates.

#### *Transverse stiffeners and beams*

Internal transverse stiffeners or beams will be needed for the following reasons:

##### *a) Enhancing the shear strength of webs*

The webs of a box are typically very slender and require transverse stiffeners to provide the design shear resistance.

##### *b) Restraining longitudinal stiffeners*

Buckling of longitudinal stiffeners in compression needs to be restrained by appropriate transverse elements of adequate stiffness.

##### *c) Providing paths for local loads*

Concentrated local loads from components such as cable hangers and support bearings need to be distributed safely into the box sides via a load path provided by transverse beams.

#### *Control of distortion*

Where vertical loads are applied eccentrically (normally at top flange level), the torsional component of the loading is girder not a 'pure' (St Venant) torque and the cross section is subject to forces that tend to distort to shape of the cross section. These distortional forces induce both longitudinal stresses from in-plane bending of the box

walls (known as distortional warping stresses) and transverse bending stresses in the box walls (known as distortional transverse bending stresses). Both need careful consideration during design. Box distortion is controlled with the use of internal diaphragms or cross frames that limit the extent of the distortion. These internal diaphragms or frames can take many forms :

- Full depth unstiffened diaphragms
- Full depth stiffened diaphragms,
- Triangulated cross frames (see 0)
- Ring frames (see Figure 1)

The selection of an appropriate form of diaphragm or frame and the spacing will need to be considered in conjunction with any requirements for transverse stiffeners or beams; the diaphragms or frames will also provide transverse restraint to the flange and web panels and their stiffeners.

Distortional stiffening is also needed by the fabricator to control the shape of the box during construction. The ideal arrangement is where the chosen distortional stiffening design can meet the requirements of both service loads and fabrication.

Many box girder schemes meet all of these requirements via a transverse stiffening strategy of regularly spaced, plated diaphragms or cross frames. The ideal transverse stiffening strategy will meet all of the above demands in conjunction with being economic to fabricate and thus should be derived through close collaboration between designer and fabricator early on in the design phase.

#### *Web/flange welds*

The web/flange welds are subject to longitudinal shear and to transverse bending associated with distortional effects. Tee joints with double fillet welds are usually sufficient but over-design of the welds can result in an unnecessary increase in fabrication cost. Full penetration butt welds should only be specified where truly necessary. Designers are strongly recommended to ensure that their box corner weld details can be fabricated efficiently.

#### *Internal Corrosion Protection*

The inside of a box will usually require corrosion protection. Traditionally, as illustrated in

# Guidance Note

## No. 1.08

---

Figure 1, the insides of steel boxes were protected by the application of an appropriate light-duty paint system designed to withstand the mild corrosion environment present inside the box.

Painting inside a steel box girder has many disadvantages:-

- Economic – The box girder element needs to be painted both inside and out
- Health and Safety - The paint needs to be applied in a confined space.
- Application - The degree of stiffening inside a box makes the application of a uniform coating difficult.

To avoid these disadvantages, modern steel boxes such as the box illustrated in Figure 2, are now predominately fabricated from weathering steel, with a small allowance for corrosion of the internal surface. This avoids the need to paint inside the box, even if paint is still required on the outside of the box for aesthetic or other reasons.

Guidance on corrosion allowances, for weathering steel and structural steel, is given in clause NA.2.14 of the National Annex to BS EN 1993-2 (Ref 3).

Adequate drainage should also be provided to allow any water ingress to drain out of the box void. General guidance on drainage is also given in NA.2.14.

For further details of designing with weathering steel, readers are also referred to a Corus publication (Ref 4).

Sealing boxes that are large enough to access is not recommended. It is very difficult to guarantee an airtight seal. If sealing is attempted, a pressure test should be undertaken to demonstrate the adequacy of sealing and the box must be designed for the pressure difference between internal and external environments.

### References

1. Design guide for composite box girder bridges (P140), SCI, 2004

2. Advisory Desk Note: AD331 Open top box girders for bridges, SCI, 2009 (available on [www.steelbiz.org](http://www.steelbiz.org))
3. NA to BS EN 1993-2:2006, UK National Annex to Eurocode 3: Design of steel structures. Steel bridges
4. Steel Bridges - Material matters, weathering steel (Section 8.4, Box Girders), Corus 2009.

## Comparison of bolted and welded splices

No. 1.09

### Scope

For all except the shortest bridges (under 27 m overall length) site splices of the main girders are likely to be necessary, due to limitations of fabrication, transport or erection. Whether such splices should be welded or bolted is a frequent subject of discussion; each method of splicing

has its advantages and disadvantages, not all of which are always recognised at the design stage. The purpose of this Note is to present a summary comparison of the two types, to aid the selection process. The comparison is made in tabular format, for ease of use.

### BOLTED SPLICE

### WELDED SPLICE

#### Appearance

Bridge designers and clients can be oversensitive to the visual impact of bolted splices.

Bolted splices are usually relatively small in outline (e.g. M24 bolts with a 15-20 mm thick bottom flange cover plates), will be painted the same colour as the remainder of the deck and are usually in the shadow of the cantilevers.

The use of bolted splices may be in keeping with the industrial nature of the area if there are, for example, riveted structures nearby.

Bolted splices may occasionally be considered unacceptable in areas where pedestrians can observe the bridge at close quarters.

The appearance is slightly better when the heads, rather than the nuts, are on the visible faces of the structure.

Bolted splices are less noticeable when a dark shade of paint is used.

For all columns in the central reserves of roads, beam splices equidistant on either side of each column look better than asymmetric positioning, although sometimes the solution is a single splice

Cleaner line to steelwork. However, the welded beam will not be completely devoid of visible features; the position of the welded splices will still be observable, and deformation of thin stiffened webs (arising from weld distortion) may be visible in certain lighting conditions.

Welds may be ground flush for a landmark structure in a sensitive area (although care must then be used to avoid creating a visibly different surface texture).

#### Structural performance

A bolted joint may be designed for the loads at the splice position, not the full strength of the section.

The splice detail generally does not govern fatigue life.

A full strength joint is achieved with full penetration butt welds.

The splice detail may reduce fatigue life.

- With plated and rolled sections, a class 112 detail can be achieved by using run-on and run-off plates, welding from both sides and grinding flush - see Table 8.3 of EN 1993-1-1. For plates thicker than 25 mm, a reduction applies. Without grinding flush, a class 90 detail is obtained.
- When cope holes are provided (to allow access to make the flange butt welds) the opening creates a class 71 detail in the flange and in-



# Guidance Note

## No. 1.09

<b>BOLTED SPLICE</b>	<b>WELDED SPLICE</b>
<b>Practicality of Construction</b>	
<p>Cover plates and limited number of bolts can be used to support the girder during erection.</p> <p>Easier control over finished shape of the girder can be exercised when templating techniques are used during fabrication and assembly to ensure accuracy in matching adjacent members. On the other hand, normal clearance bolt holes permit significant rotational adjustment and some longitudinal and vertical adjustment.</p> <p>Splices can be completed by the erectors.</p> <p>Splice is not weather-dependent for bolting up. Tent around the splice not usually required. Joints will dry out naturally in warm weather, especially when protected by a deck.</p> <p>All welding, blast-cleaning, aluminium metal spraying and aluminium epoxy sealer application to the splice components is carried out in the shop, where application conditions are easier to control.</p>	<p>Introduces a stress concentration factor of 2.4 in the web at the top of the hole (so it is best to avoid a butt weld in the web at the cope hole). It is best to butt weld an infill piece into the cope hole.</p> <p>Temporary supports or landing beams required to support the girder until welding is complete. Temporary cleats also required to align joint (these have to be welded and removed later).</p> <p>Less control over finished shape of the girder due to shrinkage and distortions caused by welding. On the other hand, longitudinal tolerances can be accommodated by varying weld gaps (but welding parameters may then need to be modified).</p> <p>Qualified welders, working to approved procedures, are needed to complete splices, to ensure the required geometry.</p> <p>Splice weather-dependent for welding (including pre-heat), metal spraying and completion of painting. A weatherproof tent around the splice is almost certainly required.</p> <p>Site welding, cleaning, spraying and painting of spliced regions require greater attention and increased supervision, with application conditions being less easy to control (especially significant for blasting).</p>
<b>Economics</b>	
<p>The general rule is that bolted site splices are cheaper.</p> <p>Even for large jobs site bolting may still be more economic than welding because of the considerable reductions in time spent on site and, particularly, the duration of steel erection.</p> <p>All blast cleaning carried out in the shop.</p> <p>All aluminium metal spray application carried out in the shop.</p>	<p>Welded site splices are generally more expensive because of costs of welding plant, procedure trials, protection of joints, NDT, electrode storage, addition/removal of fairing aids (to align parts to be welded) and additional restraints to beams.</p> <p>However, for large jobs (e.g. 500 connections, see Ref 1), welding may be more economical.</p> <p>Blast cleaning around welds carried out on site. (The cost of this additional activity is probably accounted for in Ref 1)</p> <p>The extra expense of site metal spraying is not included in Ref 1, as metal spray is not always required.</p>

BOLTED SPLICE	WELDED SPLICE
<p>Lower supervisory costs.</p> <p>Less traffic disruption during erection of spans particularly over existing motorways.</p> <p>Less risk of delay to contract (see comments on programming).</p>	<p>Greater supervisory costs due to greater level of checking and requirement for specialist knowledge.</p> <p>Greater traffic disruption due to longer time required for diversion or protection while spans are erected and welded.</p> <p>Greater risk of delay to contract may be reflected in an increased contract sum.</p>
<b>Programming</b>	
<p>Bolting of splices takes less time than welding and can be programmed with greater certainty. Not all of the bolts need to be installed as a critical path activity.</p>	<p>Welding of splices will normally extend the time required for construction, particularly over existing roads. This is because it extends the critical path activities and because of:</p> <ul style="list-style-type: none"> <li>• need to erect tents around the splices to allow effective preheating and welding under all weather conditions</li> <li>• completion of welding; the multi-run welds required for a thick flange will take time</li> <li>• possible need for infilling of cope holes to achieve the required fatigue life</li> <li>• NDT of welds The minimum hold period before testing given in EN 1090-2 Table 23 (typically 40 hours for butt welds in S355 steel) is warranted, to safeguard against hydrogen cracking. This delay would then apply in addition to any repairs.</li> <li>• additional corrosion protection activities of blast cleaning, aluminium metal spraying and sealant coat application.</li> </ul>
<p>Little risk of remedial work, and probably only minor repainting, which could be done quickly or during closure for other work.</p>	<p>Greater risk of remedial work being required. Any welding remedial work could cause delay.</p>
<p>Negligible risk of delay to contract completion.</p>	<p>Risk of delay to contract completion if the construction of spans over a motorway (or, worse still, over a railway) is on the critical path.</p>

**General design comments**

Whether bolting or welding a splice, it is good practice to place splices where forces are lowest (i.e. at points of contraflexure), and to enable connections to be completed with zero bending moment (this avoids extra jacking activity).

1. Hayward A and Weare F, *Steel Detailer’s Manual*, Second Edition (revised by Oakhill), Blackwell Science, 2002

*(See also references in GN 2.06).*



## Half through bridges

No. 1.10

**Scope**

This Guidance Note describes the structural action and typical applications of this type of bridge. Aspects requiring particular attention are identified.

**Basic form and structural action**

The basic half-through deck configuration (Figure 1) is characterised by two essential features:

- The deck slab (or steel deck) is located towards the bottom flange or chord of the main (longitudinal) girders.
- No lateral bracing members exist between the main girder top flanges or chords.

Additionally, where the main girders rely on U-frame action for stability, stiff connections must exist between the deck and the main girders.

These features have implications for design and detailing, some of which are described below.

The most important aspect of the half-through configuration from the structural point of view, is that stability of the compression flange or chord in sagging moment regions is achieved by virtue of the flexural stiffness of 'U-frames' formed by the webs (usually having vertical stiffening which aligns with the cross girders) and the deck slab and/or cross girder. The ends of the girders will often be restrained by stiffer end U-frames or by a suitable arrangement of trimmer beam and bearing stiffeners. Line rocker bearings may also be used to provide end restraint.

The stiffer the U-frames, the greater the degree of restraint afforded to the top flange and hence the greater capacity of the main girders. Inevitably, however, a compromise has to be reached between maximising the bending capacity of the main girders and providing an optimum U-frame configuration related to the selected cross girder spacing and web stiffening requirements.

The mathematical model underlying design guidance for half-through girder decks (i.e. that in BS 5400-3 (Ref 1) and in EN 1993-2 (Ref 4)) is the beam on elastic foundation (BEF) model. The model comprises a strut (the isolated compression flange) laterally restrained

by springs. The effective length of flange or chord calculated from this model is used to determine flange slenderness and hence the limiting stress.

It should be realised that overall stability relies upon the deck being rigid in plan for the full span length, unless some other bracing restraint system is provided.

The inherently high torsional rigidity of box girders means that the requirement for restraint against buckling is less than for a plate girder or truss; however, the degree to which this is true is dependent on the box width to span ratio. In most cases, box girders require no intermediate restraint, but they must then be restrained against overall instability (twisting about the longitudinal axis) at the supports (by the use of twin bearings or wide line rocker or roller bearings).

The U-frame stiffness (expressed as the parameter  $C_d$  in EN 1993-2 and the value  $1/\delta$  in BS 5400-3) is determined by the aggregate stiffness of the three component parts of the frame, viz:

- the deck and/or transverse beams forming the invert of the U-frame.
- the webs of the main girders, plus associated stiffeners, that form the vertical legs of the U-frame.
- the joint between the deck and the main girders.

It should be noted that Table D.3. in EN 1993-2 gives expressions for  $C_d$  that do not include a term for joint stiffness/flexibility but the flexibility of the joints should be allowed for. (The point is made, in principle, in EN 1993-1-1, 5.1.2, and EN 1993-1-8, 5.1.1, although the rules are expressed in terms more familiar to building designers.) The joint flexibility can be allowed for by adding the term  $h^2 E I_w / S_j$  in the denominator of the expression in row 1a of Table D.3, where  $S_j$  is the stiffness of the joint. (In the absence of values of  $S_j$  appropriate to the type of joints used in bridge U-frames, values of  $1/f$  may be used as guidance, where  $f$  is the flexibility parameter given in BS 5400-3.)

Individual U-frames must possess sufficient stiffness and strength if they are to restrain the

# Guidance Note

## No. 1.10

---

compression flanges in the desired manner. Although it is stiffness rather than strength which theoretically determines the effectiveness or otherwise of the lateral restraint, the requirement for adequate strength cannot be ignored. Lateral forces on the top flange or chord from vehicle impact may need to be allowed for. Codified design guidance therefore provides both minimum stiffness and strength criteria for U-frames.

Where a continuous half-through deck is used in a multiple span application, stress in the top flange or chord becomes tensile in hogging moment regions and, consequently, buckling instability is not in question. In these regions the compression (i.e. lower) flange is laterally restrained by the deck.

A general point is worthy of note here: a point of contraflexure in the bending moment diagram is not equivalent to a lateral restraint. A point of contraflexure has no lateral restraint framing in to it, and it can therefore displace laterally; consequently it cannot be relied upon to form a 'node' in the plan buckling configuration.

Second order 3-dimensional analysis may be appropriate to evaluate action effects and considerations of buckling stability of half through bridges, especially for heavily skewed spans. The successful completion of such an analysis will need to ensure a rigorous treatment of the effects of worst case geometric imperfections, joint / material non-linearities and residual stresses. Correlation of the analysis output against physical testing and research results is recommended whenever possible.

### **Advantages of half through construction**

The principal advantage afforded by the half-through deck is minimum effective construction depth; see Figure 1. (This is also true for a fully through deck, where, instead of U-frame action, lateral bracing is provided above the traffic.) Consequently, where deck soffit levels are constrained to be as high as possible and carriageway or rail levels on the structure as low as possible, a through or half-through deck will frequently be the preferred, if not the only feasible, solution.

Minimum effective construction depth sometimes has the added advantage of minimising the volume of fill material required for approach

embankments, or where the depth of a cutting must be minimised, for example when a new roadway is to be constructed beneath an existing railway.. This may or may not be significant for a particular scheme.

### **Typical applications of half through decks**

Perhaps the two most common applications of half through construction are pedestrian bridges (Figure 2) and railway bridges (Figure 3). For railway bridges it is usual practice for intermediate vertical stiffeners to be external to simplify the form of joints to cross girders. Guidance on railway bridge design is given in Reference 3; this illustrates various forms of half through construction and discusses the considerations for their design.

Half through construction has not been used to the same extent for highway underbridges. There are perhaps a few reasons for this:

- Minimum effective construction depth is rarely the overriding design consideration.
- Required deck widths are frequently large enough to render the U-frames very flexible. In turn, this means low levels of restraint to the compression flange and inefficient use of material in the main girders.
- The increased risk of vehicle collisions with the main girders (vehicles carried by the half through bridge). In some cases it may be necessary to provide 'P6' parapets to minimise the risk of collision damage to the main girders.
- The aesthetics of a plate girder half through deck may be less acceptable especially if main girders are stiffened on the external face.

Nevertheless, half through highway bridges based on plate girders or trusses are perfectly possible (Figures 4 & 5), provided that decks are not too wide.

### **Erection Considerations**

Although compression flange stability is provided by U-frame action in the completed structure, the erection scheme must consider buckling and overall stability before the U-frames are formed and plan rigidity has been achieved.

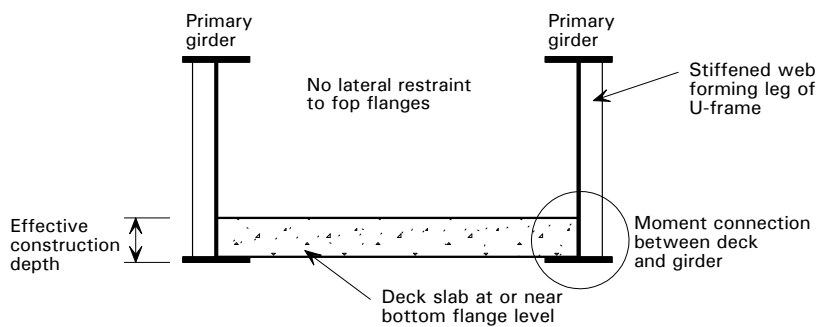

**Figure 1** Basic configuration of half-through bridge deck

**Skew spans**

The designer should note that half through construction for heavily skewed decks requires particular consideration of the U-frame stiffness between the obtuse and acute corners of the bridge, the form and orientation of the bearings, and interaction with trimmer girders, particularly in relation to interpretation of codified design guidance. For example, L frames rather than U frames provide compression flange restraint at the ends of the deck, but the codes do not explicitly cater for skew.

**References and further reading**

1. BS 5400-3:2000, Code of Practice for design of steel bridges, BSI, 2001.
2. BA 53/94, Bracing systems and the use of U-frames in steel highway bridges, HMSO, 1995.
3. Design guide for steel railway bridges (P318), The Steel Construction Institute, 2004

4. EN 1993-2:2006, Eurocode 3: Design of steel structures – Part 2: Steel bridges.
5. EN 1993-1-1:2005, Eurocode 3: Design of steel structures – Part 1-1: General rules and rules for buildings.
6. EN 1993-1-8:2005, Eurocode 3: Design of steel structures – Part 1-8: Design of joints.

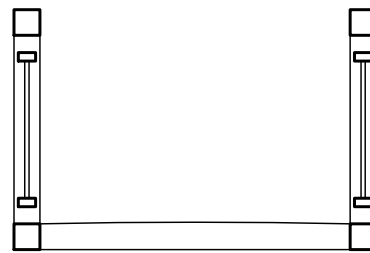
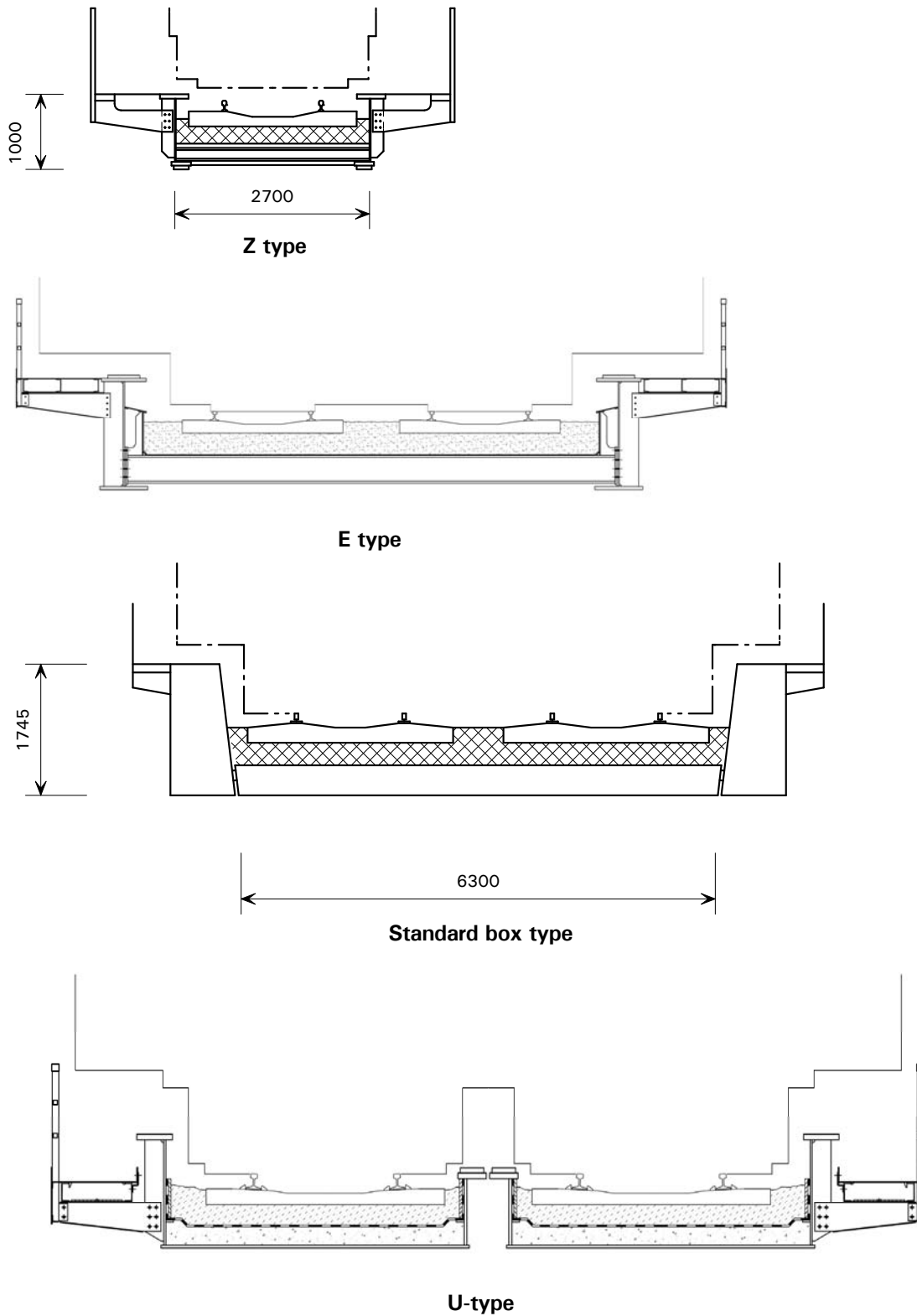

**Figure 2** Typical half-through pedestrian bridge (truss and viendeel girder construction)

# Guidance Note

## No. 1.10

---



**Figure 3** *Standard half-through railway bridges*

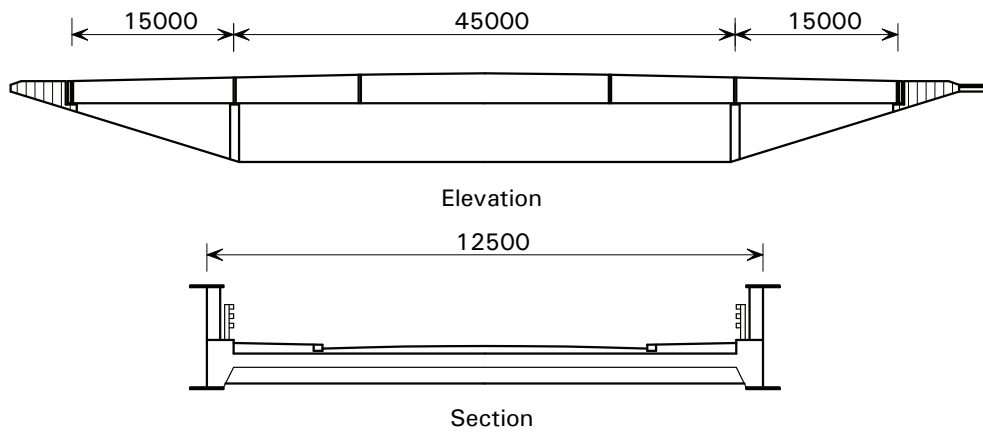

**Figure 4** Typical multi-span half through plate girder highway bridge

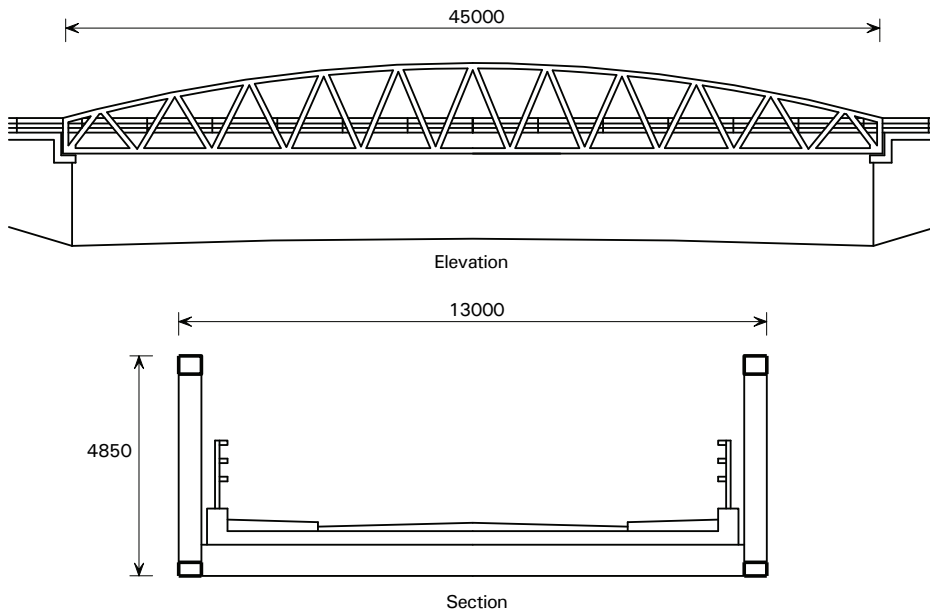

**Figure 5** Typical half-through truss highway bridge





#### Scope

This Guidance Note covers the make-up of bridge girders. Whilst the Note is written principally with I-section steel bridge girders in mind, much of the information is equally applicable to steel box girders for short and medium spans.

The selection of the configuration of the bridge and its structural arrangement is part of conceptual design and is outside the scope of this Note. Brief mention of typical arrangements is made below, and some guidance on highway bridge arrangements is given in Reference 1.

#### Bridge arrangement

The designer will determine the span lengths of the bridge from consideration of the physical dimensions of the obstacle to be crossed, the required clearance envelopes, the available locations for the abutments and intermediate supports (if more than one span) and aesthetics.

For bridges of more than one span, variable depth girders may be chosen, if appropriate.

The number of main girders in the deck cross section is determined principally by the required width of the deck and the economics of the steelwork. In composite highway bridge construction the two arrangements that are most commonly used are:

- multiple longitudinal main girders with the deck slab spanning transversely
- a 'ladder deck' comprising two longitudinal main girders with the deck slab spanning longitudinally between cross beams.

For railway bridges, the requirement to minimise construction depth below track level may necessitate the use of half-through construction, in which the deck is supported by cross girders spanning between a pair of main girders. Typical examples are given in GN 1.10. When there is no requirement to minimise construction depth, the deck (of steel or composite construction) may be supported on longitudinal main girders. In this case, the main girders are normally located directly under each rail, to minimise transverse bending effects.

#### Main girder make-up

Once the structural configuration of the bridge and the number of girders in the deck cross

section has been selected, the designer will determine the required sizes of top and bottom flanges at the critical sections, namely those at the positions of maximum moment. Similarly, the maximum shear forces are critical for determining the required thickness of the web at the supports.

In order to make the most economical use of material, flange sizes and the web thickness should be reduced away from the critical sections (except for short spans, under about 25 m). The make-up of the main girder is determined by consideration of the available sizes of steel plate of the required width and thickness, the lengths of the spans and the maximum length/weight that can be transported to site and erected.

In the UK, the Corus plate products catalogue provides information on the range of sizes that is available for plates. Generally, plates of the thickness most commonly used in bridge girders are available in lengths up to 18.3 m, although on some occasions longer lengths may be available by arrangement. Hence, the flanges and webs of girders will normally (except for short single spans) be fabricated from a number of plates arranged end to end. Long girders must be subdivided into a number of erection pieces for handling and transport. Girder lengths up to 30 m can be transported by road without a movement order (see GN 7.06), and fabricators often transport longer lengths. This is also the case for individual erection pieces.

The plates making up a girder or erection piece may either be joined in the fabrication shop (a shop splice), which usually means a full penetration transverse butt weld, or at site. A site splice (sometimes known as a field splice) can be either a bolted connection or a transverse butt weld. (Note that some site splices are made at ground level, to join several components before erection.)

Transverse butt welds are expensive so it may be more economical to continue a thick flange plate over a longer length. The optimum girder make-up will usually result from:

- minimising the number of transverse butt welds made in the shop (particularly in the flanges)

# Guidance Note

## No. 2.01

- maximising the length transported to site, thereby minimising the number of connections made at site
- positioning site splices to suit the method of erection.

For multiple span bridges, erection by crane typically involves pieces that cantilever to the point of contraflexure in the next span, with a bolted site splice at the connection (see Figure 1). For long spans one or more site splices may be made on the ground before the girder is lifted and placed onto the substructure. The make-up of the girder and the locations of the site splices need to be considered together.

### Flange and web sizes

Variations of the flange size affect the cross section geometry, with implications for the fabricator and the erector.

#### Flange width

Where possible, the designer should choose a combination of width and thickness that provides a balance between a wide, thin plate that would be likely to distort or ripple and a narrow thick plate that might be difficult to weld (for various reasons).

For design to EN 1993-2, (Ref 2) the limits on outstand flanges in compression are in Table 5.2 of EN 1993-1-1 (Ref 3). For a Class 2 cross-section, which can develop the plastic moment resistance, the outstand  $c$  is limited to  $10tE$  ( $= 8.1t$  for  $f_y=355$ ). For a Class 3 section, which reaches the elastic yield strength but will not develop plastic resistance, the outstand  $c$  is limited to  $14tE$  ( $= 11.3t$  for  $f_y=355$ ). Tension flange outstands are not limited by EN 1993 but designers may wish to continue to observe the old limit of  $16t$  from BS 5400 Part 3 1982 (Ref 4). (If a wide flange were to go into compression during handling or erection it would buckle at a very low stress.) Commonly used

proportions for the overall width of flange are therefore in the range of  $12t$  to  $32t$ .

Note that compression flanges need to be kept as wide as possible to increase their resistance to lateral torsional buckling, particularly the top flanges in midspan regions (for the construction condition). This may preclude the choice of compact proportions for the bare steel beam.

Some rolling mills produce material in the form of 'wide flats' in rounded dimensional sizes. The material standards cover these products.

In composite construction a constant flange width may be chosen for the top flange as this simplifies the geometry of slab soffit and the detailing of the reinforcement. A constant width top flange is also preferable when proprietary permanent formwork is used for the slab. A constant flange width is sometimes chosen for the bottom flange for appearance. A constant width within a girder piece also avoids difficulties with automatic girder welding machines (it is difficult to accommodate a sudden change of flange width). Where flange widths do change, designers usually make the change at a splice position.

In railway bridges, flange plate widths are usually kept constant for fatigue design reasons. The width of the top flange may also be influenced by its use as a walkway across the bridge.

#### Flange thickness

Where the thickness of the flange varies, the designer should keep the overall girder depth constant and vary the web depth (see Figure 2). However, prevention of water traps in weathering steel girders sometimes makes it better to vary the bottom flange thickness downwards (keeping the top surface at the same level).

Steps in the web can easily be made when they

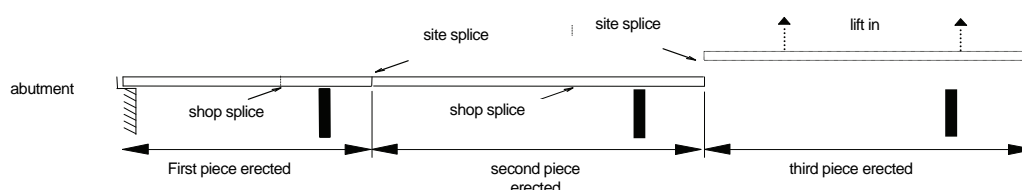
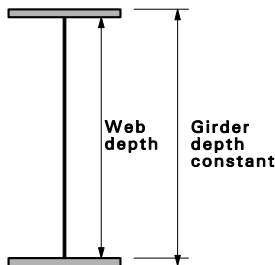

Figure 1 Erection sequence of pieces

are cut from plate. If the web were constant depth, the step in girder depth would be more difficult to accommodate in an automatic girder welding machine.



**Figure 2** *Girder section*

#### *Doubler plates*

Network Rail limits the flange plate thickness in railway bridges to a maximum of 75 mm. Thicker flanges are obtained by welding on doubler plates; the doubler plate thickness is generally slightly less than the primary flange plate (the plate attached to the web). Doubler plates are often curtailed short of the girder ends. See GN 2.02 for comment on detailing doubler plate details.

#### *Web thickness*

Whilst the thickness of web needed in midspan regions is often quite low, a minimum thickness for robustness should be observed. A minimum of 10 mm is commonly adopted in highway and railway bridges (and 8 mm, or possibly even 6 mm, in footbridges). The possible effects of erection conditions on thin webs should also be considered carefully when selecting the make-up (particularly where girders are launched).

#### **Attachments**

The make-up of a girder includes all the pieces that are attached to the girder in the fabrication shop. The principal attachments to plate girders are web stiffeners and shear connectors. On large girders there may be longitudinal stiffeners, and in box girders there are also diaphragms and/or ring frames.

#### *Web stiffeners*

The size of any web stiffeners, their locations and their orientation (e.g. whether transverse stiffeners are square to the top flange or truly vertical) should be given on the make-up sheet. See GN 2.04 and GN 2.05 for comment on attachment of stiffeners.

#### *Shear connectors*

In composite construction, the spacing of the shear connectors should be selected to avoid clashing with the transverse reinforcing bars in the bottom mat of the deck slab; the spacing is often varied in groups along the spans. The spacing and number in each group should be given on the drawings. The starting point for measurements should be clear (avoid appearing to locate the first group at the very end of the girder), as should the line of measurement (whether in horizontal plan or along the top of the steelwork, for example).

#### *Site connected attachments*

Details of other attachments, such as bracing, diaphragms, etc. are usually given separately, but the make-up sheet is often used to give references to indicate which attachment will be made where.

#### **Material grade**

Whilst it is usually good practice not to mix grades of material in made-up girders (to avoid risk of using the wrong grade), where there is little risk of confusion, for example for thick flange material, the selection of different grades (e.g. sub-grade K2 rather than J2) is normal.

If material with through thickness properties is required in particular locations, this should be noted. It is better not to make this a general requirement; only those locations that require the enhanced properties should be so specified. See GN 3.02 for guidance on through thickness properties.

#### **Information about make-up**

Make-up information is usually communicated in graphic and tabular form (e.g. typical cross sections plus separate make-up sheets)

Two typical make-up sheets from actual projects are included at the end of this Guidance Note. Each includes many, though not all, of the aspects mentioned above. They should be considered as illustrative only, and not taken as definitive.

Electronic methods of information transfer are increasingly being used. Whilst this carries many benefits, drawings are still of great assistance in illustrating the designer's needs, in review and in approving proposals made by the fabricator.

# Guidance Note

## No. 2.01

---

Dialogue between designer and fabricator is important to make sure that all the necessary allowances (for cutting and weld shrinkage effects, allowance for permanent deformation, etc.) have been made by the appropriate party.

### **Geometrical information**

It is common for geometrical information, particularly relating to the vertical profile, to be included on drawings showing the girder make-up. This information is of particular relevance to the make-up of the web, since it completes the information needed when ordering material and cutting out the webs.

Note that any allowances for permanent deformation need to be associated with the vertical profile. See GN 4.03 for guidance on allowances for permanent deformations.

### **References**

1. Design of composite highway bridges, The SCI, 2009.
2. EN 1993-2:2006 Eurocode 3 – Design of steel structures – Part 2: Steel bridges
3. EN 1993-1-1:2005 Eurocode 3: Design of steel structures – Part 1-1: General rules and rules for buildings
4. BS 5400-3: 1982, Steel concrete and composite bridges. Code of Practice for design of steel bridges (now withdrawn).

### **Sample make-up sheets**

The following fold-out sheets present typical examples of make-up sheets. The examples are:

- (1) A 3-span composite railway bridge, with each track carried by two girders and with a concrete slab acting compositely with the top flange.
- (2) A 3-span haunched composite box girder highway bridge. There are four open-topped steel boxes and the bridge is curved and tapered in plan.





## Main girder connections

No. 2.02

**Scope**

This Guidance Note, together with GN 2.03, covers a number of the typical connection details that occur in the fabrication and erection of a bridge made from steel I girders. The details are representative of those that have been used in practice, but are not the only details that are suitable in all cases. Some details are also appropriate to box girders.

The main girder make-up determines where connections within it are needed and also affects the details that are required. Make-up is covered in GN 2.01.

This Guidance Note covers the connections within the main girder, including the attachment of longitudinal web stiffeners.

Connections between the main girders and bracing or crossbeams are covered in GN 2.03.

The design and detailing of bearing stiffeners are covered in GN 2.04. The connection of intermediate transverse web stiffeners to the main girders is covered, along with their design aspects, in GN 2.05.

Detailing of bolted splices in main girders is covered in GN 2.06. Guidance on how to specify welds is given in GN 2.07.

Guidance on the attachment of bearings is covered in GN 2.08.

**Shop connections in main girder***Splices in webs and flanges*

Shop welded splices in flange and web plates will normally be full penetration butt welds. In most cases, they will be made before the pieces of the girder are put together.

*Flange to web welds* The designer specifies on the drawings the size of weld required between web and flange. Where the shear forces are modest this is often the minimum size that is practically acceptable (6 mm). Fillet welds, rather than butt welds, should be specified between web and flange in almost all situations. See Figure 1. Butt welds require more preparation and are more likely to distort the flange (creating a transverse curvature), as a result of weld shrinkage.

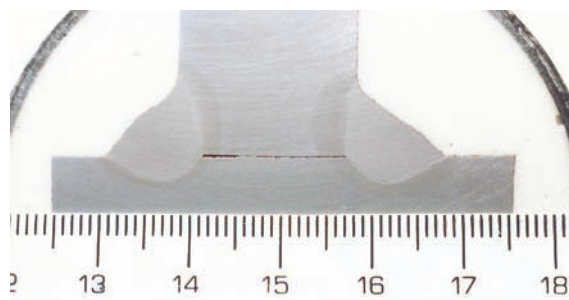

**Figure 1** *Fillet welds to flange*

Only the minimum required size for the weld should be specified, except that a uniform size should be used as far as possible along the whole length of a girder.

Deep penetration fillet welds, as shown in Figure 2, are usually achieved with the submerged arc process using DC positive polarity. They give a greater effective throat than an ordinary fillet of the same measured leg length. The designer should continue to specify weld size in the usual way, but the actual leg length/throat size visible will be slightly less. Because the visible weld size does not indicate the full throat size for such welds, inspection procedures for this type of weld cannot rely on leg length measurements: **strict observance of the weld procedure specification is required.**

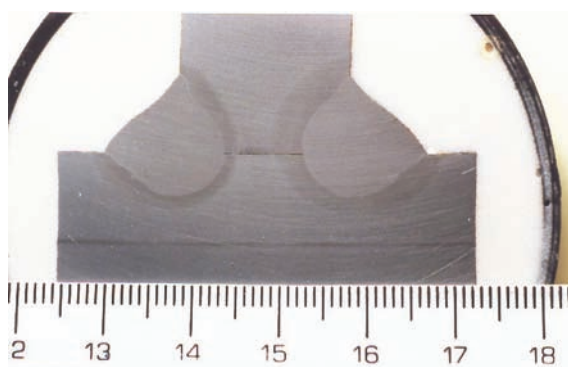

**Figure 2** *Deep penetration fillet welds*

**Changes in flange thickness**

As noted in GN 2.01, changes in flange thickness will usually be made whilst keeping the overall girder depth constant and varying the web depth.

Intentional steps in flange faces at joints need to be treated in the same way as unintentional steps arising from distortions or rolling margins. At a butt welded joint, a better fatigue class can be used where the flange is tapered at 1:4



# Guidance Note

## No. 2.02

or less (see Figure 3). At a bolted joint, the step should normally be all on one side (and appropriate thickness packs used), unless the change of thickness is particularly large.

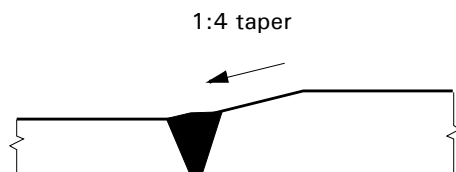

**Figure 3** *Tapered change of flange thickness*

### *Doubler plates*

Where a very thick flange is needed, doubler plates are sometimes used. The doubler plate is fillet welded onto the outer face of the primary flange plate (the plate that is attached to the web), and should therefore be narrower, to allow room for the weld. Where doubler plates are curtailed short of the girder ends, they are tapered in plan, radiused around the end, and tapered in elevation to smooth the stress flow (see Figure 4). (Note also that the tapered portion is not included in the effective section for stress analysis.) However, this is a very low class fatigue detail category and also a 'very severe' detail type for toughness verification. The toughness requirements become especially severe on tension flanges, which in many situations means that it is better to continue the doubler plate to near the girder end, rather than terminate it in the span.

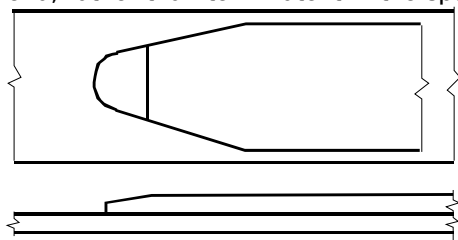

**Figure 4** *Detail at end of a doubler plate*

### **Changes in web thickness**

Webs should normally be dimensioned centrally on the flanges, without any attempt to keep one face aligned through changes in web thickness. Changes of thickness of up to 3 mm each side can be accommodated at a butt weld without any further precautions, as long as the centrelines are aligned. Greater steps should be tapered at 1:4 on each side.

If the web is spliced by bolting at a change of thickness, steps of no greater than 1 mm on

each side can be accommodated without make-up packs.

### **Site splices in main girder**

Connections made on site will either use full penetration butt welds or HSFG bolted joints. Weld procedures for site welds are usually similar to those for shop welds. However, because there will usually be greater limitations on weld positions (the pieces probably cannot be turned) and environmental conditions may be less favourable, the range of suitable procedure may be more restricted.

### *Cope holes in webs*

Where there is to be a site weld across a flange, or where there is a step in the web to suit a tapered change of flange thickness, a semi-circular cope hole is usually provided. See Figure 5. If the web is spliced at the same position, the end of the weld (on the inside face of the cope hole) should be ground flush. Note that a stress concentration factor must be applied when verifying stress range at the open edge of a cope hole; it may be preferable to butt weld an infill piece

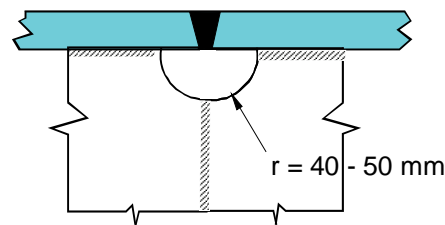

**Figure 5** *Cope hole in web at a flange weld*

### **Longitudinal web stiffeners**

Longitudinal stiffeners are usually only needed on the webs of I-beam girders when the girder is deep and the web is thin. This is most often the case with haunched girders where the web is deeper at the pier positions.

Stiffeners may be either flats or angles. Angles are often used in regions of significant compressive stress because they are efficient in resisting buckling, but it is very difficult to apply, inspect and maintain protective treatment to the inside face of the angle. Where angle stiffeners are used, they should be turned with one leg down, to avoid trapping water and debris.

Longitudinal stiffeners are normally attached by 'all-round' fillet welds. The welds on exposed faces (i.e. other than inside a box girder) need to be continuous, rather than intermittent, and on both faces, to avoid potential corrosion problems.

*Continuous stiffeners*

Longitudinal web stiffeners are usually provided primarily to enhance the shear capacity of thin webs. To participate also in carrying longitudinal stresses, the stiffeners must be structurally continuous. They will usually extend over several 'panels' between transverse web stiffeners.

Transverse stiffeners are usually notched to allow continuous longitudinal stiffeners to pass through (see Figure 6), except at bearing stiffeners, where the longitudinal stiffeners should be attached to the faces of the bearing stiffeners. Where a stiffener is notched, the loss of section should be taken into account in design. EN1993-1-5 limits the cut out to 0.6 of the depth of the stiffener.

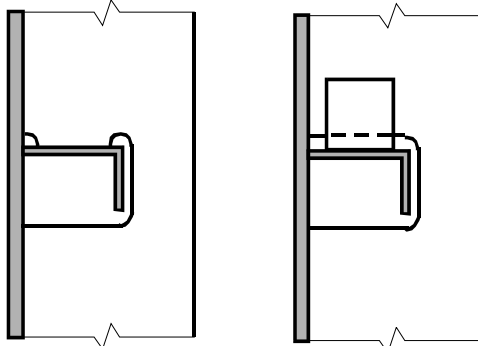

**Figure 6** Notches for longitudinal stiffener

The gap between the stiffener tip and the face of the cutout is usually kept to a minimum for structural reasons, but it must be remembered that protective treatment has to be applied to the faces. A minimum gap of 12 mm (and not less than 1.5 times the stiffener thickness) should be provided, more if possible.

The direct attachment of the longitudinal stiffener to the transverse stiffener is a constraint during fabrication, since the longitudinal web stiffeners are usually attached before the transverse stiffeners. One way to avoid this is by using 'over-width' cut-outs in the transverse stiffener and welding tongue plates to make

the connection (see right hand detail in Figure 6).

Welds between the longitudinal and transverse stiffeners are normally needed only on the back of the stiffener

*Discontinuous stiffeners*

If the longitudinal web stiffeners are only needed to stabilise the web they may be discontinuous. The use of discontinuous stiffeners avoids the extra fabrication work in attaching and welding the two types of stiffener where they meet, but the detail at the discontinuity needs to be considered carefully during design, particularly in regard to fatigue effects.

Where stiffeners are discontinuous, sufficient clearances should be allowed for completing welds and applying protective treatment. A typical arrangement is shown in Figure 7.

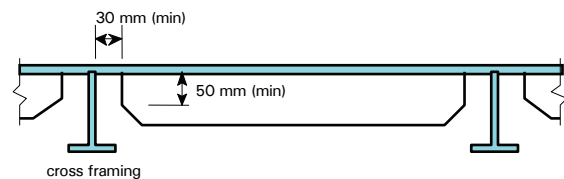

**Figure 7** Discontinuous stiffeners

**References**

- EN1993 Eurocode 3 Design of Steel Structures
- Part 1-1-5 Plated Structural Elements
- Part 1-1-9 Fatigue



### Scope

This Guidance Note covers the attachment of bracing members and cross girders to main I girders, usually achieved by means of connections to stiffeners or cleats on the web of the girder. The details are representative of details that are used in practice, but are not the only details that are suitable in all cases. Some of the details described are also appropriate to box girders.

Additionally, the consequences of the use of the various connections are covered in the Note. The general considerations for design and detailing of web stiffeners are covered in GN 2.04 and GN 2.05.

For guidance on the design of bracing systems, see GN 1.03.

### Intermediate triangulated bracing

Where the main I girders are deep enough, diagonal bracing is normally used, either with a single diagonal or crossed diagonals. See Figure 1.

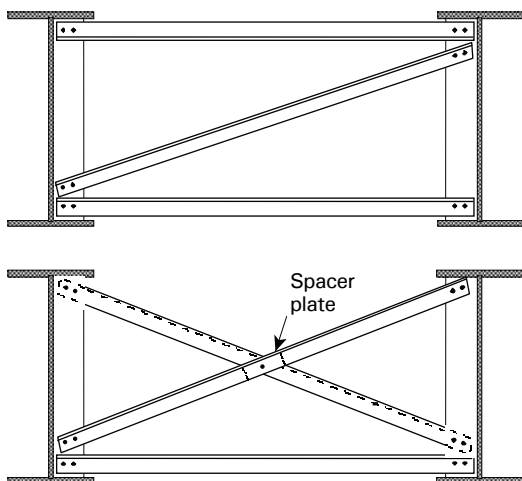

**Figure 1** *Triangulated cross-bracing*

For shallower girders (typically less than 1.2 m deep) where diagonals would be at too shallow an angle to be efficient, either K-bracing (see Figure 2) or 'channel bracing' (see next page and Figure 5) is normally used.

If temporary formwork is used for slab construction, the bracing needs to be sufficiently below the top flange to provide clearance.

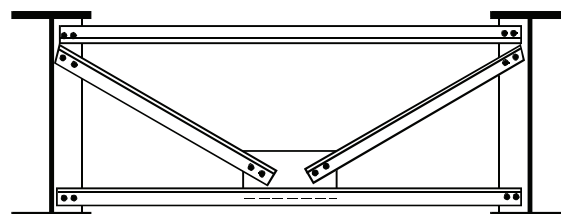

**Figure 2** *K-bracing*

In detailing a connection, moments induced in the stiffeners and bracing members can be minimised by ensuring that:

- the centrelines of bracing and effective stiffener section meet as closely as is practical
- the distance between these intersections and the web flange junction is minimised (but sufficient clearance should be allowed for application of protective treatment, for access to tighten the bolts, or to provide space for slab formwork).

The 'centreline' of a bracing member is, strictly, along its centroid, although for triangulated bracing members the centrelines indicated on drawings are usually taken as the lines of the bolts.

Bracing members are usually attached by bolting. If the stiffener is made sufficiently wide the bracing can connect through a simple lap connection. Typical connections are shown in Figure 3. A 200 mm wide flat stiffener provides sufficient room for a two-bolt connection using M24 bolts. The ends of bracing members should be kept sufficiently clear of the face of the web to allow completion of protective treatment. Similarly, the horizontal leg of the bracing member should be sufficiently clear of the flange to allow access for painting.

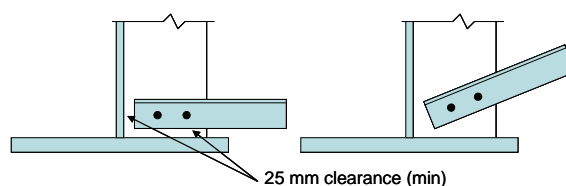

**Figure 3** *Lapped connection of bracing member*

# Guidance Note

## No. 2.03

---

Where two bracing members are bolted to one end of a stiffener, the two members should generally be separately connected. It is not good practice to try to 'economize' by lapping two members on opposite faces of the stiffener using a common group of bolts, because it complicates erection.

If there is insufficient room for the required number of bolts within the width of the stiffener (as chosen for its function as a stiffener), the stiffener may be shaped and extended to facilitate the connection. However, it is advisable not to increase the width over the full height of the stiffener, just to facilitate connections at the ends, because an excessive outstand in the central region will reduce its effectiveness as a stiffener. See Figure 4.

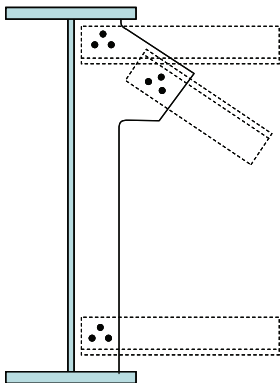

**Figure 4** *Example of a shaped stiffener*

At the crossover of X-bracing it is usual to provide a packing piece (the same thickness as the web stiffener) and a single preloaded bolt through all three pieces. This avoids a narrow gap that is difficult to maintain and achieves a reduction in effective length in compression.

The designer should specify the geometry of the bracing system and the number of bolts at each connection. Either the designer or the fabricator can detail the exact location of bolt holes. Sufficient space should be allowed that the fabricator has some flexibility in detailing hole positions and accommodating tolerances without infringing minimum edge distances.

Where the triangulated bracing provides 'torsional' restraint to the main girders the

web stiffeners to which the bracing is attached should be welded to both flanges (fillet welds are adequate). Note, however, that the stiffener with bracing may attract local load effects as the deck slab deflects under wheel loads giving rise to fatigue problems. The weld size may need to be increased.

Bracing can represent a greater maintenance liability than the main steelwork. This is particularly true of the top horizontal member, which is more difficult to maintain (because of the slab above), is a roosting spot for birds and is also a dirt trap because of the orientation of the angle. (Usually the horizontal leg is at the bottom, to avoid a significant width of plate close to the underside of the deck slab.) Because of this and the potential fatigue problem, horizontal top bracing members should either be avoided or, where used for construction purposes, removed afterwards.

In choosing the arrangement of the bracing itself, consideration should be given to the assembly of the bracing and the space needed for its attachment to the web stiffeners.

### **Gusset plates**

Gusset plates should always be lapped and either fillet welded around the edges or bolted to bracing members, rather than, for example, butt welding a smaller plate onto the heel or toe of an angle. The latter detail is more expensive and requires grinding flush.

With K-bracing, the central gusset may be bolted or shop welded to the bottom tie, leaving the diagonals to be bolted to it during erection. The central gusset will normally be rectangular (the outstand corner may be sniped); there is no saving in shaping it to a V between the diagonals.

### **Channel bracing**

An alternative to triangulated bracing is to use a stiff cross member, usually a channel, to provide torsional restraint to the main girders. A channel is usually chosen because, with flange outstands on one side only, it is easy to lap it onto the stiffener.

Channel bracing requires a moment resisting connection to the girder (see Figure 5). This is usually accomplished by providing a group of preloaded bolts. The web stiffener is normally a simple flat, though it will probably be wider than would be needed as an ordinary intermediate stiffener. If it is over-width, it should be tapered back to the usual limiting width either side of the connection to the channel but such that no welding is required within about 25 mm of the flange edges.

If the channel bracing member is too shallow for an adequate group of bolts, a plate can be welded across the end of the member to provide room for further bolts. A simple full depth plate lapped onto the channel is much easier to fabricate than angle or flat cleats welded to top and bottom, and achieves a flat surface for bolting to the stiffener.

When detailing the extra plate, there should be space for fillet welds all round - the plate should therefore extend slightly beyond the end of the channel, not be flush with it. The outer end of the plate may be flush with the edge of the stiffener or project beyond it; it should not be set back from the edge of the stiffener.

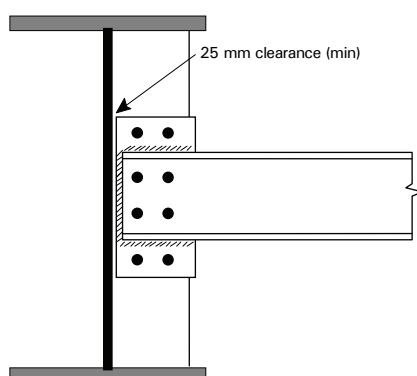

**Figure 5** *Connection of channel bracing*

#### Plan bracing

Lateral restraint is sometimes provided by plan bracing. Angle sections are usually appropriate.

Plan bracing to the top flange, if provided, is usually required only before construction of the deck slab. It will preferably be con-

nected sufficiently below top flange level that it does not interfere with formwork for the slab soffit.

Plan bracing within the depth of the slab is usually connected to the girders by means of cleats welded on the top flange, although this may complicate the positioning of shear connectors and the fixing of slab reinforcement. For these practical reasons, bracing within the depth of the slab is best avoided.

Connection of plan bracing below top flange level is best achieved through cleats welded into the corner between web and a transverse stiffener (Figure 6). Consideration should be given to balancing local moment effects at the connection by careful choice of orientation of bracing members. Such bracing is usually removed after the slab is cast, to avoid the need for future maintenance.

Plan bracing to the bottom flange is not normally needed unless overall torsional rigidity of the bridge is required to enhance aerodynamic stability or to form pseudo-box girders. If it is used, a detail similar to that in Figure 6 should be appropriate.

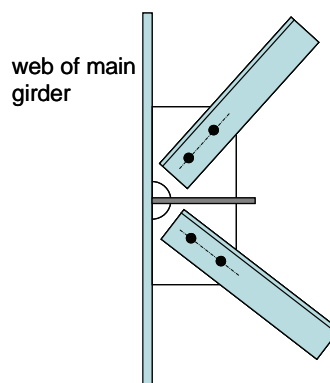

**Figure 6** *Connection of plan bracing*

#### Support bracing

Bracing at supports may be triangulated or channel bracing. Similar considerations as for intermediate bracing generally apply, though the design loads and thus the member sizes are larger. Additionally, this bracing will often act as a trimmer beam at the end of the slab.

Where the supports are at a significant skew to the line of the bridge, the deflection of the

# Guidance Note

## No. 2.03

---

girders and the bracing during construction must be considered carefully. Effectively, the bracing plane tends to rotate about a line through all the bearings, which results in a twist to the main girders. The designer must make it clear at which stage the webs are required to be truly vertical, as this will determine the geometry of the bracing. See GN 1.02.

In some designs, a reinforced concrete diaphragm is provided at end supports. This reduces the amount of exposed steelwork in an area where access for maintenance can be difficult, and where water penetration through deck joints can lead to corrosion - especially where unpainted weather resistant steel is used. With concrete diaphragms, light bracing may still be needed for construction. Holes in the webs of main girders for reinforcing bars should be large enough to allow plenty of room for fixing the reinforcement. Shear stud connectors are often provided on the webs of the main girders to ensure that the concrete does not shrink away from the face of the web. Consideration should be given to the use of weather flats at steel-concrete interfaces.

Where channel bracing acts as a trimmer, shear connectors are normally provided, to generate composite action of the trimmer beam.

High skews lead to difficulties for access (into the acute corner) for welding the bearing stiffeners unless they can be arranged square to the web. The size of the fillet weld in the obtuse corner needs to be considered carefully. See GN 2.04.

### End connections in integral bridges

At the ends of integral bridges, the ends of the steel girders will normally be cast into the abutment (either capping beam or end-screen wall detail). As for reinforced concrete diaphragms for non-integral bridges, light bracing (which will probably get cast into the abutment) will usually be necessary for the construction condition. Holes are needed in the web for reinforcing bars to pass through, and shear connectors will be needed to assist in transmitting the moments and forces.

### Connection of 'ladder deck' cross girders

The steelwork system in ladder decks generally comprises two main longitudinal girders and equally spaced cross girders arranged to span transversely between the main girders (like the rungs of a ladder). The cross girders are usually arranged orthogonal to the main girders, but for small skews ( $<15^\circ$ ) can be parallel to the line of the supports. The cross girders will usually be fabricated I sections, although in some instances it may be possible to use a rolled section. The concrete deck slab acts compositely with the main girders and the cross girders. There are shear studs on the top flanges of the main girders and the cross girders.

With a deck slab of uniform thickness, the top flange of the cross girders will line up with the top flange of the main girders. If the slab is haunched over the main girders, the top flange of the cross girders will be set up higher than that of the main girders. This is often done to provide extra depth at the root of the slab's edge cantilever if the cantilever is long. Usually on ladder decks the cross girders are provided only between the main girders, however they may be extended as cantilevers on the outside face of the main girders. This means that, assuming a full width pour, the steelwork supports the entire deck slab in the wet concrete condition.

There are two methods in general use for connecting the cross girders to the main girders. With a lapped connection, the web of the cross girder is lapped on one side of a stiffener on the main girder as shown in Figure 7. With a splice plate connection, the web of the cross girder is aligned with a stiffener on the main girder and double cover plates are used as shown in Figure 8. Use of end plate connections where an end plate welded onto the cross girder is bolted to the web of the main girder is not recommended, because of the difficulty in fit-up.

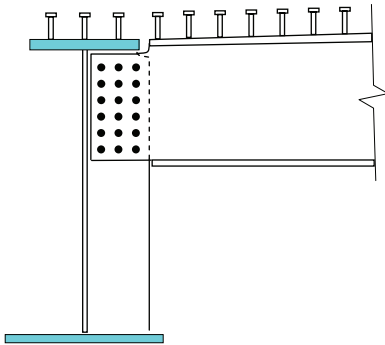

**Figure 7** *Cross girder lapped connection*

The connections are more simply designed so that only a bolted connection to the cross girder web is required. This simplifies the steelwork erection. It is not necessary to make any connection between the cross girder top flange and the main girder top flange, or the cross girder bottom flange and the main girder web stiffener, although the addition of a top flange cover plate connection is sometimes useful to reduce the effective length of the cross girder. In the bare steel condition, the connection must have adequate capacity for the wet concrete loads, after which the composite top flange will provide additional capacity for subsequent stages of loading. If need be, the web of the cross girder can be strengthened by welding on additional plating in the region of the bolt group.

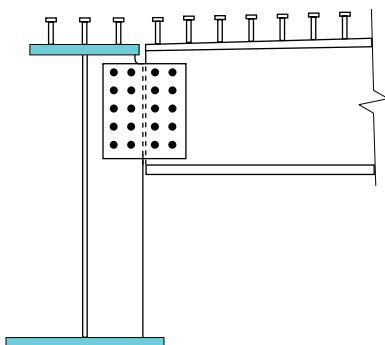

**Figure 8** *Cross girder splice plate connection*

At internal supports of continuous multi-span bridges, the standard cross girder can be adapted to provide restraint to the main girder bottom flange at the support and, if needed, within the hogging moment region. This can be achieved by the introduction of bracing members or by increasing the depth of the cross girder (see Ref 1). Similar arrangements can be used at the abutments or end supports. At internal supports to skew decks, with judicious spacing of the cross girders, the bearings under the main girders can be arranged so that they are staggered by a multiple of the cross girder spacing. At a skew abutment the cross girders can be connected into a heavier end trimmer girder that is parallel to the line of the bearings. Where the skew is heavy, the trimmer to main girder connection may also be subjected to significant hogging moments and the design and details developed accordingly.

#### References

1. Composite highway bridge design (P356), The Steel Construction Institute, 2009

#### Further reading

Hayward and Weare, Steel detailers' manual, Second Edition (revised by Oakhill), Blackwell Science, 2002.  
Hayward, Sadler and Tordoff, Steel bridges (34/02), BCSA, 2002.





**Scope**

This Guidance Note gives information about practical detailing for bearing stiffeners for plate girder bridges without longitudinal stiffeners. The support positions of box girders usually require plated diaphragms; diaphragms and their stiffeners are outside the scope of this Note.

**General**

This Note describes first the general design requirements for stiffeners, then explains the practicalities of certain details and finally shows what the consequences of these practical considerations are on the design details.

**Design requirements**

Although bearing stiffeners are not explicitly required by EN 1993-1-5, the requirements for resistance to transverse forces at supports makes them inevitable in most cases. Figure 5.1 of EN 1993-1-5 illustrates end supports with rigid and non-rigid end posts as well as no end posts; arrangements at intermediate supports of continuous girders are not illustrated.

Detailing of stiffeners is covered in EN 1993-1-5, 9.3.1 and 9.3.2, which presume double-sided stiffeners; it is not stated that the stiffeners should be symmetric about the web but when the arrangement is not symmetrical, the designer must take into account the effect of the resulting eccentricity.

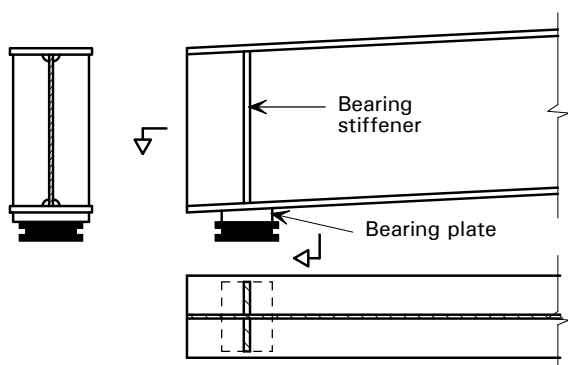

**Figure 1** Arrangement at a support bearing

The usual support arrangement is for the bridge girder to be placed with the bottom flange seated on top of the bearing (see Figure 1). A tapered bearing plate, sometimes known as either a 'sole plate' or a 'seating plate', is nearly always required between the upper surface of

the bearing and the underside of the flange so that the bearing remains truly horizontal. With this arrangement the load path for the transfer of the bearing reaction to the girder is through the thickness of the bottom flange plate and into the effective section of the stiffener acting with a portion of the web plate on each side of the stiffener. The axial force in the stiffener will be at a maximum immediately above the bearing and is dissipated over the length of the stiffener as load is shed into the web.

The bottom edge of the bearing stiffener should be closely fitted to the bottom flange so that the transfer of load at the ultimate limit state may be assumed to be in direct bearing between the parent metal of the stiffener and the upper surface of the bottom flange. It is not economical to provide a bearing fit between web and flange in a fabricated girder, so the web should not be specified to be fitted locally and should not be included in the bearing area. (The flatness tolerance for plates is such that small ripples up to 3 mm deep can be formed during rolling; considerable extra work would be needed to match the web to the flange where there are such ripples.)

As there is no residual axial force in the stiffener where its top edge meets the underside of the top flange, there is usually no need for the top edge of the stiffener to be closely fitted to the flange.

Edges which are required to be fitted should be clearly indicated on the drawings.

As well as being required to carry the axial force from the bearing reaction, the stiffener must also resist bending moments arising from eccentricity of the axial force (relative to the centroid of the stiffener section), flexure of the end frame, and horizontal loading. It is in order to resist these forces that the stiffener should be adequately connected to the top flange (as well as to the bottom), although this does not mean that it has to be fitted. Attachment to the top flange of a deck-type bridge also provides torsional restraint to the flange plate (see comment in GN 2.05).

Eccentricity of the axial force can arise from a number of causes, including thermal expansion/contraction, bearing misalignment, beam rotation

# Guidance Note

## No. 2.04

---

under load, substructure movement and shrinkage/creep of composite decks.

On long continuous decks, the range of movement remote from the fixed bearing can be significant. In such a case, the eccentricity of the bearing reaction to the stiffener centroid can lead to large bending moments in the effective stiffener section. This is usually accommodated either by using multi-leg stiffeners, or by mounting the bearing 'inverted' (if of the sliding type) so that the bearing remains fixed in position relative to the superstructure steelwork.

The movement is then relative to the substructure, which can more easily accommodate eccentric loading. However, when the bearing is mounted inverted, the sliding surface will be facing upwards instead of downwards, and it is therefore desirable to specify that the bearings are shrouded to prevent the ingress of harmful debris.

Multi-leg stiffeners may also be necessary on haunched girders where there is a change of direction of the bottom flange either side of the bearing. It is advisable to design the connection between such stiffeners and the flange to resist the tensile force due to the change of direction of the flange plate, ignoring the bearing reaction.

This will cater for situations where the load path from the bearing does not spread to the stiffener as a result of extreme thermal movement and during jacking for bearing replacement.

### Practicalities of fabrication

For the designer, the main consideration is the type of welds that should be specified at the three edges of the stiffener that are connected to the girder. These connections are:

- stiffener to web
- stiffener to flange adjacent to the bearing
- stiffener to flange remote from the bearing.

The connection to the web will normally be the first edge welded. Fillet welds should be sufficient in most cases. Full penetration butt welds are unlikely to be necessary and are undesirable; the cruciform detail (stiffeners on either side of the web) creates restraint during welding and can result in lamellar tearing.

The connection to the bottom flange is normally the most heavily loaded part of the stiffener.

The stiffener can be 'fitted' to the flange such that there is very little gap between the end of the stiffener and the flange before welding, and this is a normal feature of the fabrication process. Where the stiffener is fitted, the majority of the load is transmitted in direct bearing, so a full penetration butt weld is unlikely to be necessary for ULS loads.

The requirements in EN 1090-2 for surfaces finished for full contact bearing are given as functional tolerances in Table D.2.7. Two classes of functional tolerance are given and class 1 is usually specified. However, the MPS [Ref 3] enhances the class 1 tolerance for fitted surfaces and in particular requires that, where the ends of stiffeners are required to be fitted, the surfaces shall be ground where necessary so that the maximum gap does not exceed 0.25 mm over at least 60% of the contact area (see MPS 6.801).

The fatigue detail categories in EN 1993-1-9 do not include the case of a fitted stiffener transferring compressive forces. It is recommended that the previous practice (according to BS 5400-10) is used - assume that all the fatigue range of force is transferred through the weld throat area. The EN 1993-1-9 detail category for this is 36 (Table 8.5). This recommendation might lead designers to choose a butt weld detail in preference to fillet welds. However, it is advantageous to avoid a full penetration butt weld, because shrinkage strains (vertically) will distort the transverse profile of the flange (see Figure 2) and cause misfit of the bearing. Where the bearing stiffener is thick, it might be helpful to specify a partial penetration weld, as this will reduce the area over which fitting is to be achieved and the amount of weld metal to be deposited.

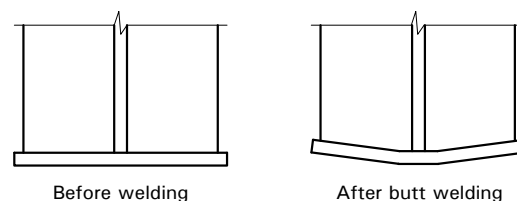

**Figure 2** Distortion due to butt welding (exaggerated)

To provide proper fitting at the stiffener to top flange connection as well as at the bottom

flange is difficult, because it requires a tight fit between two nominally parallel faces. A fillet weld connection to the top flange will normally be adequate structurally. Where gaps occur at the top flange as a result of fitting to the bottom flange, the size of the fillet welds may need to be increased (see Figure 3).

If bearing stiffeners are skew to the web, it may be more difficult to fit them to the bottom flange, because (as noted above) plates may have a small ripple due to rolling; this ripple is too small to have any structural significance but may cause problems in achieving the close fit if the flange is wide and the skew is large.

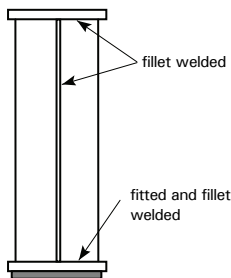

Figure 3 Connection of a bearing stiffener

Cope holes may be used to clear root fillets or web/flange welds, as for intermediate stiffeners (see GN 2.05), although this may detract significantly from the bearing area at the bottom flange and is best avoided there.

Skew stiffeners also complicate the welding detail at the connection to the web. If the skew is any more than 30° the fillet in the acute angle (which is then less than 60°) will not achieve full root penetration. EN 1993-1-8 gives a method for calculating the throat thickness in this situation. (The *necessary reduction in the throat at acute and obtuse angles must not be overlooked by designers*). Specifying the weld throat, rather than the leg length, is a better way of ensuring that sufficient weld is provided.

When the bearing reaction is very eccentric from the web (for example above a knuckle bearing which is providing torsional restraint to the main girder), Tee stiffeners may be specified, but this does add considerably to the task of welding and to the difficulty of the application of protective treatment.

Where there are multiple stiffeners, it is inevitable that some pieces will have to be welded once other pieces have been attached. To ensure adequate welding, there must be access for the operative to lay the weld, access for visual inspection and NDT, and, in the case of unacceptable defects, access to remove the defects and to repair. *As an approximate guide*, the clear line of sight to the root of a fillet weld should make an angle to the face of the web of preferably no more than 30°, and in all cases no more than 35°. See Figure 4. This would allow access for a gloved hand holding an electrode and a line of sight for a welder wearing a mask. For a partial penetration weld the line of sight should be no more than 20° to the web (but better still, avoid partial penetration welds in these circumstances).

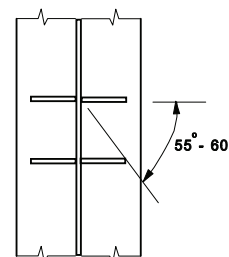

Figure 4 Double leg bearing stiffener

Where stiffeners of the closed-box type are specified, they may either be pre-assembled before fitting to the web, or they may be built up piece by piece. In either case, it is not possible to lay welds at every corner on each face, because closed spaces are created. The detail chosen by the designer will effectively determine the sequence in which the box must be built up; the constraints inherent in the implied sequence should be considered carefully at the design stage. A typical simple configuration is shown in Figure 5; in this example, the two outstands are welded first and then the closing plate is fillet welded to the tips of the outstands.

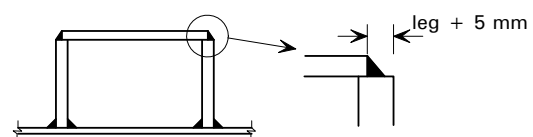

Figure 5 Attachment of typical box-section stiffener

Support at bearings

# Guidance Note

## No. 2.04

---

Careful consideration has to be given to the load path between the girder and the bearing itself. There are normally two interfaces to be considered:

- a) bottom flange to bearing plate, and
- b) bearing plate to bearing.

The top plates of proprietary bearings are usually machined to a flatness better than the tolerance given in EN 1090-2 for bearing surfaces. The design of the bearing normally assumes that load is applied to the top evenly or (for bearings resisting rotation) in a linearly varying fashion, i.e. there are no stress concentrations. High strength epoxies between the underside of the girder and the top of the bearing are also used to achieve a uniform load distribution. The bottom of the bearing plate should therefore also be machined to tolerance class 1 in Table D.2.7 of EN 1090.

The other interface, between bottom flange and bearing plate, needs careful consideration. The top of the bearing plate is often machined, because it is tapered to suit an inclined soffit and horizontal bearing top surface. However, if the bottom flange were machined before fabrication, that would not guarantee a surface within the EN1090-2 tolerance limit, because of subsequent distortions due to welding. On the other hand, machining the bottom flange of a completed girder is impractical. In any case, machining the flange removes flange thickness in a highly stressed region and this is likely to incur the penalty of a thicker flange to allow for the loss.

If a good fit is not achieved between the bearing plate and the bottom flange, the load will be transferred unevenly. It may be possible to show that, no matter where the load is transferred at this interface, the spread of load<sup>‡</sup> through the plates on either side of the interface is sufficient to ensure that the bearing and the web or stiffener forming part of the effective bearing stiffener are not overstressed. However, in most situations this will not be the case, so this interface will often need to achieve a tolerance equivalent to a machined surface; this can be achieved by grinding the bearing plate or bottom flange of the girder (see *Model*

*Project Specification*), to ensure even bearing. This tolerance only has to be achieved over that part of the interface defined by a cruciform area equal to the width of stiffeners or web plus 45° spread through bottom flange.

### Through-thickness performance

Where large transverse loads are carried through the web (usually as a result of diaphragm action or crosshead details), the web may have to be fabricated with material with guaranteed through thickness properties. See GN 2.09 and GN 3.02.

### Summary for design

Fillet or partial penetration butt welds, rather than full penetration butt welds, should be specified for the stiffener to bottom flange connection. For design to EN 1993, the designer should ensure that the following are adequate:

- cross sectional resistance of the full effective section to carry full axial force plus moment
- buckling resistance of full effective section, to carry the maximum load in the middle third of the stiffener
- bearing strength to carry full axial load and moment on the section within spread lines from the bearing over that area of web and stiffeners that has been fitted or butt welded to the flange
- fatigue resistance for the stress range due to forces carried through welds between flange and stiffener, based on the section determined by spread from the bearing and ignoring direct bearing
- resistance of welds (in shear) between stiffener and girder web, to transfer the forces between the stiffener and the web
- resistance of the welds between the stiffener and the top flange, to carry lateral forces (restraint forces, wind forces, etc.).

### References

- 1 EN 1993 Eurocode 3. Design of steel structures  
EN 1993-1-5 Plated structural elements  
EN 1993-1-9 Fatigue
2. EN 1090-2 Execution of steel structures and aluminium structures. Technical requirements for steel structures.
3. Steel Bridge Group: Model Project Specification (P382), SCI, 2009.

---

<sup>‡</sup> EN 1993-1-5 clause 3.2.3 sets the spread angle through a flange as 45 degrees.

### Scope

This Guidance Note gives information about the need for intermediate transverse web stiffeners for plate girder bridges and summarizes the practical detailing aspects.

Stiffeners used as part of a U-frame in half-through construction require additional considerations that are not covered in this Note.

This Note first describes the main purpose of intermediate transverse web stiffeners, then describes their secondary role in the context of intermediate restraints. It then explains the practicalities of certain details and the influence of these details on the design and cost of fabrication.

### Primary purpose of intermediate web stiffeners

Where universal beam sections provide adequate bending resistance, they could, in theory, normally be used without any intermediate web stiffeners (in the absence of any need for intermediate systems of restraint to compression flanges). This reflects the inherent stability of webs in such sections and the general ability of the section to sustain significant levels of plastic strain before attainment of ultimate load (i.e. the section classification is generally Class 1 or 2).

The two key factors determining the stability and hence the resistance of webs are: web slenderness (the  $h_w/t$  ratio) and the aspect ratio of web panels (the  $a/h_w$  ratio) - see Figure 1. Web resistance reduces as these two parameters increase. The transverse bending resistance of the flanges has a secondary influence that is only significant at close stiffener spacing.

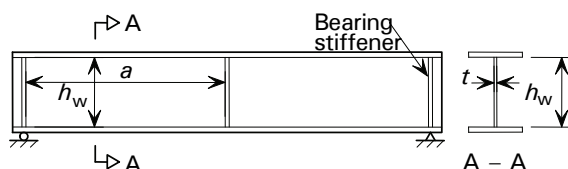

**Figure 1** Web slenderness  $h_w/t$  and web panel aspect ratio  $a/h_w$

Plate girders are generally different from universal beams in relation to web stability. The designer's freedom to proportion the component plates of such girders frequently means

that  $h_w/t$  ratios can be relatively high. This, coupled with high aspect ratios ( $a/h_w$ ) for web panels would result in low web resistances in shear and bending; the overall resistance of the girder would therefore be reduced.

From the above, the primary role of intermediate web stiffeners is clear: they serve to divide the web into panels and thereby reduce the web panel aspect ratio. This increases web resistance.

The maximum resistance achievable in a web occurs if its geometric characteristics ( $h_w/t$ ,  $a/h_w$ ) are such as to permit the development of full plasticity. Even where this is not possible, shear buckling involves a large post-buckling reserve beyond initial elastic buckling. This is an ultimate condition in which tension bands develop and ultimate failure of the web is by yielding of these bands as they rotate to develop the optimal resistance - see Figure 2. Final collapse involves the flanges pulling into the plane of the web and this mechanism contributes some additional shear resistance (the flange contribution in EN 1993-1-5, cl 5.4) and also develops some force in the stiffeners.

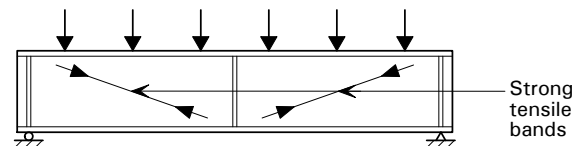

**Figure 2** Development of tensile bands in the girder shown in Figure 1

On deck-type bridges, intermediate stiffeners are usually avoided on the exposed face of the outer girders for aesthetic reasons. For half-through railway bridges, the intermediate stiffeners are located on the outer face of the girder in order that the gap under the top flange on track side can, if necessary, be used as a refuge.

Secondary roles of intermediate web stiffeners In addition to their role in determining web panel sizes and being active in the development of tension field action, intermediate web stiffeners are frequently required to play two further roles:

- To permit attachment of bracing between beams/girders.
- To act as load bearing stiffeners to the web at points of stationary concentrated load-

# Guidance Note

## No. 2.05

---

ing on the beam/girder. This is not common in bridges, except for occasional applications during erection when it is necessary to apply concentrated loads to the girders, such as from crane outriggers.

The first of these roles is discussed in the context of detailing below. The second is an aspect that is taken into account in the design verification in EN 1993-1-5, 9.1.4.

### Economy in design

The amount of workmanship in stiffener assemblies is disproportionately high compared to the other components in a typical bridge girder. The cost of stiffening work varies considerably among fabricators, depending on their particular investment strategies and the processes used. However it is often the case that selecting a thicker web and reducing the number of stiffeners will lead to a cheaper girder. As automation of stiffener welding develops, this will become a less dominant consideration.

Care needs to be exercised in relation to the proportioning of webs and stiffeners if the most economical girder configuration is to be achieved.

### Stiffener layout and detailing

#### *Simple intermediate web stiffeners*

A typical arrangement for a simple single intermediate web stiffener is a flat welded onto one face of the web and connected to one flange (see Figure 3).



**Figure 3** *Simple web stiffener*

Flat stiffeners are usually preferred as they are easily welded onto web plates using all-round fillet welds. They are normally attached after the web has been joined to the flanges (with automatic girder welding they have to be attached afterwards, since they would obstruct the passage of the welding heads).

Traditionally, web stiffeners have had to be attached and welded manually, though robotic equipment is now becoming available that can weld them automatically after they have been positioned and tacked manually.

No more stiffeners should be specified than are actually necessary for structural adequacy - by any method of fabrication they are relatively expensive items.

Flat stiffener outstands (width of the flat) are limited by the criterion in EN 1993-1-5 cl 9.2.1(8), to prevent torsional buckling; this limits the outstand to  $10.5t_s$  for S355 steel. Commonly used sizes include:

- 100 x 10 or 12 mm
- 150 x 15 mm
- 200 x 20 mm
- 250 x 25 mm

At the top flange, attachment of the stiffener to the flange is not strictly necessary for its function as a web stiffener. Where the top flange is composite, the stiffener should be attached, to provide torsional restraint to the flange. Fillet welds are generally sufficient for attachment.

Only the minimum weld required for strength should be specified between any web stiffener and the flange (subject to a practical minimum size of 6 mm). Even fillet welds introduce some local distortion of the flange, though much less than would be introduced by a butt weld. However, with a thick flange ( $T > 50$  mm) it may be the choice of the fabricator to lay a bigger weld than specified to avoid the necessity for local preheat, which can itself lead to distortion. Where bracing is attached to the stiffener, however, moment is attracted out of the slab and into the stiffeners and this may require larger welds between stiffener and flange to provide adequate fatigue life.

At the bottom flange, a clear gap should be left, preferably about 3 times the web thickness, but not more than  $5t$ . This accommodates tolerances in depth of both the web and the stiffener, whilst not being sufficient to lead to fatigue problems at the stiffener end (except possibly where the shear resistance relies heavily on the flange contribution, in which situation stiffener axial force is

induced - it is better to attach both ends in such cases). The free corner of the stiffener is often scarfed, which facilitates the application of protective treatment, as shown in Figure 4.

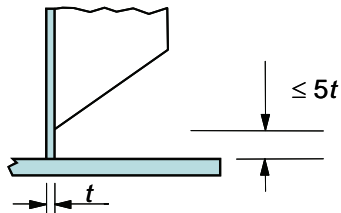

Note. Scarf angle typically 45°

**Figure 4** Detail at stiffener bottom

The shape of web stiffeners attached to a flange must allow for the fillet weld between web and flange. One way of achieving this is by use of 'cope holes'. These are circular quadrants cut out of the right angle to leave a clear gap (see Figure 5). A radius of at least 40 mm, preferably 50 mm, is needed to allow welds to be returned around the corners and protective treatment to be applied to the inner faces of the hole (although the standard of cleaning can never be as good as on a plane face).

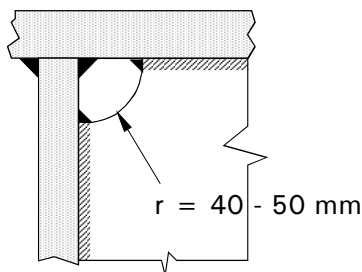

**Figure 5** Cope hole detail

Alternatively, some fabricators prefer to cut stiffeners square then grind the corner of the plate so that it just clears the weld. The fillet welds to the stiffener can then continue without stop/start, from web to flange (see Figure 6). This avoids creating areas that are difficult to give proper protective treatment, though on bottom flanges it can create corners that trap debris and moisture. Where weathering steel is used, cope holes should be provided in the stiffener at the bottom flange, of at least 50 mm radius, to avoid these moisture traps; this recommendation is given in GN 1.07.

Sniped corners (45° cut across the internal corner) have been used by some designers in this location, but the detail should be avoided, because it is very difficult to return the weld (i.e. in the acute angle, across the thickness of the stiffener) and protective treatment cannot be applied satisfactorily to the inner edge of the stiffener or the weld return.

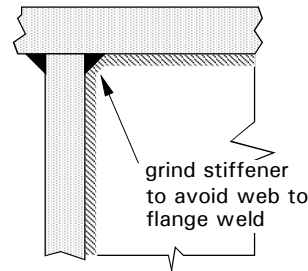

**Figure 6** Alternative stiffener detail at corner

The weld attaching an intermediate or other web stiffener (i.e. across the flange and around the edge) should not have its toe closer than 10 mm to the edge of the flange for good fatigue detailing, although EN 1993-1-9 does not penalize lesser clearances. It is wise to choose a stiffener width at least 25 mm less than the nominal flange outstand to ensure that this clearance is achieved in practice. If it is necessary to use wider stiffeners, perhaps to suit bracing, they can be scarfed at the ends, or a quadrant notch (similar to the cope hole detail) could be made, as shown in Figure 7, so that the weld is clear of the edge of the flange.

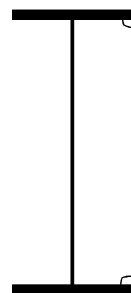

**Figure 7** Stiffener shaped to avoid welding close to edge of flange

### Intermediate stiffeners for the attachment of bracing

#### Stiffeners for triangulated bracing

Flat stiffeners are well suited to simple and inexpensive attachment of bracing members. However, as noted in GN 2.03, they may need to be shaped to suit attachment details.



# Guidance Note

## No. 2.05

---

### *Attachment to flanges*

The stiffeners are a means of transmitting torsional restraint to the beams and they should therefore be attached to both flanges. Fillet welds are quite adequate for this purpose.

### *Stiffeners for 'channel' bracing*

Again, flat stiffeners are preferred for attaching channel bracing, though they will probably be more substantial than those used with triangulated bracing, since a moment restraint has to be provided and a larger group of bolts is needed to transmit the moment. Stiffeners are sometimes shaped to provide extra space for the bolt group. See GN 2.03.

### *Treatment of skew*

Small degrees of skew of bracing members can easily be accommodated by suitable alignment of the flat stiffener, but it is normally just as easy, and cheaper, to detail orthogonal bracing. Highly skewed bracing should always be avoided, because it introduces difficulties in fabrication as well as being less effective as intermediate bracing. See GN 1.02 for guidance on skew bridges.

### **Notching for longitudinal stiffeners**

Guidance on notching of transverse stiffeners to accommodate longitudinal stiffeners is given in GN 2.02.

### **Summary of web stiffener layouts**

The layout of common arrangements of intermediate web stiffeners, and comments on detailing, are summarized in Table 1. The Table indicates the suitability of different shapes for different purposes.

Each bridge will merit individual consideration as to the most effective and economic arrangement and geometry of stiffeners. The Table should, however, act as a general guide. Further detailed guidance is given in GN 2.03.

### **Reference**

EN 1993-1-5:2006, Eurocode 3 – Design of steel structures: Part 1-5 Plated structural elements.

**Table 1** Typical intermediate web stiffener configurations and detailing advice

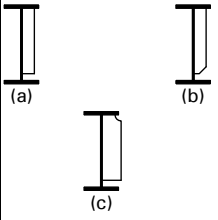
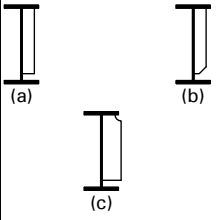
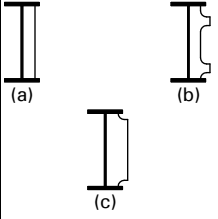
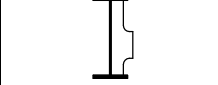
Type		Suitable for:			Attachment to flanges	Shape of stiffener	Weld to web	Weld to flanges	Detail in corners
		Dividing web panels	Triang'd bracing	Single cross-beam					
1		Yes	No	No	To one flange only  Gap $3t$ to $5t$ at unattached end.	a)rectangular b)scarfed at free end c)cut back at attached end  All from flat $h_s/t_s \geq 10$	Fillet weld  As small as possible (6 mm min)	Fillet weld  As small as possible (6 mm min) Weld toe at least 10 mm <sup>(1)</sup> from edge of flange	Circular cope hole (40 mm radius min) or sniped in corner and welded around <sup>(2)</sup>
2		Yes	Yes	No	To both flanges	As (a) or (c) above, or shaped plate, or (a) or (c) plus gusset	As above	As above. Butt welds and end preparation not necessary	As above
3		Yes	No	Yes	To both flanges	Shaped plate, $h_s/t_s \geq 10$ outside lapped region	As above	As (2) above	As above

- Notes:
1. The 10 mm clearance is required to avoid a reduction in fatigue performance although failure to comply is not specifically penalized in EN 1993-1-9.
  2. The stiffener weld overlapping the longitudinal flange/web weld is now a widely accepted detail and is not considered to carry a fatigue penalty.
  3. Minimum sizes may need to be increased if there are gaps, for example between one end of a stiffener and the flange where the stiffener is attached at both ends.
  4. Welds should normally be continuous and all round the stiffener.



**Scope**

This guidance note covers the design and detailing of connections made with preloaded bolts in slip-resistant connections. For comments on size, position and drilling of holes, see GN 5.08; for comments on installation, see GN 7.05; for comments on protective treatment, see GN 8.01.

Comments are given in relation to shear connections, where the connection transfers force from one component to another in shear across the interface. Girder splices, with single or double cover plates, and lapped connections, such as at the end of ladder deck cross girders, are shear connections.

**General**

For design to the Eurocodes, the relevant bolt standard is EN 14399. This Standard is in 10 Parts and covers hexagon head bolts of type HR and HV, HRC bolts (commonly seen in the UK in the form of TCB bolts) and Direct Tension Indicators (traditionally known as load indicating washers). HV bolts are not used in the UK.

A useful reference on the design of bolted connections is Owens & Cheal (Ref 2).

**Benefits of using preloaded bolts**

The advantages of preloaded bolts over other types of bolts are:

- rigidity of joints (no slip in service)
- no loosening of bolts due to vibrations
- better fatigue performance
- tolerance for fabrication/erection (because of the use of clearance holes)
- familiarity within industry.

The actual disadvantages are minimal, but the perceived disadvantages quoted by some designers are:

- difficulty of ensuring that all bolts are adequately preloaded
- In double cover connections, small differences in ply thickness in plates of nominally the same thickness can result in the preload from bolts near the centre of joint being applied to the wrong side of the joint, see Figure 1.

These 'disadvantages' are generally overcome by ensuring a good standard of fabrication, attention to plate thickness tolerances and by following erection procedures that recognize the potential problem.

Plates tend to span from C to D, therefore part of preload in this row is applied to plate A instead of plate B

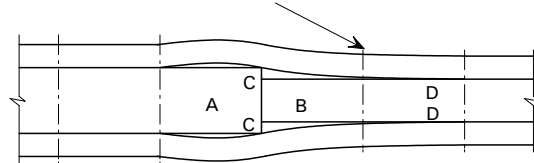

**Figure 1** Lack of fit in a double cover plate splice

**How a preloaded connection works**

The bolts are tightened such that a high tension (usually beyond yield) is developed in the bolts. The plates of the connection are thus clamped together so that shear transfer between the plates is achieved through friction.

**Design according to the Eurocodes**

EN 1993-1-8 defines two types of slip resistant bolted shear connection:

- Category B: Slip resistant at SLS. The connection can slip into bearing shear at ULS.
- Category C: Slip resistant at ULS.

Rules for determining slip resistance and bearing shear resistance for individual bolts are given in EN 1993-1-8 and are not discussed further here.

**Choice between categories B and C**

Most preloaded bolted connections are designed as category B, which generally requires fewer bolts. However, category C connections, with no slip at ULS are chosen in certain circumstances:

- If oversized or slotted holes are specified or are expected to be needed for greater accommodation of tolerances during erection
- Where rigidity of the joint is required at ULS (e.g. sometimes at U-frame corners when its stiffness needs to be increased).

# Guidance Note

## No. 2.06

### Connection design

Designers almost always use linear elastic analysis to determine forces on the individual bolts (i.e. force on each bolt is proportional to its distance from the centre of rotation for the group), although this is only explicitly stated for forces at ULS in Category C connections and in bearing/shear connections where shear resistance governs.

Double shear should be used where possible, because:

- the contribution of each bolt is doubled
- cover material can be evenly disposed either side of the member being spliced, thus avoiding eccentricities at the connection.

For any bolted joint, the following need to be considered in design:

- maximum force on a bolt (shear, and/or external tension)
- stresses in the part joined (the parent plate)
- stresses in cover plates.

Compression member splices and compression flange splices are verified for:

- The design forces applied to the member but with axial force increased to allow for second order effects when the splice is not near a lateral restraint (note that this is not applicable for composite flanges).
- The design resistances of the cover plates are evaluated as compression elements and thus  $\gamma_{M0}$  applies and there is no deduction in area of section for bolt holes, unless the holes are oversized or slotted .

Tension member splices and tension flange splices are verified for:

- The design forces applied to the member
- The design resistances of the cover plates evaluated as the lesser of the plastic resistance on the gross area (not deducting for holes) and the ultimate resistance of the net section (after deducting for holes). The factor  $\gamma_{M0}$  applies in the former case and the  $\gamma_{M2}$  factor applies in the latter case.

Web splices are verified for:

- The design values of the shear, axial and bending effects on the web (i.e. no shed-

ding of moment from web to flanges is allowed) and taking account of moments caused by the eccentricity of the connection

- When the predominant stress is compressive, the design resistances of the parent plate and cover plates are evaluated as compression member
- When the predominant stress is tensile, the design resistances plates are evaluated as tension member (therefore holes are to be deducted).

### Detailing the connection

Careful detailing can result in material savings, easier erection and a more durable structure. Minimum and maximum spacing, edge and end distances are given in Table 3.3 of EN 1993-1-8 and the following additional comments should be noted.

- Add 5 mm to 10 mm to the minimum pitch to give greater clearance for tightening.
- Add 5 mm to the minimum edge and end distances if possible (see also GN 5.08).
- The minimum edge and end distances are to ensure adequate load transfer without slip and adequate bearing/shear in a slipped joint at ULS.
- The maximum pitch and edge distances are to prevent buckling of plates and to avoid opening of gaps at plate edges where crevice corrosion might initiate. (See also GN 1.07 for splices in weather resistant steel.)
- Consider access for bolt tightening, noting possible problems at web/flange corners, so that all bolts can be placed, properly assembled and tightened fully and safely using standard tools. ((Ref 4 gives minimum distances of 60 mm for M24, 70 mm for M30 bolts, see Figure 2; add 45 mm and 50 mm for a washer, nut and protruding thread).

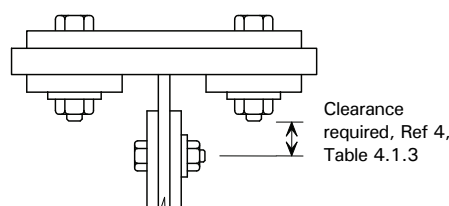
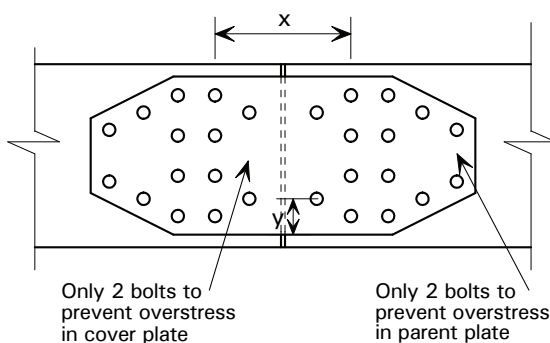

Figure 2 Access at web/flange corners

- Bolts are usually tightened by rotating the nut, but the bolt head can be turned, if an extra washer is used under the head.
  - Standardize bolt sizes (it is preferable to use M24 throughout the structure rather than M24 for main connections and limited number of M20 bolts for bracings).
  - Do not use adjacent bolt sizes (one serial size up or down) on one structure (or even on one site).
  - Avoid end plate connections if possible (less tolerance, increased prying forces).
  - Slotted holes should in general be avoided, but they do have their uses, for example where a larger tolerance is required for erection.
  - Countersunk preloaded bolts should in general be avoided, but they can be of use, for example, for attaching bearing plates and in the Network Rail standard box girder bridge (where the connections between deck plates are bolted using countersunk preloaded bolts to give a flush surface suitable for waterproofing).
  - Tightening from above (i.e. bolt heads down) gives easier access and gives better appearance on the soffit.
  - Overstresses in parent and cover plates can be avoided by reducing the number of bolts in the cross-section by use of staggered pitch at highly stressed areas, (see Figure 3).
  - When plates of different nominal thickness are connected, packs should be specified
- In proportioning cover plates, the designer should consider how they are to be handled and assembled - heavy covers can be split into more than one component, provided the usual rules on edge distances, etc. and any design implications regarding eccentricity are observed.
  - Thick cover plates can exceptionally be replaced by two plates of half the thickness to make them more easily handled and easier to draw together during bolt tightening.

### References

1. Owens & Cheal, Structural steelwork connections, Butterworths, 1989.
2. EN 14399 High-trength structural bolting assemblies for preloading (in 10 Parts)
3. Hayward A & Weare F, Steel Detailers' Manual, Second Edition (revised by Oakhill) Blackwell Science, 2002.
4. CIRIA Technical Note 98.



**Figure 3** *Layout of bolts in a flange splice*

Note:

$$X < 14t \text{ or } 200$$

$$Y < 40 + 4t$$

where  $t$  = cover plate thickness



## Welds – how to specify

No. 2.07

**Scope**

This note gives general advice on the way in which to specify welds in contract documents and provides suggestions for further reading. It is based on the assumption that all welds are arc welds.

**Terminology**

There are a number of terms in this Note that are used with specific meanings. Where these terms are first used in the Note they are underlined. The most useful standard giving long-accepted definitions is BS 499-1:2009, *Welding terms and symbols: Glossary for welding, brazing and thermal cutting*. It is worth studying to avoid misunderstandings about the terminology used in this Guidance Note. This standard has been updated to substantially align with European and international lists of terms and definitions. There are subtle differences so care is necessary when they are invoked or cross referenced in contract drawings or specifications.

**General**

Guidance Notes GN 2.01 to 2.05 give advice about detailing of steelwork. They give guidance on how a bridge girder is assembled (*i.e.* how it is joined together) and give advice on where to put splices in plates, stiffeners, fittings and attachments. The prepared pieces of plate and section are brought together to be connected by (welded) joints.

These joints fall into seven defined types of joints: butt, T, cruciform (a double T), lap, plug (a form of lap), corner and edge.

Most types of joint, including corner joint, can be made by one of two main types of weld: butt or fillet (or combinations of both). Where two plates lie flat together, with their edges aligned, they can be joined by a kind of butt, defined as an edge weld. Plug welds or fusion spot welds are used to make some lap joints, although they are very seldom used in bridgework.

A butt weld is most commonly used in a butt joint, to join two plates which are co-planar, to make one plate the continuous and wholly integral extension of the other. A fillet weld is used around a lap joint and where one

plate meets another at or about a right angle (a corner or T joint). Sometimes, however, because of design requirements, corner, T and cruciform joints are required to be made with butt welds.

The type of weld will depend most on its function. In the simplest terms, a butt weld is specified when the joint has to transfer the whole of the design force from one side of the joint to the other side, and/or when there is a requirement for a joint of high fatigue classification. Where there is no need to transfer the full force, the connection can be made with fillet welds, by butt welds of partial penetration or with a compound of butt and fillet welds. Such joints have an inherently lower fatigue classification than properly executed butt welds and may not be acceptable in certain locations on a structure. (Refer to EN 1993-1-8 clause 4 for the design of partial penetration welds.)

**Execution - general**

A weld is a particular way of making a joint; in a number of instances there is no practical alternative to welding. A welded joint has costs in preparation, in performance and in testing and inspection. Even before commencing production work there are costs in training and qualification of welders, and in performance, testing and certification of the particular weld procedures to be used (see GN 4.02).

Of the types of weld, butts are considerably more expensive to make than fillets. Butts require particular edge preparation of the fusion faces and root face. These require accurate forming, either by thermal cutting or by machining. The two parts then have to be brought together within close tolerances of alignment in plane and in the gap between the root faces. They have to be held in that position until sufficient weld is laid to avoid significant and uncontrolled relative movement. The volume of weld metal laid is significant, often requiring several runs. The welding sequence is important: both to avoid distortion at the joint and to achieve the specified mechanical properties of the weld metal and adjacent parent metal. Finally, after the weld is completed, the requirements for, and extent of, inspection and



# Guidance Note

## No. 2.07

---

testing are considerably more for butts than fillets. The requirements for inspection invariably include sub-surface (sometimes called volumetric) non-destructive testing of the weld metal, the adjacent fusion zone and the parent metal to confirm the integrity of the joint. The extent of inspection should be specified in the project documents along with any additional requirement for the preparation and destructive testing of test pieces (test coupons) for a representative sample of similar joints. In previous standards for steel bridgework, typically 1 in 5 joints in tension zones were specified to be destructively tested. The ratio was 1 in 10 similar joints for connections that experience no tension in service.

Fillet welds, on the other hand, are usually made at the junction of the flat surface of a plate (which requires no preparation except reasonable cleanliness) and the sides/ends of another flat plate (which only needs to be prepared square and straight). The requirement for reasonably close contact between the parts to be joined (the gap) is a positive advantage. The gap cannot be too small and sufficient contact is usually achievable by pressing together the two elements, which is necessary anyway to locate the attachment in the correct place. The control of the welding sequence is usually less of a problem (many fillets can be laid in one run) but it is sometimes necessary to balance the welding on each side of a joint to avoid distortion (rotation) of the attachment. Finally, except for large fillet welds (more than 12 mm leg length), the only inspection that can be performed is visual (although this does include checking the weld size) and non-destructive testing for surface breaking imperfections. Even with large fillet welds, where sub-surface, non-destructive, inspection is required, the results need very careful evaluation by an experienced welding engineer to avoid unnecessary rejection because of spurious responses from the root and toes.

### Design

The application standard for the design of steel bridges is EN 1993: *Eurocode 3: Design of steel structures*. Part 1-1 covers general rules; Part 1-5 deals with plated structures;

Part 1-8 deals with the design of joints; Part 1-9 deals with fatigue and Part 1-10 deals with material toughness and through-thickness properties. These Parts give guidance, among other things, as to where different types of weld may and may not be used.

### Execution - specific

It is the designer's responsibility to determine the type of joint and the type of weld, the extent of penetration if a partial penetration butt-weld is permitted, and the size if a fillet, at each location in the assembly. However, the designer does not know how the fabricator will choose to perform the work: the sequence of assembly, the order and orientation of welding and the particular welding process(es)/ welding sequence(s) that will be employed. These matters are within the fabricator's competence and experience, to enable him to perform the work, achieving all the specified requirements, in the most economical manner of his choice. These choices involve the exact shape of weld preparation, root face, gap, included angle, and are usually different for the same type of weld when it is performed in a different way and/or with a different process.

EN ISO 9692 is published in two parts and recommends weld preparations for manual welding processes in Part 1 and for submerged arc welding in Part 2. Butt and fillet weld joint preparations in various configurations are tabulated and shown in some detail with an illustration and with fully dimensioned cross-sections for each referenced (numbered) weld. However, the Introduction does make it clear that the requirements given in the Standard have been compiled on the basis of experience, and contain dimensions for types of weld preparation that are generally found to provide suitable welding conditions. It recognises that the extended field of application makes it necessary to give a range of dimensions, representing design limits as stated above, and that these are not tolerances for manufacturing purposes. Hence, the examples given cannot be regarded as the only solution for the selection of a joint type.

**Welds - how to specify**

*Designer:* limit specification to the provision of information on the location, dimensions and types of all welded connections. This information should be put on the contract drawings in accordance with EN 22553. For butt welds specify the degree of penetration and, if partial, specify the minimum design throat thickness rather than giving a percentage. If there is a particular concern about fatigue strength, specify particular requirements for the surface finish of the weld profile. Any welded joints requiring specific welder approval and/or pre-production welding trials should be identified in the contract documentation, on the drawings and in the project specification: see also GN 4.02.

*Fabricator:* provide information on the dimensions and details of the weld preparations that are intended to be used. Where no application standard is invoked by the project specification these should be in accordance with the examples given in EN ISO 9692. (The designer should check this.) If the proposals are not in accordance with the recommendations of the standard, the fabricator should be able to provide acceptable reasons to the designer for going outside the ranges, but may still be required to demonstrate acceptable performance by carrying out appropriate tests. See GN 4.02.

*Both designer and fabricator:* use a consistent system of welding terms and symbols, for example those given in BS 499-1 and EN 22553.

**Other considerations**

This note deals with the specification of welds, and does not cover rectifying defects that arise during the execution of the welding. In effect, the act of specification assumes that the weld will be executed without significant departure from the requirements with regard to size, shape, penetration (or otherwise), surface finish, reinforcement, etc. Clearly, however, in a complete fabrication there will be departures from intent during execution of the work. EN ISO 5817 gives guidance on quality levels for imperfections. However, Guidance Note 6.01 has been prepared to provide additional advice on the subject and should be taken into consid-

eration by the designer when setting acceptance criteria for weld imperfections which are different or additional to those in the application standards. The designer should also consider the relevant parts of the Model Project Specification (P382).

**Reference standards**

BS 499-1: 2009, Welding terms and symbols. Glossary for welding brazing and thermal cutting.

EN 1993, Eurocode 3: Design of steel structures -

EN ISO 5817: 1992, Arc-welded joints in steel. Guidance on quality levels for imperfections.

EN 22553: 1995, Welded, brazed and soldered joints: Symbolic representation on drawings.

EN ISO 9692: Welding and allied processes- Recommendations for joint preparation.

Part 1: Manual metal-arc welding, gas-shielded metal-arc welding, gas welding, TIG welding and beam welding of steels.

Part 2: Submerged arc welding of steels.

**Other references**

Steel Bridge Group: Model Project Specification for the execution of steelwork in bridges (P382), SCI, 2009.

For those who are interested in actually designing welds the following is a useful simple guide:

A guide to designing welds, Hicks J, Abington Publishing, 1989.



## Attachment of bearings

No. 2.08

**Scope**

This Guidance Note gives information about practical detailing for the attachment of bearings to plate girder and box girder bridges. For advice on bearing selection, see GN 3.03.

**General**

Bearings for steel girder bridges are of many types, such as knuckle bearings, sliding bearings, elastomeric pot bearings or laminated bearings. They can be proprietary products or purpose-made (the latter are usually all-steel bearings, such as knuckle bearings). The design of bearings should be in accordance with EN 1337 (Ref 1) but it does not cover the attachment of the bearings to the structure. This Note describes attachment details that are commonly used, and explains the design principles that are normally applied.

**Form of attachment**

It is now a general requirement that bridge bearings should be designed to be replaceable. (The requirement is reflected in advice in the draft PD 6703, Ref 2.) This requirement may be more relevant to those bearings which have elastomeric elements (the elastomer has a finite life), but it is a reasonable precaution in most cases.

The consequence of this requirement is almost always that the bearings are bolted in place, rather than welded. Typically a four-bolt arrangement is provided on each of the upper and lower elements. The bearing is bolted to the girder flange at the top and to holding down bolts set in reinforced concrete at the bottom.

For several practical reasons, a 'bearing plate' is usually provided between the bottom flange and the upper element of the bearing. In most cases with parallel-flanged girders of highway bridges the girder soffit is not horizontal (because the roadway is on a gradient or a vertical curve), yet the top surface of the upper bearing plate almost always needs to be set nominally horizontal (to avoid horizontal components arising from vertical reactions). The bearing plate is therefore usually tapered (and in bridges with integral crossheads is often tapered in both directions). Tapered bearing plates are also provided on railway bridges, although the taper is normally small.

There are two ways in which the bearings are bolted to the girders - using bolts through the upper bearing element, the (tapered) bearing plate and the bottom flange, or by bolting through the upper bearing element into tapped holes. The design issues to be considered for these two methods are explained below.

**Bolting through the girder flange**

Simply bolting through all the elements is perhaps the most immediately obvious means to attach the bearing. This makes an ordinary bolted structural connection that can be designed to EN 1993-1-8 (Ref 3), provided that preloaded bolts are used. With bolts in normal clearance holes, there is no loss of effective flange area in a compression flange (see EN 1993-1-1, clause 6.2.5 (6) (Ref 4)).

Bolts are usually fixed with heads uppermost. This facilitates the installation/removal of long bolts and avoids tightening nuts onto non-square faces.

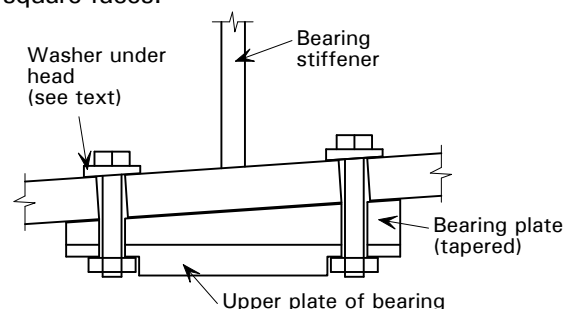

**Figure 1** Attachment by through bolting

Preloaded bolts can be used without tapered washers when the face under the head is up to about 2° from square to the bolt axis (i.e. about 3.5% gradient).

Difficulties arise, however, with thick flanges and moderately large gradient in elevation. For example, a gradient of 2.5% and a flange thickness of 60 mm reduce the effective clearance of a vertical bolt in an inclined hole by 1.5 mm. (During fabrication, it is only feasible to drill square to the plate surface, not at an angle.) This reduction in clearance would make assembly difficult and it is better from that point of view to use a slightly oversize hole. However, in that case the design resistance (to shear along the interface) is reduced by virtue of the application of a reduction factor  $k_s$  and the effective area of the com-

# Guidance Note

## No. 2.08

---

pression flange will need to be reduced for the bolt holes (see EN 1993-1-8, clause 3.9.1).

Other difficulties with this method include clashes between bolts and bearing stiffeners, and entrapment of bolts in concrete at diaphragms (see Figure 2).

### **Bolting using tapped holes**

Bearing manufacturers consider that attachment using non-preloaded bolts into tapped holes is a satisfactory method of attaching bearings, and this is by far the most popular method. The most common way of arranging this is to tap the tapered bearing plate, then weld it to the underside of the girder flange. The bolts are tightened but not tensioned to proof load (the bearing plate has a much lower material strength than the bolt). The problem with this detail is that there are no design rules (in EN 1337 or EN 1993) for the strength of the connection, nor any specific requirement for minimum engagement in the tapped hole.

Nevertheless, it is a commonly used detail, and should be satisfactory, provided that the following rules are observed:

- Use grade 8.8 bolts. The size should be sufficient for the design shear and at least M12.
- Use grade S355 steel for the bearing plate.
- Ensure that a length of thread of at least the bolt diameter is engaged in the tapped hole.

Note that welding the plate to the flange creates a detail with a fatigue category between 36 and 56, depending on thickness, as described in EN 1993-1-9, Table 8.5 (Ref 5). This may govern fatigue design at this position, especially at intermediate supports or at fixed bearings of railway bridges, where the shear forces are high. In such cases bolting through the flange may be preferable.

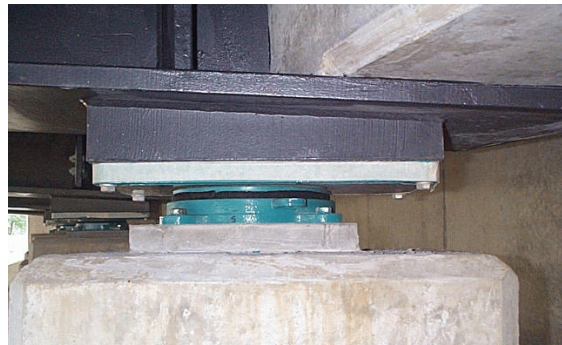

**Figure 2** Attachment by bolts in tapped holes (bearing plate is welded to flange)

### **Additional attachments**

Whilst sliding bearings are best fixed with the sliding surface facing downward so that extraneous material cannot fall onto the sliding surface, they are often mounted 'inverted' to avoid eccentric loading to the bearing stiffener. In such cases skirts should be provided (to prevent dirt, etc. reaching the upward facing sliding surface). These can usually be attached to the upper part of the bearing, rather than the girder flange. See Figure 3.



**Figure 3** Guided bearing (with skirt)

### **References**

1. EN 1337 Structural Bearings, Parts 1 to 11.
2. PD 6703 Structural bearings. Guidance on the use of structural bearings (due to be published in 2009).
3. EN 1993-1-8:2005, Eurocode 3 Design of steel structures. Design of joints.
4. EN 1993-1-1:2005, Eurocode 3 Design of steel structures. General rules and rules for buildings
5. EN 1993-1-9:2005, Eurocode 3 Design of steel structures. Fatigue

## Alignment of bearings

No. 2.09

**Scope**

This Guidance Note gives advice on making clear the requirements for the alignment of bearings.

**Background**

Bearings are normally attached to the superstructure and to the substructure using bolted connections. The position and alignment of the bolted connection to the superstructure and the foundation or holding down bolts to the substructure need to be clearly defined. In EN 1337-1, clause 7.3.2 requires that "In addition, all bearings other than elastomeric bearings shall be marked with ... the direction of installation."

If information is not provided in a clear and consistent manner as part of the contract documentation at an early stage, there is a risk of delay in determining the attachment details at the fabrication stage and to confusion in setting out the fixings in the substructure (possibly leading to re-work at a late stage).

This note is intended to draw attention to the need to convey the information at an early stage and to show how the information may be presented.

**Showing orientation on the drawings**

The direction of installation could be shown in the layout diagram on the design drawings by half-shading the symbols used for the bearings, as shown in Figure 1.

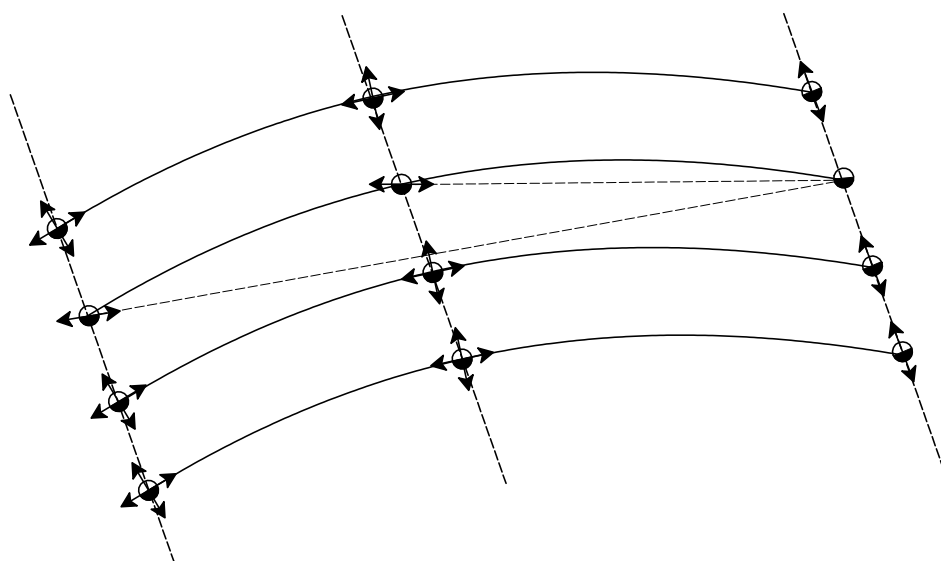

**Figure 1** *Indicating bearing alignment on drawings*

In this example the guided pot bearings are to be aligned in order to achieve movements (due to expansion and contraction) in a radial direction from the fixed bearing at the right hand end. Other articulation arrangements could have been chosen (see GN1.04 for guidance on selection of articulation arrangements).

**Showing orientation on bearing drawings**

The same orientation symbols could be shown on the bearing manufacturer's drawing. This will facilitate the determination of the details of the tapered bearing plates.

The symbols could also be marked on the bearing itself but that would not be essential.

An example of the marking system using the modified symbol for pot bearings is shown in Figure 2 and Figure 3.

# Guidance Note

## No. 2.09

---

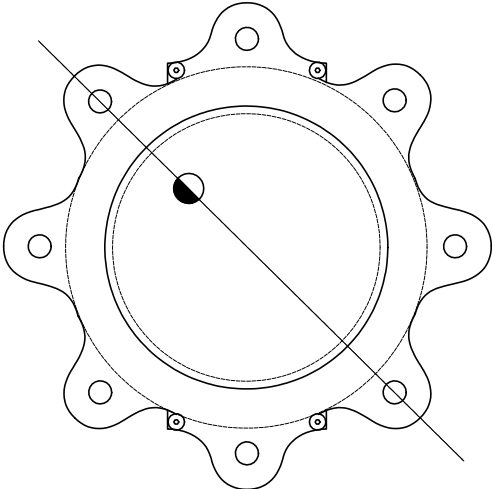

**Figure 2** *Example of marking a restraint bearing*

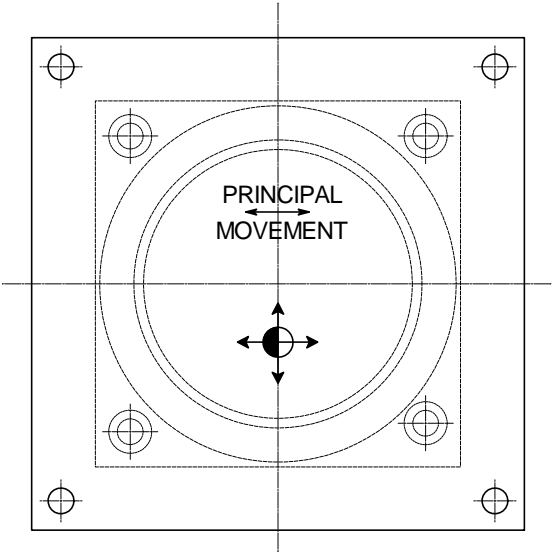

**Figure 3** *Example of marking a multi-directional sliding bearing*

### References

- 1. EN 1337-1:2000, Structural bearings

## Steel deck plate for footbridges

No. 2.10

### Scope

The purpose of this note is to give guidance on the minimum steel deck plate thickness to be used for a footbridge and the span of the deck plate panels between stiffeners and other supporting members. The strength of the deck plate is not discussed. Other aspects of steel footbridge design are given in other References 1 and 2.

The Note records a consensus view of what thickness of deck plate is required, based on data collected from a number of bridges and discussions with their designers.

### Form of construction

A steel deck plate for a footbridge is usually a welded integral part of the bridge deck and it can be quite thin (typically 6 mm or 8 mm). It is usually supported at the edges by the main structural members and transversely by crossbeams and stiffeners, sometimes in conjunction with longitudinal stiffening to limit the span of the plate.

The plate is usually surfaced with a 3 mm thickness of an extended tar epoxy, with a grit finish. The surfacing is laid directly onto blast cleaned bare steel and it acts as corrosion protection, waterproofing and wearing surface, all in one. There are widely used proprietary products for this surfacing which are hard wearing, economic and light.

However, the thinness of the surfacing leads to two consequences:

- The surfacing does not contribute significantly to the out-of-plane stiffness of the plate.
- The surfacing is too thin to provide a regulating course to correct any noticeable dishing of the deck plate due to weld distortion.

### Design basis

A deck plate can be thick enough to carry the loads applied and yet it can feel too flexible under foot. The problems that can occur when the plate is too thin are:-

- A feeling of flimsiness.
- Ponding water
- Visible dishing.

Visible dishing and ponding in areas where the dishing is less noticeable but still present is due to distortions caused by weld shrinkage.

Of the above three aspects, ponding of water is most often quoted as provoking adverse comment from clients. The problem is aggravated when ponded water freezes.

The designers of proprietary footbridges generally use 6 mm deck plates, typically supported at 500 mm centres, although spans of up to 700 mm are not unusual. These arrangements are generally found to be satisfactory in relation to the three potential problems mentioned above.

A review of recent 'bespoke' footbridges found that most designers had chosen 8 mm deck plates, typically spanning 700 mm to 800 mm. These arrangements were also generally considered satisfactory.

### Guidelines and design rules.

This topic has not been covered by design standards in the past. In EN 1993-2 it is only covered for footbridges which are also subject to loads from maintenance vehicles, although it is not clear what maintenance vehicle has been allowed for. The UK NA to EN 1993-2 also covers footbridges without maintenance vehicles. It gives three requirements.

- Plate thickness  $\geq 6$ mm.
- Span/plate thickness  $\leq 92$
- Span  $\leq 900$ mm.

The first two are a redrafting of the guidelines given in earlier editions of this note. The span limit is in line with the span limits for other loads given in EN 1993-2:2006.

To the above requirements can be added the following additional guidelines:

- With good drainage falls (e.g. 4% or more), slightly longer spans than the above will also be satisfactory
- Weld sizes should be kept to a minimum to limit distortion (leg length not more than 2/3 the plate thickness)



# Guidance Note

## No. 2.10

---

- Intermittent welding should not be considered (except inside box girders) because it is more prone to corrosion

### References

For further guidance on the design of steel footbridges, see:

1. The design of steel footbridges, Corus Construction & Industrial, 2005.
2. Bridged in Steel 5, Gablecross cycleway and footbridge, Swindon, British Steel, 1987.
3. EN 1993-2:2006, Eurocode 3, Design of steel structures. Steel bridges.

**Scope**

This Guidance Note gives advice on the shear connection between the steel girder and concrete slab of a typical steel composite bridge. Various means of providing the shear connection are mentioned, but this note focuses on the use of shear studs, which are predominantly used. EN 1994-2 only gives specific design rules for shear studs, but other connectors may be designed in accordance with the other Eurocode rules. The National Annex to BS EN 1994-2 gives some design rules for block and hoop connectors.

This brief note is intended to outline the design issues to consider, guide the reader to the appropriate code clauses, and discuss some fabrication aspects.

**General**

Shear connectors are required on the top flange of steel composite bridge girders to provide the necessary shear transfer between the steel girder and composite slab that is required for composite action. The most widely used form of shear connector is the headed stud, or shear stud. Refer to Figure 1.

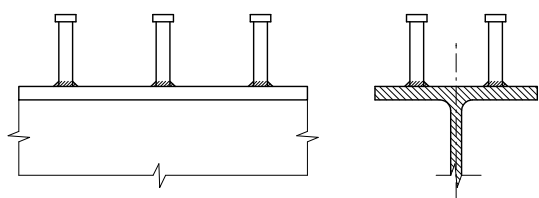

**Figure 1** Typical shear stud connectors

The advantages of shear studs over other forms of connectors are that the welding process is quick and simple, they provide little obstruction to the slab reinforcement, permit more satisfactory compaction of the concrete around the connectors, and provide equal shear strength in all directions.

Other forms of shear connector, which are sometimes used include block and hoop, and channel connectors, as illustrated in Figure 2. These types of connector are typically used where large shear transfers are required, as an alternative to closely spaced shear studs.

Shear connectors must be designed to provide static strength, and for fatigue loading. The

shear flow varies along the length of a girder, being highest near the supports, and it is customary to vary the number and spacing of connectors to provide just sufficient shear resistance for economy. Hence, shear flows should be calculated at supports, at midspan, and at least one position in between, i.e. quarter points, in order to plot a shear flow profile along a girder. There may also be a need to calculate shear flow at a significant change in beam section.

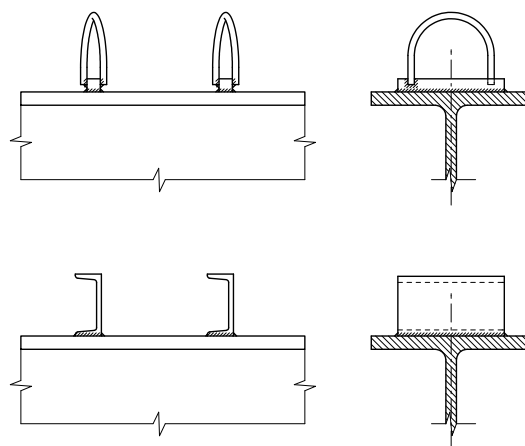

**Figure 2** Block and hoop, and channel shear connectors

**Static design**

The shear connection needs to be verified at ULS and at SLS. The requirement at SLS is given in clause 6.8.1(3) of EN 1994-2 as a limit to the maximum force under the characteristic combination of actions. The SLS limit will usually only be critical for long span bridges with a high dead load component.

For Class 1 or 2 sections, because the bending resistance at ULS is calculated in terms of a plastic stress distribution, shear flow in zones where the slab is in compression must also be calculated using a plastic stress distribution. In zones where the slab is in tension, the shear flow may be calculated on the basis of elastic section properties and assuming the concrete to be uncracked. The unconservative neglect of plasticity is offset by the conservatism of ignoring cracking.

The design resistance of shear connectors is given by clause 6.6.3.1 of EN 1994-2-2. For elastically designed zones, the spacing of the connectors may provide a 'stepped' resistance, subject to the provision of sufficient

# Guidance Note

## No. 2.11

total resistance over each length. The maximum calculated shear flow within the length of any such group must not be more than 10% in excess of its design resistance per unit length. For plastically designed zones, this provision does not apply as the connectors must be proportioned to resist the average force in the inelastic zone.

### Fatigue design

Verification of the connectors for fatigue is carried out for an equivalent constant range of shear stress given by clause 6.8.6.2 of EN 1994-2, based on the stress range due to the fatigue load model 3 (FLM3) and damage equivalence factors. The fatigue strength curve is that for detail category 90. Adequacy is assessed to clause 6.8.7.2; for connectors on tension flanges interaction with the tensile stress in the flange needs to be considered but does not normally govern, since worst shear and worst tension rarely coexist. Fatigue may govern the spacing of connectors in midspan regions of longitudinal members but does not often govern near supports.

### Transverse reinforcement

Transverse reinforcement is required in the slab to provide shear resistance. This is needed both to prevent splitting of the concrete adjacent to the stud and to allow load to spread out across the width of the slab. Refer to EN 1994-2, clauses 6.6.5 and 6.6.6. An interaction between steel requirements for bending in the slab and longitudinal shear has to be considered. Particular care is needed for ladder deck construction where the transverse reinforcement required for bending is usually smaller, and may not be sufficient on its own to transfer high shear flows. Additionally, cross girders in ladder decks may have their transverse reinforcement in tension from the global behaviour of the main beams. In such cases, the effect of this tension must be fully added to that from longitudinal shear – see Hendy and Johnson (Ref 2) or P356 (Ref 3).

### Practical aspects

Standard sizes for shear studs, which are readily available from suppliers and typically used in steel composite bridge decks, are indicated in Table 1. Stud heights outside

this range are available, and stud manufacturers should be contacted to check availability. Although studs over 19 mm diameter are available, they are not preferred by fabricators, as a higher level of defective welds can be expected, due to the higher currents and magnetic field effects.

**Table 1** Standard sizes of Shear Studs

Stud height (mm)	Stud diameter (mm)			
	16	19	22	25
125	Available but rarely used in bridges	Occasionally used in bridges	Commonly used in bridges	Commonly used in bridges
150	Available but rarely used in bridges	Commonly used in bridges	Commonly used in bridges	Commonly used in bridges
175	Available but rarely used in bridges	Commonly used in bridges	Commonly used in bridges	Commonly used in bridges
200	Available but rarely used in bridges	Commonly used in bridges	Commonly used in bridges	Commonly used in bridges
250	Available but rarely used in bridges	Available but rarely used in bridges	Commonly used in bridges	Commonly used in bridges
	Commonly used in bridges			
	Occasionally used in bridges			
	Available but rarely used in bridges			

EN 1090-2 refers to EN ISO 13918 for the requirements for stud shear connectors. In that Standard, two grades of carbon steel stud are given, SD1 and SD2. Grade SD1 has the higher strength (minimum yield strength of 350 N/mm<sup>2</sup>, and a minimum tensile strength of 450 N/mm<sup>2</sup> but these values are less than those for studs previously supplied to BS 5400-5. It is suggested that SD1 studs be specified but with minimum yield strength of 385 N/mm<sup>2</sup>, and minimum tensile strength of 495 N/mm<sup>2</sup>, which is the strength that has been available in the UK for very many years.

Shear studs are generally attached to the top flanges of girders using a stud welding gun. The stud is held in the welding gun and an arc is struck between the stud and the flange plate. The arc melts a portion of both the stud and the plate in a set time. The gun then automatically plunges the stud into the molten pool of metal and holds it there until the weld solidifies. The molten metal is held in place by a ceramic ferrule, which also serves to shield the arc. Figure 3 illustrates a stud with the ceramic ferrule still in place.

Testing shows that the weld collar so formed is very important in transmitting shear. The resistances for shear studs in EN 1994-2 therefore only apply to studs attached in this way. Studs attached by friction welding, for

example, cannot be designed using the EN 1994-2 rules for static or fatigue strength.

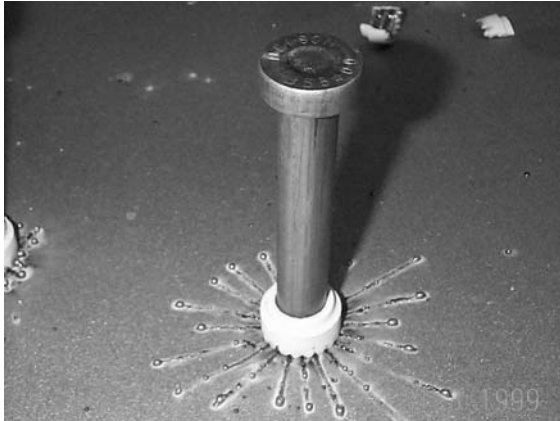

**Figure 3** Typical shear stud after welding

Shear studs should be welded in accordance with the manufacturer's instructions, including preheating where necessary. The studs, and plate to which they are welded, must be dry and clean otherwise the quality of the weld will be adversely affected, and welding should not be carried out when the temperature is below 0°C.

The equipment required for stud welding is specialist but readily portable, so although the majority of studs are welded in the shop, they could be welded on site if required, although it is unlikely to be economic for small numbers of studs: fillet welding is more practical for small numbers and such welds are structurally satisfactory. Where studs are manually welded on site, there should be a defined weld procedure; it is likely that preheat will be needed because the weld is small in extent.

#### Spacing of shear connectors

The minimum distance between the edge of a shear connector and the edge of a flange plate is specified as 25 mm in EN 1994-2, clause 6.6.5.6(2). However, other issues need to be considered as follows.

Many steel composite decks are constructed using permanent formwork, usually either precast concrete 'Omnia' planks or GRP panels. Allowance needs to be made for the bearing or seating lengths required, which are typically 50 mm, and also tolerances on the girder spacing. The extent of the painting

envelope is also important, as shear connectors should ideally not be painted. The SCI Model Project Specification document P382 (Ref 3) recommends a 25 mm return into the concrete/steelwork contact area and a 25 mm tolerance on girder seating and formwork length. This leads to a recommended minimum edge distances of 100 mm where permanent formwork is used. In other cases, a minimum of 50 mm will generally be sufficient.

The minimum spacing between the centrelines of shear studs is governed by access requirements for the stud welding gun. A minimum spacing of between 60 mm and 70 mm is possible, depending on the size of the studs, but a minimum of 100 mm is preferred by fabricators.

The maximum longitudinal spacing is defined in EN 1994-2, clause 6.6.5.5(3), and is the lower of the following:

- 800 mm
- 4 x concrete slab thickness
- A lower value if needed to restrain local buckling of the flange such that it achieves a classification of Class 1 or 2

There are also further limits in EN 1994-2 Table 9.1 on the spacing of studs on composite plates, such as in composite box girders, where it is necessary for the studs and concrete to restrain the flange.

In determining the actual spacing of shear studs along the length of the steel girder it is usual to adopt a spacing equal to the transverse deck reinforcement spacing, or multiples thereof. This facilitates the easy fixing of the deck reinforcement.

Note that in steel box girders with composite flanges, there will be a concentration of shear transference local to the box webs. Shear studs will need to be arranged to suit this, resulting in a higher density of connectors above the webs - see EN 1994-2 clause 9.4.

#### Size of shear connectors

Clearly, the design for shear transfer will have a bearing on the size of the shear stud. However, EN 1994-2 defines other criteria to consider:

# Guidance Note

## No. 2.11

---

Clause 6.6.5.7 requires that the diameter of the shear stud should not exceed one and a half times the plate thickness, if the plate is subjected to tensile stress and fatigue loading, and two and a half times the plate thickness in other cases.

Clause 6.6.5.1 requires that the underside of the head of the stud should project at least 30 mm above the bottom transverse reinforcement. This will usually govern the height of the stud. Additional height should be considered on shear connectors, particularly on decks where there is severe crossfall. This provides additional tolerance in construction, and assists in achieving the required projection of the head above the transverse reinforcement. There is an additional requirement in clause 6.6.5.7 that the height should not be less than three times the stud diameter but this seldom governs.

The welding current needed to weld the studs increases rapidly as the stud diameter increases. For 25 mm studs, the heat input and rapid cooling of the weld metal mean that it can be very difficult to find a weld procedure that will keep hardness in the HAZ within specification. Equipment to weld 25 mm studs is not suitable for site work.

### Testing

On visual inspection, the weld to a stud connector should form a complete collar around the shank, be free from cracks and excessive splashes of weld material, and have a 'steel-blue' appearance.

The model project specification (Ref 4) includes inspection and testing requirements that have been taken from BS 5400-6, in the absence of comparable requirements in EN 1090-2.

There are two tests to check the fixing of shear studs: the ring test and the bend test.

The ring test simply involves striking the side of the head of the stud with a 2 kg hammer. A ringing tone after striking indicates good fusion, whereas a dull tone indicates a lack of fusion. All studs should be checked in this way by the welder or the welder's mate.

The bend test requires the head of a stud to be displaced laterally by approximately a quarter

of its height using a 6 kg hammer. The weld should then be checked for signs of cracking or lack of fusion. Figure 4 illustrates a typical stud after a bend test. It is important to note that studs should not be bent back as this is likely to damage the weld. The testing rate should be specified by the designer and is usually 1 stud in 50. However, any studs which fail the ring test, or are suspect on visual inspection should also be checked in this way.

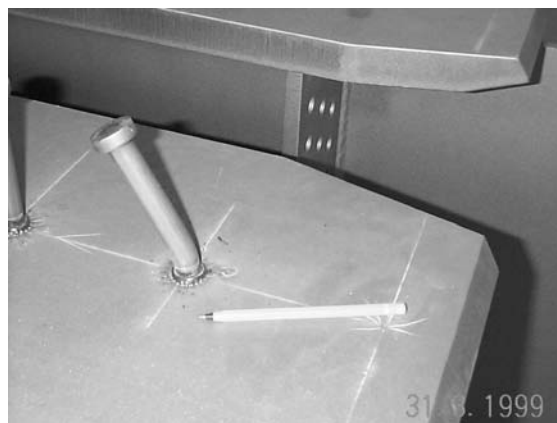

**Figure 4** *Shear stud after bend test*

### References and further reading

1. EN 1994-2:2005, Eurocode 4: Part 2, Steel and concrete composite bridges.  
*Plus the UK National Annex:*  
NA to BS EN 1994-2:2005, BSI, 2007
2. Hendy C R and Johnson, R P, Designers' Guide to EN 1994-2, Thomas Telford, 2006
3. Design of composite highway bridges (P356), SCI, 2009
4. Steel Bridge Group: Model project specification for the execution of steelwork in bridge structures (P382), SCI, 2009

**Scope**

This Guidance Note gives information on the key physical and mechanical properties of most structural steels commonly used in bridge works. The information should be sufficient to enable a designer to select the appropriate steel grades to achieve the required design characteristics.

Correct specification of the steel material will ensure that the structural performance presumed in the design will be achieved in the completed bridge structure.

Comments on the many and differing grades used in the past are generally outside the scope of this Note.

**Key physical/mechanical properties of steels**

Steel derives its mechanical properties from a combination of chemical composition, heat treatment and mechanical working. The bridge designer cannot reasonably be expected to understand all the detailed implications of the differences between the various grades, but an understanding of the importance of each of the key properties and the means of achieving them will be of benefit.

The following properties are of particular importance to the bridge designer:

- yield strength
- modulus of elasticity
- coefficient of thermal expansion
- ductility (in plane and through thickness)
- notch toughness (impact strength)
- weldability
- corrosion resistance

The designer has scope to select some of these properties; others (such as modulus) are implicit in the use of structural steel.

**European steel specifications**

Generally, all new steel for structural purposes should be 'hot-rolled steel' manufactured to a CEN European Standard (EN). These standards are issued in the UK through BSI, and consequently bear the EN designation. In the CEN designation system (see EN 10027 and ECIS IC10), all structural steels have the prefix 'S'.

The following standards are relevant to bridge steelwork:

EN 10025, Parts 1 to 6  
EN 10210

A summary of the grades available in these standards is given in Table 1.

The use of cold formed hollow sections is also covered by Eurocode 3 but these sections are rarely used (see further comment about notch toughness, below).

**Yield strength**

The yield strength is probably the most significant property that the designer will need to use or specify. The achievement of a suitable strength whilst maintaining other properties has been the driving force behind the development of modern steel-making and rolling processes.

In the European Standards for structural steels, the primary designation relates to the yield strength, e.g. S355 steel is a structural steel with a nominal yield strength of 355 N/mm<sup>2</sup>. The number quoted in the designation is the value of yield strength for material up to 16 mm thick. Yield strength reduces with increasing plate or section thickness; this is taken into account in the design standards.

The strength grades covered by the above EN standards include the following:

S235, S275, S355, S420 and S460.

Yield strengths above 460 N/mm<sup>2</sup> are available in EN 10025-6. The use of grades above S460, up to S700, is covered by EN 1993-1-12. (Note that the limitation in the UK NA that the ratio of specified ultimate/yield strengths is at least 1.10 is met by these grades of steel to EN 10025-6.)

Steels of 355 N/mm<sup>2</sup> yield strength are predominantly used in bridgeworks applications in the UK because the cost-to-strength ratio of this material is lower than for other grades. However, some of the higher strength grades offer other advantages and may be seen more frequently in the future. (But note that the use of higher strength steels confers no benefits in applications which are fatigue critical or in which instability of very slender members is the overriding design consideration.)

# Guidance Note

## No. 3.01

---

The strength of the steel is achieved by including alloying elements (notably carbon and manganese) and by the production process. The strength depends on the grain structure of the steel alloy and this depends on both the cooling rate and the working of the steel.

There are a number of production processes for hot rolled steels and it is worth explaining briefly what the main ones are.

### *Normalized steel*

When steel is hot-rolled, the temperature of the steel steadily drops (from about 1200°C) during rolling. However, improved properties can be achieved if the steel is subsequently 'normalized' by heating it to about 900°C and allowing it to cool naturally (in still air).

### *Normalized rolled steel*

Similar properties to those of normalized steel can be achieved in a single process if the temperature during rolling is controlled so that all rolling is carried out at or above about 900°C, provided the steel then cools naturally.

### *Thermomechanically rolled (TMR) steel*

In a further refinement of the rolling process, a slightly lower alloy steel (less carbon) can achieve similar properties by rolling in a carefully controlled manner, down to a finishing temperature of between about 700°C and 800°C.

### *Quenched and tempered (Q&T) steel*

Quenching is a process where the steel is heated above 900°C, which allows the formation of an austenitic grain structure. The steel is then cooled rapidly (by immersion in a bath of water, or by passing through a curtain spray). This produces a high strength steel with high hardness, but with low toughness.

Toughness is restored by tempering, heating to between 600°C and 700°C. The Q&T process can achieve much higher yield strengths, but subsequent heating, for example due to welding or prolonged heat treatment, may have an effect on the properties. Specialist advice should be sought if procedures are to be developed for welding or flame straightening of Q&T steels. Stress relieving can be carried out at 30°C below the tempering temperature (see the test certificate for that temperature), but

seek the supplier's advice on the effect of this on the properties.

### *Delivery condition*

The 'delivery condition' indicates which of the above processes is to be used and is designated by an alphabetic code. In some standards there is only the one delivery condition; in other standards there are options.

In EN 10025-2 and EN 10025-5, the delivery condition is either 'at the manufacturer's discretion' or is specified as an 'Option'. The two Options available are:

- +N Normalized and normalized rolled
- +AR As rolled

These Options are indicated by adding the code after the grade and quality (toughness) designation (see below for toughness grades), for example S355J2+N.

In each of EN 10025-3 and EN 10025-4 there is only the one delivery condition, indicated by adding N (normalized/normalized rolled) or M (thermomechanically rolled) after the strength grade.

In EN 10025-6, there is only the one delivery condition, indicated by adding Q (quenched and tempered), for example S355Q.

'Flat products' (plate and strip) can be produced by any of the above processes. 'Long products' (sections and bars) are generally supplied 'as rolled'. The as rolled condition for long products is effectively the same as normalized rolled. Long products can be supplied as 'M' steels, by agreement with the supplier.

EN 10210 covers two types of steel, non-alloy and fine grain steel. The delivery of the former is hot finished and of the latter is normalized/normalized rolled (indicated by adding N to the strength grade). Additionally, the letter H is added at the end of the designation (after the quality designation) to indicate hollow sections. EN 10219 also covers non-alloy and fine grain steels, the delivery condition is cold formed and the letter H is added at the end of the quality designation.

**Modulus of elasticity and coefficient of thermal expansion**

These properties are taken as constant for all structural steels regardless of grade or yield strength. Therefore, the designer need not consider them when selecting an appropriate steel grade. EN 1993-1-1 gives the modulus of elasticity ( $E$ ) as 210 kN/mm<sup>2</sup>, the shear modulus ( $G$ ) as 80 kN/mm<sup>2</sup>, Poisson's ratio  $\nu$  as 0.3 and the coefficient of thermal expansion as  $12 \times 10^{-6}$  per °C (although EN 1994-1-1 recommends the value of  $10 \times 10^{-6}$  per °C for effects in composite bridges other than change in length).

**Ductility**

Ductility is of paramount importance to all steels in structural applications. It is a measure of the degree to which the material can strain or elongate between the onset of yield and eventual fracture under tensile loading.

Whether it is realised or not, the designer relies on ductility for a number of aspects of design: redistribution of stress at the ultimate limit state; bolt group design; reduced risk of fatigue crack propagation; and in the fabrication process in welding, straightening, bending, etc.

Ductility tends to reduce with increasing yield strength. Fortunately, this effect is not significant enough to affect the design of the majority of bridges.

Ductility of a steel plate or rolled section is measured in relation to behaviour in the plane of the element (plate, flange or web), either in or normal to the direction of rolling, and in relation to through-thickness behaviour (i.e. perpendicular to the plane of the element). The two measurements have different significance for the designer.

*In-plane ductility*

The material standards specify minimum elongation at failure under test. Material complying with these standards usually possesses adequate in-plane ductility for the bridge designer's and the fabricator's purposes, hence no additional specification is needed.

*Through-thickness ductility*

The properties of steel perpendicular to the plane of the element are different to those in-plane. This is particularly true for ductility,

which is generally lower in the direction normal to the plane of rolling.

For several reasons, a designer should try to avoid welded joint configurations in which plate material is subjected to high tensile stresses in the through-thickness direction (see GN 3.02). Where there is such a joint carrying significant load, the specification of material with assured through-thickness properties is usually required.

Through thickness ductility may be specified as an 'option' in EN 10025, in terms of one of three 'levels' according to EN 10164. These levels are expressed in terms of the percentage reduction of area obtained during through-thickness tensile tests on small specimens of plate material. High ductility is indicated by a high percentage (e.g.  $\geq 35\%$  as the average of six test pieces per plate and  $\geq 25\%$  for any single value). See GN 3.02 for detailed advice on specifying through thickness ductility.

**Notch toughness (impact strength)**

The nature of steel material is that it always contains some imperfections, albeit of very small size. When subject to tensile stress these imperfections (similar to very small cracks) tend to open; if the steel is insufficiently tough, the 'crack' propagates rapidly, without plastic deformation, and failure may result. This is called 'brittle fracture' and is of particular concern because of the sudden nature of failure. Also, the toughness of the steel, and its ability to resist this behaviour, decreases as the temperature decreases. The toughness required, at any given temperature, increases with the thickness of the material.

A convenient measure of toughness is the Charpy V-notch impact test (hence the use of the terms 'Charpy energy' and 'notch toughness' in EN 1993-1-10). This test measures the impact energy (in Joules) required to break a small notched specimen by a single impact blow from a pendulum; the test is carried out with the specimen at a specified (low) temperature. In the material standards, tests are specified typically at  $-20^{\circ}\text{C}$  and the required minimum value is typically 27J. Other temperatures and energy values are specified for different grades.



# Guidance Note

## No. 3.01

---

The material standards designate the available toughness quality in a number of different ways.

Standards EN 10025-2 and EN 10025-5 offer a choice of four qualities, designated by appended a two letter alphanumeric code to the steel strength code, for example S355J2. The four codes are:

- JR: 27J impact energy at +20°C
- JO: 27J impact energy at 0°C
- J2: 27J impact energy at -20°C
- K2: 40J impact energy at -20°C

Quality JR is not suitable for bridges because the NA to BS EN 1993-1-10 prohibits the use of steels at temperatures more than 20°C below the test temperature.

EN 10210 also offers qualities JO and J2 for non-alloy hollow sections.

Standards EN 10025-3 and EN 10025-4 each offer only two qualities, one being differentiated by the addition of 'L' after the strength grade and delivery condition. The two grades are:

- 40J impact energy at -20°C
- L 27J impact energy at -50°C

EN 10210 also offers these two qualities for fine grained steel hollow sections.

Standard EN 10025-6 offers three qualities, two designated by the addition of a code:

- 30J impact energy at -20°C
- L 30J impact energy at -40°C
- L1 30J impact energy at -60°C

The designer is thus able to select and specify an appropriate toughness/ impact strength for his structure. He can take advantage of a lesser need for toughness during construction, if it is certain that the component will be subject to only moderate tensile stresses or to less severe minimum temperatures, but it is wise not to rely on this unless absolutely necessary. It is imperative that the rules be rigorously observed for normal service conditions.

For ease of application, toughness requirements can be presented in the form of tables of limiting thickness: for a given minimum service temperature and maximum tensile stress in an element of a particular grade of

steel. Such tables give the designer a maximum thickness of component that will have sufficient toughness. Explicit relationships between temperature and toughness are also provided. (It may be noted that the requirements are less onerous in building design as the minimum service temperatures are generally higher.) Tables are given in EN 1993-1-10 but the NA to BS EN 1993-1-10 refers to PD 6695-1-10 for simplified tables that avoid the detailed evaluation of 'reference temperature' required for the use of the EN 1993-1-10 tables.

In the UK most designers are led to the use of toughness grades J2 or K2 (or the lower grades of N and M steels) in recognition that the minimum bridge service temperature of composite bridges in UK does not fall below -20°C. However, toughness is assured up to 20°C below the test temperature, and consequently JO steels will be satisfactory in many circumstances.

Cold formed hollow sections to EN 10219 can be supplied in qualities JO, J2, K2, N and NL (for JO it is necessary to specify the Option that toughness be verified). However, it should be noted that for rectangular hollow sections the toughness is only verified at the middle of the flat sides; the toughness is very significantly reduced in the corners by the cold forming process (the reduction in reference temperature  $\Delta T_{\varepsilon_{cf}}$  given by EN 1993-1-10, 2.3.1 can be as much as 99°C). Cold formed rectangular hollow sections are therefore unsuitable for bridges.

### **Weldability**

All structural steels are essentially weldable. However, welding involves locally heating the steel material, which subsequently cools. The cooling can be quite fast, because the material offers a large 'heat sink' and the weld (and the heat introduced) is relatively small. This can lead to hardening of the 'heat affected zone' and to reduced toughness. The greater the heat input, the less the reduction; the greater the thickness of material, the greater the reduction of toughness. Thus thick material may need to be preheated.

The susceptibility to embrittlement depends on the alloying elements, principally, but not exclusively, on the carbon content. This susceptibility can be expressed as the 'Carbon Equivalent Value' (CEV), and the standards give an expression for determining this value. Welding standards (such as EN 1011-2) will indicate what preheat, if any, is needed for a given CEV, material thickness and weld size.

EN 10025 gives limiting values for CEV that are automatically invoked when specific inspection is called for. It may be noted that fine grain steels (to Parts 3 and 4 of EN 10025)

generally have a lower value of maximum CEV than have non-alloy steels to Part 2.

### **Corrosion Resistance**

All structural steels, with the exception of steels with improved atmospheric corrosion resistance ('weather resistant steels'), have a similar resistance to corrosion. In exposed conditions they need to be protected by a coating system.

Weather resistant steels form a tightly adhering oxidised steel coating or 'patina' that inhibits further corrosion. See GN 1.07 for further advice.

### **Reference Standards**

EN 1011-2:2001, Welding. Recommendations for welding of metallic materials. Arc welding of ferritic steels.

EN 1993 Eurocode 3: Design of steel structures

EN 1993-1-1:2005, General rules and rules for buildings

EN 1993-1-10:2005, Material toughness and through-thickness properties

EN 1993-1-12:2007, Additional rules for the extension of EN 1993 up to steel grades S700

EN 1994-2:2005, Eurocode 4: General rules and rules for bridges

EN 10025: 2004, Hot rolled products of structural steels.

Part 1: 2004, General technical delivery conditions.

Part 2: 2004, Technical delivery conditions for non-alloy structural steels.

Part 3: 2004, Technical delivery conditions for normalized/normalized rolled weldable fine grain structural steels.

Part 4: 2004, Technical delivery conditions for thermomechanical rolled weldable fine grain structural steels.

Part 5: 2004, Technical delivery conditions for structural steels with improved atmospheric corrosion resistance.

Part 6: 2004, Technical delivery conditions for flat products of high yield strength structural steels in the quenched and tempered condition.

EN 10027, designation systems for steel

Part 1: 1992, Steel names, principal symbols.

EN 10210, Hot finished structural hollow sections of non-alloy and fine grain structural steels.

Part 1: 2006, Technical delivery requirements.

EN 10219, Cold formed welded structural hollow sections of non-alloy and fine grain steels.

Part 1: 2006 Technical delivery conditions

PD 6622:1998, CR 10260:1998, Designation systems for steel. Additional symbols.

PD 6695-1-10:2009, Recommendations for the design of structures to BS EN 1993-1-10

# Guidance Note

## No. 3.01

**Table 1 Summary of grades available**

EN 10025-2: Hot rolled products of non-alloy structural steels		
Designation	Impact strength t = 10, 150mm	Max CEV t = 40 -150mm
S275JO	27J @ 0°C	0.42
S275J2	27J @ -20°C	0.42
S355JO	27J @ 0°C	0.47
S355J2	27J @ -20°C	0.47
S355K2	40J @ -20°C	0.47
Grade S235 is available, but is not used for bridge work. Delivery conditions: may be specified as normalized/normalized rolled (+N) or as rolled (+AR).		

EN 10025-3: Hot rolled products in weldable fine grain structural steels: normalized/ normalized rolled steels		
Designation	Impact strength t = 10, 150mm	Max CEV t = 63 – 100mm
S275N	40J @ -20°C	0.40
S275NL	27J @ -50°C	0.40
S355N	40J @ -20°C	0.45
S355NL	27J @ -50°C	0.45
S420N	40J @ -20°C	0.50
S420NL	27J @ -50°C	0.50
S460N	40J @ -20°C	0.54
S460NL	27J @ -50°C	0.54
Delivery conditions: normalized/normalized rolled		

EN 10025-4: Hot rolled products in weldable fine grain structural steels: thermomechanical rolled steels		
Designation	Impact strength t = 10, 150mm	Max CEV t = 63 – 150mm
S275M	40J @ -20°C	0.38
S275ML	27J @ -50°C	0.38
S355M	40J @ -20°C	0.45
S355ML	27J @ -50°C	0.45
S420M	40J @ -20°C	0.47
S420ML	27J @ -50°C	0.47
S460M	40J @ -20°C	0.48
S460ML	27J @ -50°C	0.48
Delivery conditions: thermomechanical rolled		

EN 10025-5: Structural steels with improved atmospheric corrosion resistance		
Designation	Impact strength	Max CEV
S355J0W	27J @ 0°C	0.52
S355J2W	27J @ -20°C	0.52
S355K2W	40J @ -20°C	0.52
Grade S235 is available, but is not used for bridge work, nor is subgrade P of S355. Delivery conditions: may be specified as normalized/normalized rolled (+N) or as rolled (+AR).		

EN 10025-6: Flat products in the quenched and tempered condition		
Designation	Impact strength	Max CEV t = 50 -100mm
S460Q	30J @ -20°C	0.48
S460QL	30J @ -40°C	0.48
S460QL1	30J @ -60°C	0.48
S690	30J @ -20°C	0.77
S690QL	30J @ -40°C	0.77
S690QL1	30J @ -60°C	0.77
Other strength grades are available but S460 and S690 are most commonly used. Grades up to S700 are covered by EN 1993-1-12. Delivery conditions: quenched and tempered		

EN 10210: Hot finished structural hollow sections of non-alloy and fine grain structural steels		
Designation	Impact strength	Max CEV* t = 16 – 40mm
Non-alloy		
S275JOH	27J @ 0°C	0.43
S275J2H	27J @ -20°C	0.43
S355JOH	27J @ 0°C	0.47
S355J2H	27J @ -20°C	0.47
Fine grain		
S275NH	40J @ -20°C	0.40
S275NLH	27J @ -50°C	0.40
S355NH	40J @ -20°C	0.45
S355NLH	27J @ -50°C	0.45
S460NH	40J @ -20°C	
S460NLH	27J @ -50°C	
Delivery conditions: JO, J2, hot finished N, normalized/normalized rolled * Max CEV values apply only if agreed at the time of order		

**Scope**

This Guidance Note gives advice on the need for steel with improved 'through thickness properties' and on the selection of an appropriate quality class where such steel is needed.

**Steel is an anisotropic material**

Steel plate and sections are produced by a process of rolling, and the mechanical properties that the material attains are influenced by the working of the metal as it cools. Sections are rolled from a compact 'bloom' (a large rectangular piece of steel) into a very long element; any inclusions and non-uniformities in the metal are essentially linear in nature. Plate is rolled from slab, but there is a degree of cross rolling as well as rolling in the longitudinal direction; any inclusions and non-uniformities are therefore essentially planar in extent and parallel to the surface of the plate. The mechanical properties of the material are therefore not the same in all directions; the material is anisotropic.

Material properties for steel sections are specified by reference to test specimens aligned longitudinally in the section. It is presumed that transverse properties (e.g. for bending of the flange) are at least equal to the longitudinal properties. Properties normal to the plane of the flange or web are not specified in the ordinary technical delivery conditions (e.g. in EN 10025-2, Ref 1).

Tensile strength properties for plate are specified by reference to transverse test specimens, unless the plate is less than 600 mm wide, when they are longitudinal. Impact toughness test specimens are usually aligned longitudinally. Again, no properties normal to the plane of the plate are specified in the ordinary technical delivery conditions.

The tensile strength out-of-plane (perpendicular to the surface) is more susceptible (than the in-plane strength) to the influence of rolling imperfections, particularly in plates.

There are two levels of imperfection or defect that affect out-of-plane behaviour:

- macro imperfections - thin layers of inclusion or impurity, extending over an area
- micro imperfections - numerous very small inclusions, usually of sulphides.

Macro defects are termed 'laminations' or 'laminar defects'. Their presence and extent can be checked by ultrasonic testing. Acceptance levels are given in EN 10160 (Ref 2). This type of defect is not the subject of this Guidance Note.

Micro imperfections are significant when the material is subject to through-thickness loading, because they can lead to 'lamellar tearing' as a tear propagates from one inclusion to the next. Since the inclusions are small they cannot readily be revealed by ultrasonic testing, but their effect may be assessed by carrying out through thickness tensile tests in accordance with EN 10164 (Ref 3).

Generally, the requirement for 'through thickness properties' is therefore understood to be a requirement for one of the three quality classes of improved deformation properties (Z15, Z25, Z35) defined in EN 10164.

**Evaluation of deformation properties perpendicular to the surface - EN 10164**

It is stated in EN 10164 that the reduction of area in a through thickness tensile test is a good general guide to the lamellar tear resistance, i.e. the risk of lamellar tearing decreases with increased reduction of area. Steel normally manufactured to the EN standards (e.g. EN 10025-2) generally has a modest tear resistance (i.e. a modest reduction of area), but this property is not specified or measured. The invoking of EN 10164, as a supplement to the product standard, implies that the steel will have *improved* deformation properties, as a result of additional steelmaking procedures. These improved properties may be specified in terms of a minimum reduction of area in a transverse tensile test; three quality classes are defined, Z15, Z25 and Z35, corresponding to 15%, 25% and 35% average reduction in area at failure, respectively.

**The need for steel with improved through-thickness properties**

There should be very little need to specify steel with improved (guaranteed) through-thickness properties in typical bridge steelwork, unless the joint details are unusual. The tear resistance of steels from modern steel-making plants is sufficient for most applications. If the

# Guidance Note

## No. 3.02

source of the steel material is uncertain and/or the manufacturer's or supplier's certification is incomplete and, especially, if the application is one of those recognised to be critical in this respect, testing to EN 10164 should be called for. The result will indicate in which category the material lies and its suitability for the application can then be assessed.

'Through thickness properties' would, for example, be needed where there is significant load carried through a cruciform detail, or where pieces are welded in positions where they are constrained against weld shrinkage. Good design of connections should ensure that there are rarely any such details.

It is worth noting the conclusion of a study carried out by TWI for TRRL in 1991 (Ref 4): "The review and survey of industry have shown that the principal factors controlling lamellar tearing are well understood, and that instances of this form of cracking in bridge construction are currently very infrequent." The report goes on to say that with the advent of options that offer "a range of through thickness tested grades, there is a risk that such steels will be specified in situations where they are not strictly necessary, thus adding unnecessarily to the overall cost". Refinements in steelmaking since 1991 are likely to have further reduced the instances of tearing.

### Avoidance of lamellar tearing

The main cause of lamellar tearing is very high out-of-plane stresses due to restraint of weld shrinkage. Tearing will usually appear during or soon after cooling of the welds; tearing due to applied load occurs rarely, unless tearing has already been initiated, or laminar defects are present.

The best way to avoid tearing is therefore to avoid details that induce high out-of-plane stresses. Where they cannot be avoided, it is recommended to check by ultrasonic testing locally around any critical details *after* welding, to ensure that there are no tears or defects.

### Details that avoid the risk of lamellar tearing

A simple corner butt weld can lead to tearing if the weld preparation is to the wrong plate. See Figure 1.

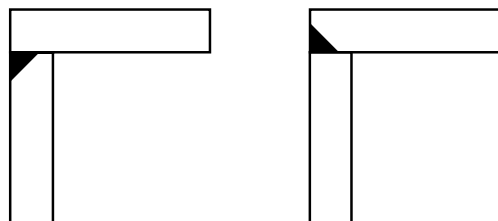

Poor detail  
(susceptible to lamellar tearing)

Better detail

**Figure 1** *Corner weld details*

When the upper plate in Figure 1 is prepared (as in the right-hand detail), the preparation cuts across most of any laminar defects.

If a cruciform detail is needed (for example when there are integral crossheads), consider running the thicker web plate through and weld the thinner to it, as in Figure 2. The thinner web is unlikely to require very large welds and thus should not require consideration of through-thickness. In any case, try to remove the need for full penetration welds: fillet welds and partial penetration welds are less likely to give rise to problems.

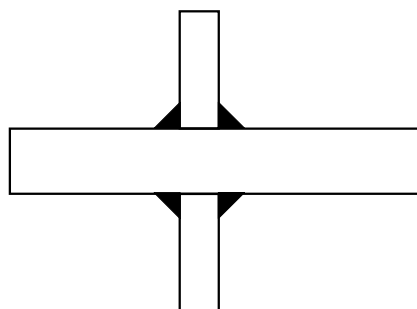

**Figure 2** *Cruciform detail*

If a full penetration butt weld detail is needed (perhaps because of its better fatigue classification), there is again a lesser risk of tearing if the thicker plate is passed through; then no requirement for through thickness properties need normally be specified. See Figure 3.

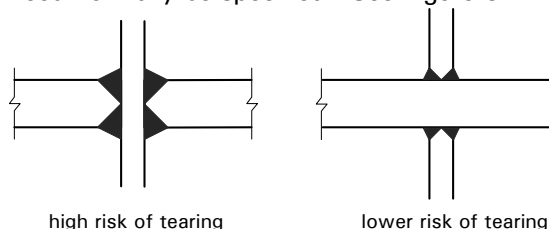

**Figure 3** *Cruciform details using butt welds*

**Specification of steel with improved deformation properties**

Specifying a quality class to EN 10164 will ensure that the steel supplier provides a fine grained steel, with a sulphur level lower than that normally encountered with ‘ordinary’ structural steels. In addition to the usual properties, the steel will have a ‘guaranteed’ level of through thickness ductility.

However, steel with improved deformation properties should only be specified if the designer perceives a risk of lamellar tearing. Such a perception should be made after taking a balanced view, not simply as a belt-and-braces safe option. The advice in this Note should aid the designer to make a reasoned judgement.

EN 1011-2 (Ref 5) provides in its Annex F some guidance on the relationship between the reduction of area in the transverse tensile test and the risk of lamellar tearing in joints of differing restraint. This is presented in tabular form in Table 1.

Annex F also contains advice on the best ways of avoiding lamellar tearing problems.

**Table 1** *Relationship between reduction in area and risk of tearing*

Reduction in area	Type of joint at risk
Up to 10%	Some risk in lightly restrained T-joints, e.g. I-beams
Up to 15%	Some risk in moderately restrained joints, e.g. box-columns
Up to 20%	Some risk in highly restrained joints, e.g. node joints, joints between sub-fabrications
Over 20%	Probable freedom from tearing in any joint type

If a designer has concerns in relation to any details, advice could be sought from experienced fabricators prior to contract.

Another simple rule-of-thumb is to expect problems when the size of the attachment by weld to a plate surface matches or exceeds the thickness of that plate.

EN 1993-1-10 (Ref 6) contains a numerical method for determining the required Z-grade according to the weld size, detail type and

level of restraint. However, the UK National Annex (Ref 7) indicates that this should not be used. The view of the UK experts is that this method is unduly conservative, required extensive calculations, and would lead to the unnecessary specification of Z-grade material. Instead, the UK National Annex refers designers to PD 6695-1-10 (Ref 8), which gives:

- Options for the fabricator.  
The PD points out that the risk of ‘lamellar tearing’ can be mitigated by fabrication control measures, notably by procuring material from a modern mill known to produce clean steel.
- Options for the designer.  
The PD implies that Z-grade material need not be specified for low and medium risk situations. For high risk situations it recommends that designers should specify Z35 quality to EN 10164. It defines high risk situations as:

In T-joints, when  $t_z > 35\text{mm}$ .

In cruciform joints, when  $t_z > 25\text{mm}$

Where  $t_z$  is the thickness of the incoming plate for butt welds and deep penetration fillet welds, and is the throat size of the largest fillet weld for fillet welded joints.

**Material availability**

Requirements for improved through-thickness properties are usually very local in nature. However, steel with improved properties is more expensive and less readily available. If restricted portions of web or flange are specified in such steel, it is likely that only small quantities will be needed on any particular project. This may prove difficult for the fabricator, because the supplier may impose minimum order quantities, with a premium for small quantities. These practical considerations should be recognised by the designer; *it is better to design details that do not require the use of steel with improved through thickness properties.*

**Avoidance of laminar defects**

Wherever load-carrying connections are made to the surface of steel, whether transmitting shear or out-of-plane forces, laminar defects should either be absent or of limited extent, irrespective of any need for through thickness

# Guidance Note

## No. 3.02

---

properties. For critical details (such as lifting cleats or bearing stiffener connections to a web), ultrasonic inspection can be carried out before fabrication, as a precaution. Specification of a quality class to EN 10164 invokes a requirement for ultrasonic inspection as well as for through thickness properties.

### References

1. EN 10025-2:2004, Hot rolled products of alloy structural steels. Technical delivery conditions for non-alloy steels.
2. EN 10160:1999, Ultrasonic testing of steel flat plate product of thickness equal to or greater than 6 mm (reflection method).
3. EN 10164: 2004, Steel products with improved deformation properties perpendicular to the surface of the product. Technical delivery conditions.
4. Study of through thickness properties of steel for bridge construction, Report 3-4048/3/91, The Welding Institute, 1991 (unpublished)
5. EN 1011-2:2001 Welding. Recommendations for welding of metallic materials. Arc welding of ferritic steels
6. EN 1993-1-10:2005, Eurocode 3: Design of steel structures - Part 1-10 Material toughness and through thickness properties, BSI, 2005
7. NA to EN 1993-1-10: 2005, UK National Annex to Eurocode 3: Design of steel structures – Part 1-10: Material toughness and through-thickness properties, BSI, 2009
8. PD 6695-1-10:2009, Recommendations for the design of structures to BS EN 1993-1-10, BSI 2009.

**Scope**

This Guidance Note provides information on the types of bearings which are normally used in steel bridges. The intention is to provide guidance as to what type of bearings should be used to suit particular bridge forms. Fuller descriptions of some bearing types, with illustrations, are given in Lee (Ref 1) and the *Steel Designer's Manual* (Ref 2).

In order to select the most appropriate type of bearings it is necessary to consider the articulation of the bridge deck and its overall stability under loading. Information on bridge articulation is given in GN 1.04. Information on the attachment of bearings is given in GN 2.05.

**General**

In the majority of steel bridges it is convenient to use proprietary bearings, provided appropriate testing and/or design checking procedures can be satisfied. However, steel fabricated bearings can often be economic, especially in uplift situations, for fixed end bearings, or where large rotations occur, as in roll-on/roll-off link spans and moveable bridges.

Whether bearings are proprietary or fabricated, their design and manufacture must conform to EN 1337 (Ref 3). That Standard comprises numerous separate parts, relating to general rules, and rules for individual types of bearings or components of bearings. The task of the bridge designer is to define a schedule of forces and displacements that the bearing is to be designed for - see later comment.

Where bearings have to resist uplift, special bearings normally have to be designed and manufactured. Hence uplift bearings are best avoided, if necessary by modifying the design concept. For lightweight structures such as footbridges, consideration should be given to providing separate and robust hold-down devices to prevent dislodgement under accidental impact or theft.

It is now general practice for the designer to make provision for the replacement of the bearings during the lifetime of the bridge and this practice is endorsed in PD 6703 (Ref 4). This usually means that, except for light footbridges, provision for jacking should be designed for and incorporated into the works. Arrangements for fixing by bolting should be such that the bolts

can be removed without needing to lift the bridge girders significantly.

Particular attention should be given to the design of supporting concrete plinths to prevent bursting or other types of failure from application of both vertical and horizontal forces.

**Types of bearing**

Table 1 shows the main types of bearing that are used in steel bridges. Generally, the terminology used in EN 1337 is adopted in the Table although not all types of bearing are covered by EN 1337.

The most frequently used type of bearing for highway bridges is the proprietary pot bearing, which is able to accommodate rotation and, where required, lateral movement in either longitudinal or transverse directions, or in both directions. Such bearings are particularly suitable for continuous and curved viaducts.

For railway bridges or footbridges, fabricated linear rocker bearings are often suitable at both ends for simply supported spans up to about 20 m. For rail bridges of span greater than 20 m, fabricated roller/rocker bearings can be used at the free end. Line rocker bearings are of benefit in some half through type rail bridges in resisting transverse rotation at supports (applies to both plate girder type bridges with U-frame action and standard box girders with pin connected floors - see GN1.04 for further comment).

For footbridges and short span road bridges, elastomeric bearings are often used. For short footbridge spans supported by steel columns, bearings may be omitted altogether and replaced by a direct bolted cap plate connection, which allows thermal movements and articulation to be accommodated by flexure of the columns.

Some brief guidance on commonly used bearing types is given below.

**Pot bearings**

Pot bearings comprise a circular elastomeric disc constrained by a metal housing (forming a cylinder and piston) which allows high pressures to be used such that resistance to articulation is negligible. Free bearings (i.e. allowing horizontal translation) are achieved by incorporating a



# Guidance Note

## No. 3.03

PTFE/stainless steel interface, usually arranged as shown in Figure 1.

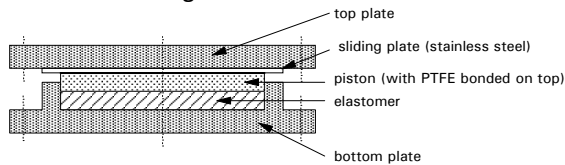

**Figure 1** Free-sliding pot bearing

With this arrangement, when movement occurs (due to expansion/contraction) the reaction becomes eccentric to the superstructure above. This eccentricity can be avoided by inverting the entire bearing assembly, but the sliding surface is then vulnerable to collecting debris, and should be shrouded by providing a skirt around the bearing (see further comment in Figure 3 of GN 2.08).

The friction on the sliding surface depends on the PTFE interface pressure and is typically 5%.

If the sliding element is omitted, pot bearings provide horizontal restraint. Alternatively, the sliding element may be constrained by guides, creating a unidirectional guided bearing.

### Elastomeric bearings

These may be of strip, rectangular pad or laminated type (see Figure 2), the latter being available typically up to 1000 kN capacity. Design is governed by SLS requirements, to control excessive distortion of the material.

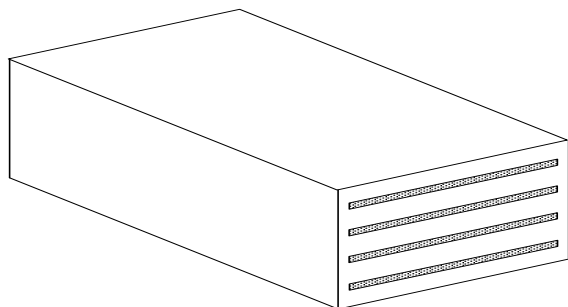
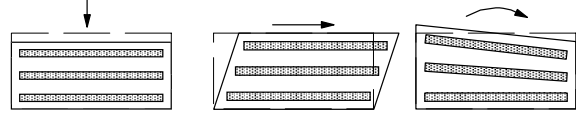

**Figure 2** Laminated elastomeric bearing

For loads in excess of 1000 kN, the bearings may become uneconomically large, such that additional spreader plates and stiffening of the steelwork become necessary. Thus elastomeric bearings are rarely used for steel highway or railway bridges.

Movements and rotations are achieved by deformation of the elastomeric material such that

moving parts are completely avoided. See Figure 3.

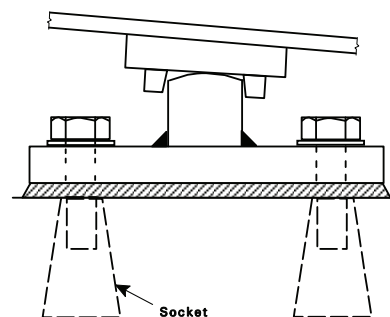

**Figure 3** Deformation of elastomeric bearings

It is essential to retain bearings in position by steel keep-strips attached to the steelwork above and the spreader plate below. Movement is restricted to about 40 mm from the mean position. Elastomeric bearings are unsuitable as fixed bearings, unless the forces are small; some other form of restraint would be needed to carry larger forces and this would usually be expensive and might inhibit maintenance.

### Linear rocker bearings

These bearings provide a very economic solution in that they can be supplied by the steelwork fabricator. As well as economic advantages that this gives, it may also give more assurance that there is a good match between hole positions in bearings, tapered bearing plates and girder flanges, as well as reducing the risk of delay in the procurement process (see further comment below). See Figure 4.



**Figure 4** Fabricated line rocker bearing (inclination of girder exaggerated)

The rocker surface is normally machine radiused. The design capacity depends on the radius, as well as on the material properties.

A convenient method of attaching fabricated bearings to the substructure in a way that allows for construction tolerances is to site weld the lower part of the bearing to a larger baseplate that is fixed to the substructure before steelwork erection.

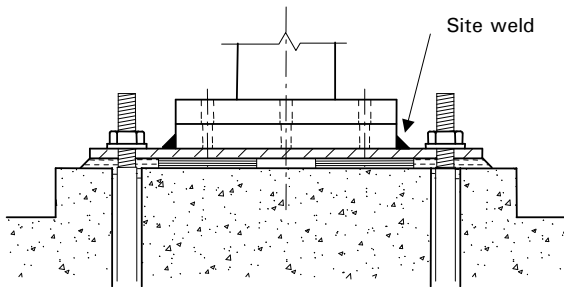
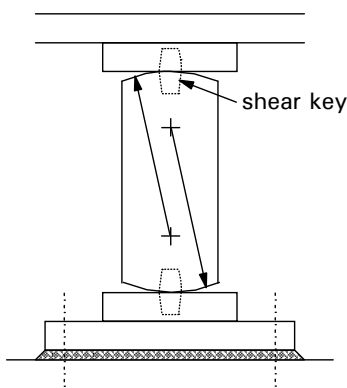

**Figure 5** *Detail of site welding to baseplate*

When designing a linear rocker, the maximum eccentricity of the reaction (due to the restraining torque that the bearing provides) needs to be considered carefully (there is no tensile restraint at the line of contact).

**Roller/rocker bearings**

These bearings are suitable for situations where only longitudinal movement and articulation occur, and where transverse rotation is to be prevented. In order to reduce bearing height, the upper and lower curved surfaces can be radiused from different axes (see Figure 6), but this arrangement means that under longitudinal movements, the superstructure will tend to lift, creating additional longitudinal forces which must be designed for. This type of bearing is used at the free end of standard box girder rail bridges for spans exceeding 20 m.



**Figure 6** *Fabricated roller/rocker bearing*

Guides are provided to ensure that the bearings remain normal to the direction of movement and shear keys are provided at each end to transfer lateral loads and prevent crabbing.

**Roller bearings**

Steel roller bearings usually comprise a single cylindrical roller of high strength or case hardened steel to increase the load capacity and to minimise friction. This type is used where friction

is to be minimised and is suitable on leaf piers. It shares the displacement equally between sub- and superstructure.

Guides are provided to ensure against crabbing. However, alignment of the roller axis normal to the direction of the steelwork movement is critical, particularly on long viaducts, where the movement is significant.

It should be noted that some types of high strength steel exposed to the environment under loading for roller bearings may be susceptible to cracking problems and for these reasons the bearing is normally enclosed within an oil-bath.

Roller bearings are now rarely used.

**Pin and swing link bearings**

These bearings (also known as pendel bearings) are used where the amount of articulation exceeds that of proprietary bearings as in roll-on/roll-off link spans. They are also used in order to resist overturning and/or theft. They are not covered by EN 1337.

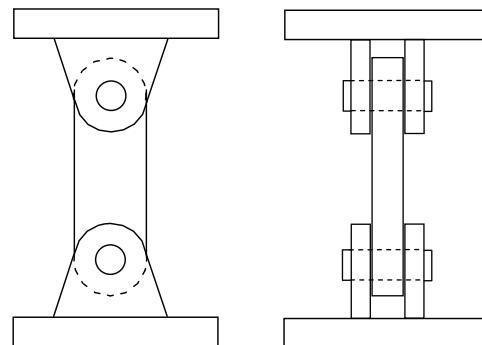

**Figure 7** *Swing link expansion/uplift bearing*

**Guide bearings**

Occasionally, where lateral loads at a support are large in comparison with the vertical loads, separate guide bearings are used to resist lateral loads only. This situation can arise in long viaducts where lateral forces are only resisted at some supports, or in cable supported bridges. Proprietary sliding plate or pin type guided bearings are available for small loads, but guide bearings are usually purpose-designed.

**Specification of bearings**

The designer should prepare a bridge bearing schedule for the bearing manufacturer. A typical bearing schedule is given in EN 1993-2 but that format is unsuitable, since it provides only for

# Guidance Note

## No. 3.03

---

characteristic values of the effects of individual actions and the bearing designer would need to know the appropriate partial factors and combinations of actions, which is outside his responsibility. A different schedule is given in EN 1337-1 but even that is not entirely clear about which effects are coexistent or in which design situation they occur. A better schedule is provided in PD 6703 and it is proposed to provide a template schedule in a future revision of EN 1990.

In the absence of an adequate 'typical' schedule, early discussion between bridge designer and bearing designer is recommended.

The design of the bridge including steelwork stiffening, bearing plates and support on the substructures, should be carried out by the designer, assuming either one proprietary make based on catalogue or other information from an approved supplier, or that there are project-specific bearings for which the full details are given in the project documentation. The drawings should then clearly permit the contractor to offer different bearings, provided that all design criteria can be met.

EN 1337 contains specification clauses relating to inspection and testing procedures, including the provision of testing procedures for proprietary bearings.

### **Procurement of proprietary bearings**

Whilst the provision of a comprehensive bearing schedule gives a basis for competition between bearing suppliers, it should be noted that the time for gaining approval of selected bearings is often very long. It is all too common for the bearing details to be outstanding after the main body of the steelwork has been fabricated - sometimes even after protective treatment. It is essential to progress bearing procurement as quickly as possible, and to remember that it is false economy to save a little on the cost of the bearings at the expense of delay to the rest of the job.

### **Robustness**

Most bearings, purpose-fabricated or proprietary, are extremely robust and give little trouble in service. The only problems that can be said to occur quite often are contamination of, and hence damage to, sliding surfaces, caused by leakage from the deck washing grit onto the interfaces.

This problem can be avoided by careful detailing of bearing attachments and/or the provision of skirts (see Figure 3 of GN 2.08 for an example of a skirt).

There have been some very occasional problems with elastomeric and hardened steel roller or ball bearings caused by high frequency vibration of the bridge structure. The rubber degrades into dust; the steel surfaces develop micro-cracking

### **Location plates for railway bridge bearings**

It is normal practice for bearings for railway bridges to be positioned on location plates bolted to the abutment, particularly when superstructures are reconstructed on existing abutments during possessions. The lower bearing plate is site welded to the location plate. Location plates offer the following advantages:

- They provide tolerance on the final position of the bearing relative to the abutment.
- Longer holding down bolts may be used to fix the location plates than could be used for the narrower base plates (because of the restricted clearance between the lower bearing plate and the underside of the bridge girder).
- They achieve greater load distribution and therefore reduce bearing stresses on the abutment (this is particularly relevant on brickwork abutments and may enable the depth of sill beams to be reduced).
- The bearing installation period required in a possession can be minimised, because location plates can be installed as soon as the abutment is ready and before the bridge superstructure is erected.

### **Bearings in integral bridges**

In fully integral bridges, there is no translational movement between superstructure and substructure. In some types of integral bridge, line rocker bearings may be provided, to allow relative rotation. Such rocker bearings could be either proprietary or purpose-made; provided that the steelwork is properly protected against corrosion, they should be maintenance-free.

In some types of jointless or semi-integral bridge, sliding bearings might be used, with longitudinal and lateral restraint being provided by earth pressures on the endscreen walls across the end of the superstructure.

### References

1. Lee, DJ, Bridge bearings and expansion joints, 2nd edition, E & FN Spon, 1994.
2. Matthews, SJ, Bearings and joints, Chapter 28 in the Steel Designers Manual, Blackwell Science (Sixth Edition), 2003.
3. EN 1337 Structural bearings
  - Part 1 General design rules
  - Part 2 Sliding elements
  - Part 3 Elastomeric bearings
  - Part 4 Roller bearings
  - Part 5 Pot bearings
  - Part 6 Rocker bearings
  - Part 7 Spherical and cylindrical PTFE bearings
  - Part 8 Guided bearings and restrained bearings
  - Part 9 Protection
  - Part 10 Inspection and maintenance
  - Part 11 Transport, storage and installation
4. PD 6703 Structural bearings. Guidance on the use of structural bearings, 2009.

# Guidance Note

## No. 3.03

**Table 1 Types of bearings**

Type	Common capacity range (kN)	Supply	Typical friction	Use	Limitations	General comments
Pot	500-30,000	Proprietary	0.05	> 20 m span	Rotation capacity 0.01 radians	Widely used
Elastomeric strip	200-1,000	Proprietary	4-10 kN/mm	Short span > 10 m	Limited translation and rotation	Economic for short spans
Elastomeric pad	10-500	Proprietary	0.5-5.0 kN/mm	Short spans - light loads	Limited translation and rotation	Useful for light loads
Elastomeric laminated	100-1,000	Proprietary	0.5-5.9 kN/mm	Short spans	Heavy loads	Widely used
Cylindrical roller	1,000-1,500	Proprietary	0.01 (single roller hardened)	Minimal friction	Nil lateral translation or rotation	Little used. Guides essential
Linear rocker	1,000-10,000	Fabricated	0.25	Fixed bearings. Rail bridges	High friction. Nil lateral rotation	Large rotation
Cylindrical knuckle	2,000-10,000	Fabricated	NA	Pinned bearings. Base of steel portal	Unsuitable translation or lateral rotation	Little used
Plane sliding	100-1000	Proprietary	0.005	Sliding guides with large translation	Small rotation capacity	Suitable very short span (say < 5 m) where rotation negligible
Spherical sliding	1,000-12,000	Proprietary	0.05	> 20 m span	More expensive than pot	Rotation capacity 0.05
Guided	150-1,500	Proprietary	0.05	Horizontal load only	Carries no vertical load	Used when guide bearing essential, e.g. end of long viaduct or wide bridge
Pin	10-1,000	Fabricated	NA	Fixed with uplift	Nil translation or lateral rotation	Useful for footbridges for security or uplift
Swing link	10-1,000	Fabricated	Control by link length	Guided with uplift	Nil lateral translation or rotation	Useful for footbridges for security or uplift

## Welding processes and consumables

No. 3.04

**Scope**

This Guidance Note is intended to give the reader who is not familiar with arc welding an insight into the types of welding equipment and consumables commonly used in steel bridge fabrication.

**Welding processes**

Welding processes generally fall into one of four principal groups:

- manual metal arc welding
- gas shielded metal arc welding
- self shielding flux cored welding
- submerged arc welding.

Within each group there are variations in equipment and consumables, and there are many individually identified sub-groups. The most common processes, numbered in accordance with EN ISO 4063 (Ref.1), are explained below.

**Manual metal arc welding (MMA) process (Process 111)**

This is a widely used and highly versatile process. Although its use in shop fabrication has diminished over recent years, it is still used extensively on site.

The process is manually operated using individual flux-covered electrodes (often called rods) that are inserted into an electrode holder held by the welder. The process is sometimes known as 'stick welding'. The resulting weld is covered in slag that has to be removed mechanically, usually with a chipping hammer.

Shop equipment operates on alternating current (AC) via a mains transformer or on direct current (DC) via rectifiers or inverters. The most commonly used site equipment operates on direct current (DC), powered by a diesel engine generator. However, AC diesel powered equipment is also available.

There are advantages and disadvantages to each process:

- Virtually all electrodes will operate satisfactorily on DC, but special flux compositions are required to give a stable arc with AC.
- AC equipment is generally simpler and more robust than DC equipment.

- AC equipment requires a greater open circuit voltage, which may be a safety problem outside the workshop.
- The DC arc can be difficult to control, because of magnetic effects. This is known as arc-blow.

Electrodes commonly used are between 3.25 mm and 6 mm diameter and typically 450 mm long. The core wire is usually a low alloy steel wire, alloy addition is usually via the flux covering. Iron powder is often combined in the flux to improve deposition rates.

A wide variety of covered electrodes is available, from a considerable number of manufacturers, covering a wide range of welding requirements.

'Basic' covered electrodes are normally used in bridge construction. The main constituents of the flux covering are calcium carbonate and calcium fluoride. Following proper drying and storage, these electrodes are commonly known as hydrogen controlled, and produce joints with very good mechanical properties.

Basic electrodes must be stored with care to ensure that they do not absorb moisture which could generate hydrogen in the weld pool. Storage in a temperature controlled oven is the normal practice, with transfer to heated quivers at the point of welding.

Consumable manufacturers now also offer specially sealed packs that guarantee very low levels of diffusible hydrogen if the electrodes are used within the manufacturer's specified period after first opening the sealed pack. These packs are very useful if the amount of welding to be carried out is relatively small and the setting up of a temperature controlled oven would not be practical.

Deposition rates are relatively low with MMA, usually in the range of 1 to 1.5 kg/hr, as the process is not continuous. For the typical heat inputs and welding electrode diameters used in bridge construction, the length of weld from each electrode used in the downhand position is in the order of 200 to 300 mm, so there are many stop-starts when using this process.

# Guidance Note

## No. 3.04

---

### **Gas shielded metal arc welding process (Process 13)**

The process is mainly used in manual mode and utilizes a continuously fed consumable wire from a wire feed unit to a welding gun held by the operator. A shielding gas to protect the arc is also fed through the gun.

Continuously fed wire and shielding gas also make this process well suited to automated welding.

At low welding currents, the consumable wire undergoes 'dip transfer' to the welding pool. The welding gun feeds consumable wire until the wire tip touches the weld pool; short circuiting then takes place, which melts the end portion of the wire and breaks the arc momentarily. The process repeats as the wire is constantly fed. This mechanism is useful for achieving good control in positional welding, but can be prone to lack of fusion defects.

At high welding currents the transfer of the consumable wire to the weld pool is by spray transfer where the consumable wire melts in the welding arc and is transferred along the arc to the weld pool.

The first shielding gas to be widely used was CO<sub>2</sub>. Consequently the process was commonly known in its early years as CO<sub>2</sub> welding. However, the use of CO<sub>2</sub> alone as the shielding gas limits the process to use at lower welding currents.

Today the most commonly used shielding gas is a mixture of argon and CO<sub>2</sub>. Using this mixture dip transfer can still be achieved at lower welding currents, but higher welding currents and deposition rates can also be achieved.

After the advent of gas mixtures, the process began to be referred to as MIG (metal inert gas) welding.

Later it was realized that the gases were doing more than merely shielding the arc and that changes to the gas mixture could affect weld bead shape, deposition rates, fusion, and weld metal properties. The process was then termed MAG (metal active gas) welding.

It is possible that the reader may hear the process referred to by any of the three (CO<sub>2</sub>, MIG or MAG), and to confuse the issue still further the American term, gas metal arc welding (GMAW), may also be used, but all four processes are essentially the same.

MAG is now the formally recognized terminology in the UK.

The gases used for bridgework are mostly mixtures of argon and CO<sub>2</sub>. The proportion of CO<sub>2</sub> varies between about 5% and 20%.

The MAG process is mainly used in the fabrication shop, although its use is growing on sites in this country and it has been widely used on sites in the USA for some years. The process uses DC via a rectifier, and the electrode is normally positive (DC+).

The most commonly used consumable wire diameter is 1.2 mm. Wires are usually supplied on 15 – 18 kg reels. Larger reels can be obtained for use with robotic equipment.

Wires come in three main categories:

- 1) Process 135: Solid wire, where the wire itself provides the required alloys. Deposition rates in the order of 3 kg/hr are typical. Wires are supplied with a copper coating for improved feeding and connectivity, however many steelwork contractors prefer copper free wires. There are advantages for both products.
- 2) Process 136: Tubular flux cored wires (flux cored arc welding, FCAW), where the wire is hollow and filled with flux. Alloying is derived from the flux or wire, or both. These wires can give deposition rates in the 3 to 3.5 kg/hr range. The type of flux can vary from rutile (titanium oxide), which gives the best positional performance, to basic flux (calcium carbonate) which gives better mechanical properties but is best suited to work in the flat position.
- 3) Process 136: Tubular metal cored wires (metal cored arc welding, MCAW), where the continuous wire is again hollow but filled with iron powder. Alloying elements are mainly contained in the continuous wire, but can also be present in the core. Deposition rates of the order of 4 kg/hr can be

achieved. MCAW can be used for positional welding, but high skill levels are required from the operator, and it is therefore mostly used for work in the flat position.

Development continues on suitable power sources. There are at present two variants:

- 1) Synergic systems. These systems control the melting process of the consumable electronically, in order to mimic the characteristics and control of the dip transfer mode but at higher welding currents and deposition rates. The operator has a single control and all welding parameters are automatically co-ordinated from that control.
- 2) Pulsed arc. This system is intended to achieve the same end result as the synergic system, but each welding parameter can be controlled independently.

### **Self-shielded tubular-cored arc welding process (Process 114)**

This process (often known by the proprietary name 'Innershield') is much the same as FCAW, but relies on the flux contained within the consumable wire alone to generate the shielding gas.

This process was very popular in the 1980s. It gave good positional control and good deposition rates compared with MMA welding.

The process develops relatively large amounts of welding fumes, so much so that special measures are needed for fume extraction. In addition, the welding slag is classified as contaminated waste and requires special arrangements for disposal. As a result, use of the process has diminished, but if the problems are overcome in the future the process may regain popularity.

### **Submerged arc welding (SAW) process (Process 12)**

Submerged arc is a continuous welding process utilizing solid wire electrodes where the arc is submerged in, and is shielded by, a granular flux.

The process is mainly used in automatic or semi-automatic mode. Hand-held versions

have been developed, but are not widely used. It is not suitable for positional welding; its use is restricted to the flat and horizontal-vertical positions.

It is mainly used as a DC process and can be operated as either electrode positive (DC+) or negative (DC-). The DC+ mode is the most commonly used and gives a high degree of penetration. AC versions are available but are not commonly used in bridge construction

Submerged arc welding is mostly used in the fabrication shop, where a mains powered rectifier unit provides the welding current. It has been used on larger bridge sites for butt welds in orthotropic decks. For this application large diesel powered alternators are needed to feed the rectifier unit. The rectifiers usually need some modification and weather proofing to function reliably and safely in the site environment. Large amounts of welding are necessary to justify the use of SAW on site.

SAW equipment is commonly used mounted on tractors, gantries, columns and booms, T&I plate girder machines, deck panel assembly machines and pipe welding machines.

High quality butt welds with excellent mechanical properties, and fillet welds with high penetration and good profile can be achieved with this process. Many flux/wire combinations are available to deal with a multitude of welding situations and requirements.

Single consumable wires of 4 mm diameter are the most commonly used in bridge construction. Deposition rates in the order of 6 kg/hr are achieved in production. Alloying generally comes from the solid wire consumable (process 121), or occasionally from the flux. Tubular flux cored wires (process 125) are increasingly being used to enhance the mechanical properties of the welded joint and to increase productivity.

Twin wire systems (process 123) with the consumable wires fed through a common welding tip are also used and have the benefit of increasing deposition to over double that of the single wire system. Each wire is typically up to 2 mm diameter.



# Guidance Note

## No. 3.04

---

Multiple wire versions (process 123), where two or more wires feed through separate welding tips, are also available. These systems are complex and require accurate control and guidance but they are able to achieve very high deposition rates.

Iron powder addition attachments (process 124) which allow deposition rates of up to 20 kg/hr are also available.

Most of the work and skill in using the SAW process is in setting up the equipment. Therefore, even in the fabrication shop, it tends to be economic only for those joints requiring large volumes of weld metal.

The process is quiet in operation, virtually no fumes are created, and as the arc is totally submerged in the flux no ultraviolet light is emitted.

The operator does not require as much personal protective equipment (PPE) as with the other processes.

### **Ceramic backings**

Ceramic backing strips originated in the ship-building industry to enable single sided butt welds to be made without the need to fix and

leave in place steel backing strips. They have been used extensively in bridge construction over the last thirty years or so.

Ceramic strips of various shapes are available to fit in the roots of butt welds. The root run is then deposited using the ceramic to support the weld pool. The ceramic can then be chipped away after the weld has cooled.

High depositions are possible in the root run and back gouging of the root can be minimized or avoided.

Ceramic backings work well with the MAG processes and MMA. With care, they can also be used with the SAW process.

The ceramic backings are non-hygroscopic, so the hydrogen performance of the welding process is not impaired and because there is no alloy transfer to the weld pool, there are no adverse effects on the mechanical properties of the weld.

### **Reference**

1. EN ISO 4063:2000, Welding and allied processes- Nomenclature of processes and reference numbers.

## Surface defects on steel materials

No. 3.05

**Scope**

This Guidance Note describes the requirements for surface condition of steel materials, as delivered from the supplier. Pitting due to rusting is covered in GN 8.01.

**General**

Steel supplied from the mills will have been visibly inspected and any repairs carried out (where allowed) before delivery. Material with unrepairable defects will have been rejected. However, the steel is not usually blast cleaned, and still has mill scale adhering to it. Consequently, the surface that is revealed after grit/shot blasting may show surface discontinuities that were not visible before.

The requirements relating to surface condition of hot rolled steel products are given in EN 10163 (Ref 1). That Standard refers to 'imperfections' (discontinuities that may be left without repair) and to 'defects' (that shall be repaired). Repair procedures are covered. The Standard explains that discontinuities could include: rolled-in scale; pitting; indentations and roll marks (depressions and protuberances due to roll wear); scratches and grooves; spills and slivers (elongated flake-like discontinuities); blisters; sand patches; cracks; shells (overlapping material with non-metallic inclusions); and seams (elongated defects). Some of these discontinuities are rarely seen in steel produced by modern processes.

There is good reason to discover any surface discontinuities early in the fabrication process, since unacceptable or unrepairable defects may result in the rejection of a completed fabrication (with all the associated cost implications). A prefabrication blast will usually reveal all those that are likely to be unacceptable.

In EN 10163 a number of classes and subclasses are defined. The specifier can select a requirement class appropriate to the intended use of the material.

**Imperfections and defects**

Four classes of surface condition are defined, two for plates and wide flats, two for sections. For each class, small imperfections (up to specified limits) are acceptable. Larger imperfections (and extensive small imperfections)

are considered to be defects and must be repaired, but there are limits to the remaining thickness under the defect.

The four classes of surface condition are:

*Class A (plates)*

Shallow depth imperfections, other than cracks, shell and seams, are acceptable; defects, including cracks shell and seams, must be repaired.

*Class B (plates)*

Similar to class A, except that the remaining thickness under any imperfection or defect may not be less than the minimum thickness allowed by the thickness tolerance standard (EN 10029) (Ref 2).

*Class C (sections)*

Modest depth imperfections (up to 3 mm deep in thick sections), are acceptable; deeper defects must be repaired.

*Class D (sections)*

Shallow depth imperfections (less deep than the limits in class C) are acceptable; deeper defects must be repaired.

Limiting depths relating to these classes are given in EN 10163.

**Repair of defects**

Three subclasses of surface condition specify how defects may be repaired.

*Subclass 1*

Repair by chipping and/or grinding followed by welding is permitted.

*Subclass 2*

Repair by chipping and/or grinding followed by welding is permitted only if agreed at the time of order.

*Subclass 3*

Repair by welding is not allowed

**Surface conditions for bridge steelwork**

It is generally considered that for bridge steelwork, repair of material by welding is not acceptable, because there would be no control over the final location of any repairs (and probably no record either); such repairs could therefore end up in fatigue-prone zones and result in premature failure. Subclass 3 should therefore be specified for both plates and sections.

For plates, class A permits imperfections that have a remaining thickness less than the

# Guidance Note

## No. 3.05

---

minimum tolerance value, provided that these are over a small proportion of the surface, whereas class B prohibits all imperfections that are deeper than the minimum tolerance value. It is generally accepted that class A3 is adequate for bridge steelwork.

For sections, class C accepts deeper imperfections than class D. In class D shallower imperfections would be considered defects and would have to be repaired. It is generally considered that class C3 is adequate for bridge steelwork.

The requirement for compliance with classes A3 and C3 is included in the *Model project specification* document (Ref 3).

When subclass 3 is specified, repair of an unacceptable defect by welding is not allowed, as stated above. If such a defect is revealed only after the material has been incorporated

into a fabricated assembly, the question is likely to arise as to whether it can be repaired. Strictly, the material as supplied did not comply with the specified requirements and can be rejected, but it is open to the purchaser to judge the situation on its merits, considering the fitness for purpose of a repaired component.

### References

1. EN 10163, Delivery requirements for surface condition of hot rolled steel plates, wide flats and sections.  
Part 1: 2004, General requirements.  
Part 2: 2004, Plates and wide flats.  
Part 3: 2004, Sections.
2. EN 10029: 1991, Specification for tolerances on dimensions, shape and mass for hot rolled steel plates 3 mm thick or above.
3. Model project specification for the execution of steelwork in bridge structures (P382), SCI, 2008.

**Scope**

This Guidance Note describes the requirements for limitations on internal imperfections in steel plate materials. Mention is also made of imperfections in rolled sections

The guidance relates to steels manufactured in accordance with current British and European standards. Although the descriptions may also assist in the assessment of older materials, further guidance should be sought for such purposes.

**Terminology**

Discontinuities within the body of the plate were previously referred to by names descriptive of the nature of the imperfection, for example lamination, inclusion, inclusion cluster, banding (of inclusions). The present BSI practice is to use a generic term - *internal imperfections* - and to classify them by area, length, breadth and population density

Note the distinction between an 'imperfection', which indicates a feature that is less than perfect but which does not prevent the component from being fit for purpose, and a 'defect', which is a larger discontinuity that does impair performance and may require rectification.

**General**

Steel plate is produced by a process of rolling thick slab of steel into approximately rectangular plates. During the process the material is passed through rollers many times, each pass resulting in a decrease in thickness and an increase in area. Inevitably, the plate material produced by this process is anisotropic. Any discontinuities that may be present (for example porosity or non-metallics trapped in the cooling slab) are elongated in the direction of rolling and laminar in form.

Modern steels are generally very 'clean' and the size of such imperfections is generally small, although they may occur in clusters.

In early steels, and particularly in wrought iron, discontinuities could constitute a significant proportion of the plate area and the through-thickness performance of the plate could not be guaranteed.

After rolling, plates are usually sheared or flame-cut to a rectangular size at the mills. This may mask laminar imperfections at the edges/ends, though these may be revealed when the fabricator trims the plate

Laminar imperfections can occur within the body of a plate or at the edges. However, even mid-plate laminations may appear as edge laminations when the fabricator 'strips out' a flange or web from the rolled product.

Laminations of significant size (area) would impair the structural performance of welded attachments to the plate surface, and might even give rise to local buckling failures in an element under in-plane compression. Edge laminations would reduce the integrity of connections made at or near the edge of a plate, for example in box girders or fabricated channel sections. Edge defects would also create a potential weakness against corrosion, either as a result of entrapment of dirt or moisture behind a coating, or by making a discontinuity in the coating; any consequent local corrosion would tend to open the lamination and aggravate the problem.

Fortunately, laminar imperfections produced by modern steelmaking processes are usually modest in size and extent, and can be detected by ultrasonic testing (and visually on clean edges). The quality control procedures in modern steel mills can generally be guaranteed to detect any gross defects and prevent them from getting into the supply material. Problems usually only arise in material from older (and often uncertified) mills, which may be supplied through some stockholders.

**Acceptance levels for internal imperfections**

EN 10160 (Ref 1) defines four basic acceptance levels (designated  $S_0$  to  $S_3$ ) for imperfections within the 'material body', and five basic levels (designated  $E_0$  to  $E_4$ ) for imperfections at the 'material edge'.

EN 1090-2 (Ref 2) requires internal discontinuity class 'S<sub>1</sub>' to be specified for certain areas of plates (e.g. at welded cruciform joints), and gives the designer the facility to specify further areas requiring class 'S<sub>1</sub>' (e.g. at welded bearing diaphragms or stiffeners). Note, however, that clause 5.3.4 of EN 1090-2 could be a little

# Guidance Note

## No. 3.06

---

confusing about where class 'S<sub>1</sub>' must be specified: the width of 25 times the plate thickness should only be applied to webs and flanges where bearing diaphragms or single-sided bearing stiffeners are attached. The requirement should not normally be applied at non-bearing stiffeners or diaphragms or where bearing stiffeners are attached symmetrically on both sides of the web.

The *Model project specification* document (Ref 3) requires that locations where internal discontinuity class 'S<sub>1</sub>' is required are specified on the relevant drawings. It also advises that class 'E<sub>1</sub>' should be specified on the relevant drawings for the edges of plates where corner welds will be made on to the surface of such plates.

### **Remedial/repair procedures**

If a situation arises where unacceptable defects are discovered at a stage in the work when replacement is not practicable without jeopardizing the completion programme, there are various procedures that have been used successfully in the past to overcome the problems.

Note, however, that it is important that any repair conforms to the same required standards of workmanship as any other welding on the fabrication. Special attention needs to be given to the finishing and, where necessary, surface dressing, to ensure that the fatigue class of the repair is no worse than that required by the designer at that particular location. It is for this reason that no such repairs should be carried out until the formal approval of the Engineer/Designer is obtained: as is required by the Specification.

### *Repairs to edges*

Shallow edge imperfections, particularly those caused by the overlapping in rolling, can be dealt with by grinding in from the edge to make a groove suitable for welding, and employing an appropriate repair procedure. Where the edge imperfection is wider, usually part of an area of de-lamination in the middle of a larger plate which has been exposed by stripping into narrower pieces, the edges can be repaired as above and the wider area treated as below.

### *Repairs in the middle of plates*

In the very unlikely event of needing to carry out a repair to the middle of a plate, the affected area can be clamped together by use of preloaded bolts or by plug welding. If such a repair is contemplated, the size and spacing of any bolts or welds must be considered carefully. Plug welding might be suggested for better appearance, although it is very difficult to completely disguise a field of plug welds. A better solution is to cut out the affected area and let in a new piece of plate, if this can be done.

### *Testing*

Any weld repairs should be tested by an appropriate non-destructive testing technique.

### **Material with through thickness properties**

A requirement for material with through thickness properties is a different requirement from that limiting the extent of internal imperfections. However, specifying through thickness properties in accordance with EN 10164 (Ref 4) invokes a requirement for inspection for laminar imperfections of a high sensitivity. Such inspections should identify any significant imperfections.

See GN 3.02 for advice about the need for, and the means of specifying, through thickness properties.

### **Internal defects in rolled sections**

Rolled sections are susceptible to similar problems but, once again, the quality controls in modern manufacturing facilities should prevent unacceptable material reaching the market.

When dealing with older sections, or with products from less well controlled mills (such as might be supplied by a stockholder), there are sometimes inclusions in the corner of an angle or channel or at the web-to-flange junction of a beam or Tee. Except in very thin sections this would seldom be a structural or durability problem, but might need to be dealt with where a gusset or cleat is attached near the corner (angle/channel) or in the middle of the flange (beam/Tee).

### **Safety note**

The area of attachment of lifting lugs should **always** be checked for sub-surface defects, whether the material is plate or a section.

### **References**

1. EN 10160: 1999, Ultrasonic testing of steel flat plate product of thickness equal to or greater than 6 mm (reflection method).
2. EN 1090-2: 2008, Execution of steel structures and aluminium structures - Part 2: Technical requirements for steel structures.
3. Steel Bridge Group: Model project specification for the execution of steelwork in bridge structures (P382), SCI, 2009.
4. EN 10164: 2004, Steel products with improved deformation properties perpendicular to the surface of the product. Technical delivery conditions.



**Scope**

This Guidance Note describes the aspects that need to be specified to ensure that the steel material is of the strength and quality presumed when designing in accordance with the design Standard EN 1993-2 (Ref 1).

**General**

EN 1993-2 presumes that steel materials will be supplied in accordance with EN 1090-2 (Ref 2). Clause 5.1 of this European Standard states that structural steel products used for the execution of steel structures shall be selected from the following product standards:

For plates & open sections:

EN 10025 (Ref 3):

- Part 2 – Non-alloy structural steels
- Part 3 - Fine grain structural steels (Normalised / normalised rolled)
- Part 4 - Fine grain structural steels (Thermomechanical rolled)
- Part 5 - Weathering steels
- Part 6 - Quenched & tempered steels

For structural hollow sections:

- EN 10210-1 (Ref 4) - *Hot rolled*
- EN 10219-1 (Ref 5) - *Cold formed*

Where steels complying with the requirements of other specifications are offered, EN 1090-2 requires, in Clause 5.1, that their properties shall be specified. The implication is that the properties can be compared to those of the steels listed above to assess the suitability of the alternative material. For most of the requirements this is a sufficient control to ensure that there will be no problem in their use. However, with respect to weldability, the 'indication' is only the maximum carbon equivalent. As some of the characteristics of a weldment, e.g. the profile or surface finish, are sensitive to the actual chemical composition and/or the particular concentration of certain elements, substitution by steels of a different specification may have unexpected consequences.

**Requirements to be specified**

There are three basic categories of requirements that need to be specified:

- mechanical properties
- dimensional properties
- physical condition

These requirements are covered either in the execution standard (EN 1090-2) and the various supporting standards that it invokes or in the project specification (see Ref 7 for a Model Project Specification, MPS).

**Mechanical properties**

Mechanical properties are simply specified by reference to EN 10025-2, etc. (see GN3.01). These standards include 'Options' relating to the tests for properties, but none of these Options need be explicitly invoked in normal situations.

For some applications, it is necessary to ensure that the material has adequate tensile strength in the 'through thickness' direction. GN 3.02 gives more advice about the subject and makes reference to specification in accordance with EN 10164 (Ref 6).

**Dimensional requirements**

EN 1090-2 specifies a class A tolerance on plate thickness, except for EXC4, for which it specifies class B. In the UK, class A is considered appropriate for all execution classes - see the MPS. It should not be necessary to specify any other project-specific tolerances on other dimensional tolerances. Such matters are covered by the various standards invoked elsewhere

Nevertheless, it is prudent to be aware of these tolerances when designing, particularly in the design of connections. The tolerances on plates do not usually give problems, although extremely unfavourable combinations of tolerances on thick plates can give steps at bolted joints that are outside the allowable assembly tolerances and which may need additional packings. Problems are more common with rolled sections, both open and closed; if rolled sections are to be butted end-to-end, for example, the only practical solution is to try to secure all the material from a single source and rolling.

**Physical condition**

Unless there are particular requirements for a superior surface finish quality, there should be no need to make any additional reference to any other option for new material supplied by a manufacturer. The relevant European Standard



# Guidance Note

## No. 3.07

---

is EN 10163 (Ref 9), which is explicitly referenced in the standards for technical delivery conditions. If there is any doubt, the suggested wording of Clause 5.303 of the MPS can be used.

Sometimes, however, a proposal is made to use old material, from a stockholder or from the fabricator's own stock, which has become rusty. Commonly this arises from the requirement to provide a small amount of material of uncommon thickness. Inclusion of the following wording in Clause 5.304 of the MPS prevents the use of material with excessive corrosion or pitting:

"The surface of the steel material, before surface preparation and protective treatment, shall comply with rust grades A or B according to EN IS 8501-1. Material that is pitted, i.e. rust grades C or D, shall not be used."

The issue here is that it is difficult to remove the corrosion products from the deepest pits; such residues often lead to the premature breakdown of the protective treatment.

EN 1090-2 and the MPS requirements cover all that is necessary and ensure that surface defects, which arise in the rolling process, are treated in accordance with the standards designated in Clause 5.1. Note that the MPS specifies sub-class 2 to EN 10163, which prohibits repair of defects by welding; this avoids the risk of repaired areas occurring in fatigue-sensitive locations.

GN 3.05 and GN 3.06 are relevant to surface and internal defects in steel materials, as supplied, and should be consulted.

### Inspection and testing

EN 1090-2 and the MPS cover all the normal requirements for inspection and testing of the finished product. This includes such things as the marking for different grades, testing for internal defects to the appropriate level in EN 10160 (Ref 10) and the requirements for the manufacturer's inspection certificate in accordance with EN 10204 (Ref 11).

When material is procured from a reputable manufacturer, so long as it is ordered correctly, all these matters will be available for checking. If however, a request is made to use material

from a stockholder or unknown or non-approved source, it will be necessary to require inspection, testing and certification in accordance with the Standard. Certificates of Conformity seldom contain much, if any, of the detailed information that should be available.

### References

1. EN 1993-2: 2006, Eurocode 3: Design of steel structures – Part 2: Steel Bridges
2. EN 1090-2: 2008, Execution of steel structures and aluminium structures - Part 2: Technical requirements for steel structures.
3. EN 10025: 2004, Hot rolled products of structural steels.  
Part 1: General technical delivery conditions.  
Part 2: Technical delivery conditions for non-alloy structural steels.  
Part 3: Technical delivery conditions for normalized/normalized rolled weldable fine grain structural steels.  
Part 4: Technical delivery conditions for thermomechanical rolled weldable fine grain structural steels.  
Part 5: Technical delivery conditions for structural steels with improved atmospheric corrosion resistance.  
Part 6: Technical delivery conditions for flat products of high yield strength structural steels in the quenched and tempered condition
4. EN 10210-1:1994, Hot finished structural hollow sections of non-alloy and fine grain structural steels. Part 1: Technical delivery requirements.
5. EN 10219: 2006, Cold formed welded structural sections of non-alloy and fine grain steels. Part 1: Technical delivery requirements.
6. EN 10164: 2004, Steel products with improved deformation properties perpendicular to the surface of the product. Technical delivery conditions.
7. Model project specification for the execution of steelwork in bridge structures (P382), SCI, 2009.
8. EN 10029:1991, Specification for Tolerances on dimensions, shape and mass for hot rolled steel plates 3 mm thick or above..
9. EN 10163, Delivery requirements for surface conditions of hot-rolled steel plates, wide flats and sections (Parts 1 to 3, 2004)

10. EN 10160: 1999, Ultrasonic testing of steel flat plate product of thickness equal to or greater than 6 mm (reflection method).
11. EN 10204: 2004, Metallic products. Types of inspection documents.



## Drawings and execution specification

## No. 4.01

**Scope**

This Guidance Note explains the differences between contract drawings (usually produced by the designer) and working or fabrication drawings. The issue of approval of fabrication drawings is discussed. The definition of 'execution specification' given in EN 1090-2 is discussed.

**General**

Drawings are a necessary part of the documentation needed to explain how a structure is to be built (or, in the case of record drawings, how it has been built). Indeed, drawings are referred to in the Conditions of Contract and are part of the execution specification. But drawings are needed for more than one purpose and will be made by more than one party to the contract.

**Designer's drawings**

The designer (the Engineer, in traditional forms of contract) must specify clearly and unambiguously what is to be built; he is responsible for ensuring that this is of adequate strength and stability both during service and during construction. The latter requirement has in the past been subject to some tendency to pass responsibility to the contractor (for example, statements such as "all bracing necessary for erection purposes to be designed by the Contractor" appeared on designer's drawings) but with the advent of the CDM Regulations the responsibility for showing how his structure can be built safely is confirmed.

The Designer's/Engineer's drawings thus form definitive documents describing the structure. Provided that the structure is built in accordance with the drawings, and the associated technical requirements, the responsibility for the design remains with the designer. Further, the work of the constructor is clearly defined.

In summary, the designer needs to communicate the following information:

- The dimensions required on completion.
- The materials and sizes needed.
- Assumptions made by the designer about the construction sequence.
- Information about the presumed behaviour of the structure (see GN 4.03 on allowance for permanent deformations).

Most of this information is best transmitted in the form of drawings. With the increasing use of computerised data, drawings can now be transmitted electronically in many cases.

**Steelwork contractor's drawings**

When considering the work of the constructor, it should be remembered that the steelwork contractor (fabricator) is usually a subcontractor, so that there are at least two parties involved. The steelwork contractor should provide details about the work that he will carry out.

The steelwork contractor needs to determine additional information so that his operatives can fabricate the steelwork. Typically, dimensions need to be adjusted to allow for shrinkage as a result of welding, and the welding procedures to be used must be selected. Sometimes temporary attachments to the steelwork are needed, either for fabrication purposes or for those of the erector on site. The method of presenting this information is not always the same, and some of the information, where it might effect the integrity of the design, will need to be considered by the designer.

In the past, dimensional information was presented in the form of full-scale wooden templates, made by skilled craftsmen in the 'template loft' of the fabricator's works. Pieces were thin ply, cut size-for-size. There were few fully dimensioned drawings.

With the introduction of more modern cutting machines, templates were abandoned in favour of a comprehensive set of detailed and fully dimensioned fabricator's drawings (on paper). This arrangement has, until fairly recently, been considered the norm: designers were usually provided with a set of the steelwork contractor's drawings and they often checked the accuracy of dimensions derived from the contract drawings.

Now, with the increasing use of computer-controlled machinery, the need for printed drawings to convey the dimensional information is disappearing. With all information held and transmitted electronically, there is little need for anything more than simple illustrative sketches for identification purposes. Additionally, computer modelling offers an integrated database of all dimensional information that greatly reduces

# Guidance Note

## No. 4.01

---

the errors arising from the transfer of dimensions from one drawing to the next (this is particularly a risk when details are updated), although errors will still be perpetuated if there is inaccurate input data.

However, the need to communicate to the designer matters which might affect the design of the permanent works must still be remembered. Such information has to be presented to the designer for his approval. See further comment below about approval.

The information that needs to be communicated to the designer includes:

- where the steelwork contractor proposes to weld attachments to the steelwork,
- where the steelwork contractor proposes an alternative erection scheme which implies different materials or sizes,
- details of cutting and welding the steelwork,
- any variations that are proposed, either to suit fabrication in the contractor's works or to suit the chosen erection scheme, such as extra butt welds or relocated joints.

Most of this information does not necessarily need new drawings, although the steelwork contractor may choose to produce drawings for these purposes.

### **Approval of working and fabrication drawings**

It is a requirement of the SHW (Ref 1) that, where listed in the Appendix 1/4 to the project specification, working and fabrication drawings be submitted for approval. However, this is a requirement that is not covered by the traditional form of contract (ICE Conditions, 5th or 6th editions). There the Engineer's approval of drawings etc. is required only where part of the permanent works is expressly required to be designed by the contractor. In this form of contract the "Drawings" that form part of the contract are those issued by the Engineer or "any modification of such drawings approved in writing by the Engineer".

It would therefore seem that the approval of working and fabrication drawings required by the SHW should only relate to matters that affect the design of the permanent works. Any representation of information already on the contract drawings does not need approval; any di-

mensional interpretation of information on the contract drawings requires only consent (the contractor is responsible for the setting out of the works and this responsibility is not relieved by any consent or even 'approval'). If the steelwork contractor does not require 'drawings' to transmit information to his operatives, there seems to be no contractual reason to require such drawings. Therefore, the designer should be frugal in listing what working drawings he requires and should not expect drawings where they would not exist.

It is understood that the question of approval has been a cause of concern for some designers, who have been advised by their insurers only to consent to details on steelwork contractor's drawings. Whilst the majority of such information does only require consent, the duty of the Engineer is to approve matters that modify the permanent works: a response of suitably limited approval should be given.

Design and build contracts operate under different contractual arrangements and the question of 'approval' is not the same. Nevertheless, there will still be some demarcation between the responsibility of the designer and of the steelwork contractor that must be recognised.

### **Use of drawings for inspection**

Such drawings as will be needed by an inspector acting on behalf of the Engineer or a client should be sufficiently provided by the set of contract drawings. The inspector has to check that workmanship and final dimensions comply with the specification and contract drawings. It should not be necessary to make use of the steelwork contractor's drawings (such as exist), except possibly those giving marking plans, etc.

### **Record drawings**

The designer's drawings, suitably updated to include any approved changes by the steelwork contractor, should be sufficient for record purposes in most cases. However, sometimes the client requires a fuller record, perhaps including details of identification marks on each component, location of temporary attachments that were later removed, etc. In such a case the requirement should be clearly stated in the project specification and an item included in the BoQ; the contractor and steelwork contractor can then allow for the cost of producing such drawings.

### **Execution specification**

The term 'execution specification' is defined in EN 1090-2 (Ref 3) as:

"[the] set of documents covering technical data and requirements for a particular steel structure including those specified to supplement and qualify the rules of this European Standard".

The execution specification thus comprises the totality of the documents that the steelwork contractor needs to specify for the work to be carried out. It therefore includes both the designer's and the steelwork contractor's drawings, the project specification, EN 1090-2 and all referenced standards, together with the steelwork contractor's own work instructions.

For preparation of a project specification, the designer will normally use the Model Project Specification (Ref 4), modifying and completing it as necessary for the project.

### **References**

1. Specification for Highway Works Series 100 and NG100, TSO.
2. BD 62/07, As-built operational and maintenance records for highway structures, TSO, 2007
3. EN 1090-2:2008, Execution of steel structures and aluminium structures. Technical requirements for steel structures.
4. Steel Bridge Group: Model project specification for the execution of steelwork in bridges (P382), SCI, 2009.



### Scope

This note is intended to give the reader an insight into the fundamental principles involved in the formulation, testing and qualification of weld procedures.

What used to be referred to as weld procedure trials (now called tests) are expensive and time consuming. Even on a small structure there can be a large number of combinations of variables. It was therefore usual to make reference to previously approved trials, and for those trials to have been conducted in such a way that a range of weld procedure specifications (WPS) for production could be derived from them.

### Requirements

EN 1090-2 clause 7 specifies all welding requirements.

Clause 7.1 requires that welding shall be undertaken in accordance with the requirements of the relevant part of EN ISO 3834 (fusion welding) or EN ISO 14554 (resistance welding) as applicable. It further requires, among other things, that arc welding of ferritic steels should follow the requirements and recommendations of the relevant parts of EN 1011

Clause 7.4.1 covers the qualification of welding procedures.

Sub-clause 7.4.1.1 requires that welding shall be carried out with qualified procedures using a welding procedure specification (WPS) in accordance with the relevant parts of standards covering, among other things, arc and resistance welding by various welding processes.

Sub-clause 7.4.1.2 for processes 111, 114, 12, 13 and 14, covers most of the processes likely to be used for steel bridgework fabrication. Sub-clause 7.4.1.3 covers processes including 783 and 784 for resistance welding, which would include those for shear stud welding. These sub-clauses refer to Tables 12 and 13, respectively, which list the methods of qualification and the applicable standards for different Execution Classes under EN 1090-2.

The three standards relevant to this Guidance Note are:

EN ISO 15614-1 for Welding Procedure Test using a standardised test piece;  
EN ISO 15613 for Pre-production Welding Test using a non-standard test piece representative of the production conditions, and,  
EN ISO 14555 for stud welding.

All these methods are applicable to EXC3 (the steel bridge default execution class in the MPS, Ref 10) and EXC4 where it is called for.

### Terminology

EN ISO 15607, Specification and qualification of welding procedures for metallic materials – General rules describes the sequence of testing and approval which is laid out in three normative Annexes A, B and C.

Having considered the technical and practical requirements of a proposed welded joint or range of welded joints, the welding engineer will formulate a preliminary Weld Procedure Specification (pWPS).

Based on the pWPS, weld procedure tests will then be carried out in accordance with EN ISO 15614 for a standardised test piece or EN ISO 15613 for a non-standard test piece. If the results are satisfactory, a Welding Procedure Qualification Record (WPQR) will be prepared recording details of the weld procedure and test results.

From each WPQR a number of Weld Procedure Specifications (WPS) can be prepared, since a single WPQR approves a range of variables (see EN ISO 15614). All production work should be carried out in strict accordance with an appropriate WPS.

### **EN 1011-2:2001 – Recommendations for welding of metallic materials – Part 2: Arc welding of ferritic steels.**

This standard was developed from, and superseded, BS 5135 (This section of the Note is included to provide the historical background to the development of requirements for formal written weld procedures and the tests to qualify them.)



# Guidance Note

## No. 4.02

---

BS 5135 contained references to the standards covering the manufacture of various types of welding consumables together with the requirements for their satisfactory storage.

There were also general clauses setting basic workmanship requirements for the execution of welds. However the main body of the text related to the development of weld procedures for the avoidance of cracking.

Three categories of cracking are cited:

- Hydrogen induced delayed cold cracking
- Solidification cracking
- Lamellar tearing

BS 5135 was first published in 1974, and in that version all of the above issues were covered in terms of guidance notes given in the appendices rather than expressed requirements.

The 1984 revision changed the situation, with the provisions for the control of hydrogen induced delayed cracking becoming expressed requirements of the standard.

The measures for the avoidance of solidification cracking and lamellar tearing remained only as recommendations in the appendices.

Regarding the mechanical properties of the welded joint, BS 5135 stated that these were to be as required by the application standard, but gave no guidance on how this might be achieved.

In formulating a pWPS for a particular joint or family of joints, the welding engineer had therefore to follow the expressed requirements of BS 5135 in respect of hydrogen induced delayed cold cracking, but then rely on professional judgement regarding the attainment of the necessary mechanical properties and the avoidance of solidification cracking and lamellar tearing.

In addition a competent welding engineer had to consider measures for distortion limitation.

### **The requirements of EN 1011-1 and –2.**

With respect to the welding of ferritic steels these Standards aim to cover all the aspects of welding technology previously covered by BS 5135. However, they seek to achieve this aim by setting down general guidance in Part 1 and more specific guidance in Part 2. It should be noted that both parts are titled “Recommendations”, not “Specifications” or “Requirements”. As such there is a much greater reliance on the competence, technical qualification and experience, and judgement of those using these standards than was the case when BS 5135 was invoked.

This Guidance Note is limited to the subject of standard and pre-production welding tests. There are many other cross-references in the latest EN and ISO standards, which should be consulted where necessary.

In the UK, for steel bridgework for highways and railways, the use of EN 1090-2 leads (through the standards invoked in 7.4.1.1) to the requirement for the provision and use of written weld procedures. EN 1011-1 requires that the preparation of a weld procedure specification (WPS) shall be in accordance with EN ISO 15609. For arc welding, EN ISO 15609-1 applies and the technical content requirements of the WPS are covered by clause 4 of this Standard. An (informative) example is given in Annex A of the Standard.

### **Welding tests**

The welding tests are carried out on standardised test pieces as specified in EN ISO 15614, clause 6.

The test pieces are required to represent, rather than totally replicate the joints to be welded in production. Their configurations are standardised to ensure that the necessary test specimens can be obtained.

A competent welding engineer will carefully select the features of each weld procedure test so that, if possible, the resulting Weld Procedure Qualification Records (WPQRs) will approve the full range of joints to be encountered in the production work, with the minimum number of tests.

It is usual for the formal welding tests to be witnessed by an examiner from an independent examining body. The witness countersigns and stamps the WPQR certificate.

As well as destructive testing of samples taken from the test pieces, non-destructive testing of the test piece to an acceptance level of class B of EN ISO 5817 is required (although level C applies to visual imperfection types: excess weld metal, excess convexity, excess throat thickness and excessive penetration).

The extent of non-destructive and destructive testing is set out in clause 7 of EN ISO 15614. Figure 1 of this note shows examples of the test pieces required to qualify a butt weld.

### **Weld Procedure Qualification Record (WPQR)**

The WPQR is the formal record of a satisfactory weld procedure test. It records all the parameters for the test and the test results. It is certified by the examiner/ examining body that witnessed the tests and carried out the necessary mechanical tests and visual inspection.

Since the parameters for any test are variables, the WPQR certifies a range of values for which the test is considered to be valid. (For details about qualification ranges, see EN ISO 15614-1, clause 8.) This allows a number of Weld Procedure Specifications to be prepared from a single welding test.

Specialist bridge fabricators usually hold a large library of WPQRs. Provided that the records are properly witnessed by an examiner/ examining body, they will form a satisfactory basis for the development of the specific WPSs necessary to carry out the production work, with only occasional need for a supplementary weld procedure test.

If there is any doubt regarding the authenticity of an existing WPQR, then fresh welding tests should be carried out.

### **Weld Procedure Specifications**

The review of relevant WPQRs and the preparation of WPSs for production work is a

complex matter and should always be carried out by a qualified welding engineer.

It must be remembered that a WPS is valid for production welding only when all the parameters are within the limits of validity of the various items of recorded data in the WPQR.

Any changes in welding process, consumable designation, and type of welding current, always require the establishment of a new pWPS and procedure qualification test.

### *Fabricator's equipment and operatives*

It is prudent to ensure that the welding equipment used in production is properly calibrated and maintained and appropriate to the WPQR, and to check that welders' qualifications are relevant to the WPS and up to date.

The new EN standards require that, subject to specific conditions, the welder's approval certificate be signed at 6-monthly intervals by the employer's authorised signatory. Should the employer wish to prolong a welder's approval beyond two years, records of volumetric inspection and tests must be maintained and attached to the welder's approval certificate for verification by the examiner/ examining body. This can be a problem for a fabricator undertaking a wide range of bridgework - some procedures and equipment may not have been used for some time.

### **Application tests/trials**

The contractual requirements are set out above. The Client cannot demand more unless it is clearly specified and/or allowed for in the Contract. Sometimes, however, while the WPQRs and the particular WPSs may seem to cover the essential features of all the joints in the work, some applications may be constrained in some way, e.g. lack of clear access or by one type of joint leading into another. In such circumstances, it may be prudent to specify (and pay for) extra welding tests, called Pre-production tests. These trials are covered by EN ISO 15613 which is used as a basis for qualifying any project specific pre-production tests necessary. It has been found worthwhile to call for

# Guidance Note

## No. 4.02

---

them in particularly difficult circumstances, to ensure that the welds can be completed properly. The trials are carried out on purpose-made, non-standard test pieces that truly represent the application. The testing of such pieces can be limited to visual and dimensional inspection, i.e. a demonstration that the welding of the joint can be performed physically. However, sectioning and the preparation of macro specimens and hardness testing of the weld and HAZ are also further confirmation of the quality of the weldment. Depending on the complexity of the test piece it may be possible to devise non-destructive examination techniques for checking production work. Finally, the test specimens are also useful as comparative visual reference pieces for the workshop inspectorate during the performance of the work.

### References

1. EN 1090-2 2008 – Execution of steel structures and aluminium structures – Part 2: Technical requirements for steel structures.
2. EN 1011-1: 2009, Welding. Recommendations for welding of metallic materials. General guidance for arc welding.
3. EN 1011-2: 2001, Welding. Recommendations for welding of metallic materials. Arc welding of ferritic steels.
4. EN 288, Specification and approval of welding procedures for metallic materials  
Part 1: 1992, general rules for fusion welding. (Withdrawn)  
Part 2: 1992, Welding procedures specification for arc welding. (Withdrawn)  
Part 3: 1992, Welding procedure tests for the arc welding of steels. (Withdrawn)
5. EN ISO 5817: 2003, Welding. Fusion-welded joints in steel. Guidance on quality, nickel, titanium and their alloys (beam welding excluded). Quality levels for imperfections.
6. EN ISO 15607: 2003, Specification and qualification of welding procedures for metallic materials. General rules.
7. EN ISO 15609-1: 2004, Specification and qualification of welding procedures for metallic materials. Welding procedure specification. Arc welding
8. EN ISO 15613: 2004, Specification and qualification of welding procedures for metallic materials. Qualification based on pre-production welding test..
9. EN ISO 15614-1: 2004 + A1:2008, Specification and qualification of welding procedures for metallic materials. Welding procedure test. Arc and gas welding of steels and arc welding of nickel and nickel alloys.
10. Steel Bridge Group: Model project specification for the execution of steelwork in bridges (P382), SCI, 2009.

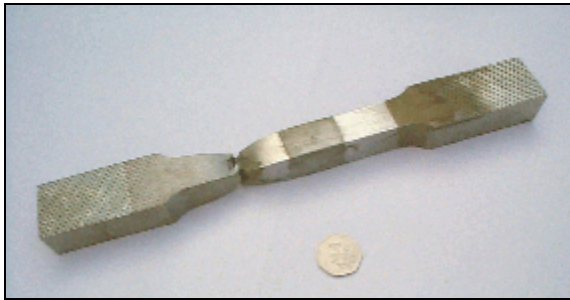

Tensile test piece

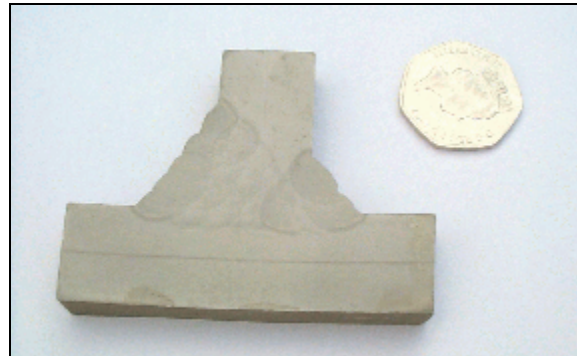

Butt weld macro



Bend test (note opening of root defect)

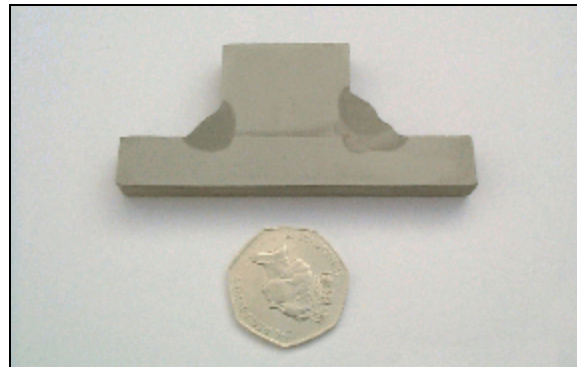

Fillet weld macro

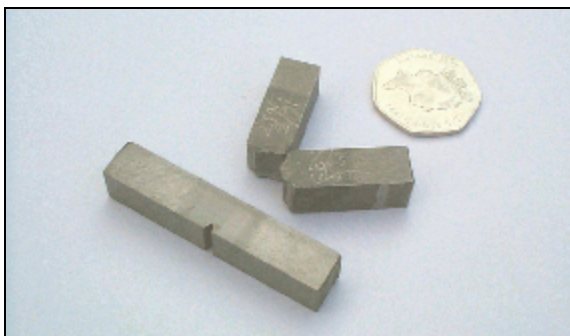

Charpy impact test pieces

**Figure 1** *Examples of test specimens*



## Allowing for permanent deformations

## No. 4.03

**Scope**

This Guidance Note gives information about the determination of allowances for permanent deformation (chiefly, the vertical deflection of the main girders). These deformations arise as a result of the shrinkage or distortion during fabrication, the self-weight of the construction works (weight of steel structure, concrete deck, surfacing, etc.) and the shrinkage effects of the reinforced concrete deck slab.

For additional considerations in skew bridges, see GN 1.02 and GN 7.03.

**Bridge profile**

The required final vertical profile of a bridge is determined by the requirements for the profile of the highway or railway which is carried on it, and on any clearance gauge above or below that needs to be observed. The actual profile on completion depends on the cut shapes of the steelwork components; these depend on allowances for 'dead load' deflections, on the actual distribution of the loads, on the actual behaviour of the structure and on the accuracy to which the structure can be built.

The designer specifies the required profile of the bridge (longitudinally and transversely) on completion (see further comment below on required final profile). He chooses the structural configuration of the bridge and analyses its behaviour for an assumed construction sequence and in service. He is therefore well placed to be able to give the constructor information about the expected behaviour. (The CDM Regulations (Ref 1) can be interpreted as requiring him to do so, although this has not been tested in the courts.)

Construction of a steel (non-composite) bridge involves only one major structural element, the steelwork. The behaviour of the steelwork under load, even for a statically indeterminate structure, is predictable to a reasonable degree of accuracy, the main uncertainties being relaxation due to relief of residual stresses (sometimes called shake-out) and in the alignment or fit-up of connections.

Construction of a composite bridge involves two major structural elements, the steelwork and the reinforced concrete deck. As before, the behaviour of the bare steelwork is reasonably predictable, but the behaviour of the

composite structure is less predictable on several counts. The first is that all the concrete cannot be placed in an instant, and the stiffness that is gradually acquired by the first-placed concrete modifies the structural behaviour as later concrete is placed. Also, concrete in tension does exhibit some stiffening effect, and the usual allowances for cracked regions can only be approximate. Further, the stiffness of the concrete varies with age and strength and cannot be predetermined with the same reliability as that for steel.

For a composite bridge, the fabricator manufactures the steel girders, the erector lifts and connects the steelwork together, the concreting contractor places the concrete, and another contractor places the surfacing or ballast. When should the profile of the bridge be checked, to which theoretical profile, and whose 'fault' is it when the profile is not exactly as intended (i.e. within tolerance)?

**Provision of deflection allowances**

The designer should provide the contractor with information about the difference between the profile of the prefabricated elements (when not subjected to any applied loads including self weight) and the intended final profile once the structure has been completed. These differences are the calculated vertical deflections for the assumed method of construction, for the presumed behaviour of the structure.

These allowances for permanent deformation are usually shown on the steelwork general arrangement drawing in a diagrammatic form.

This information is sometimes called 'camber' or 'camber allowance' or 'pre-camber', but see comment below on terminology.

In addition, for a composite bridge the designer should provide calculated differences from the unloaded profiles of the elements for the stage when all the steelwork has been erected (the 'bare steel' condition). This set of differences will allow the fabricated and erected profiles of the steelwork to be checked (and agreed as acceptable) both on despatch from the workshop and after erection, before the concrete is added. *Once the concrete has been added there is usually very little that can be done to correct any errors in the profile of the steelwork.*

### **Accuracy of allowances for deflection**

How should the designer estimate the deflection during construction and what should be done about any deviation from the intended profile at the end of construction?

The deflection of bare steelwork under load is predictable, but it is important to remember that when there is any degree of indeterminacy (even if only due to secondary bracing or secondary bending effects in nominally 'pinned' connections) the deflections will depend on the actual construction sequence.

In a composite bridge, the designer generally assumes that each stage of placing concrete is instantaneous, and calculates deflection due to dead and superimposed loads using the long-term modulus of the concrete. This usually results in an overestimate of the deflection that will have occurred at the end of construction. Since the greatest deflections occur in midspan regions, the as-built profile will be higher (in relation to the intended profile) at midspan than at the supports.

If considered necessary to 'correct' for any error in as-built profile, regulation (over-thick surfacing or additional bottom ballast) could be applied over the supports, with little consequences on moments or shears or indeed on reactions and foundation loadings. But if the as-built profile is low, adding regulation in midspan may not be structurally acceptable because of the significantly increased moments at the supports.

### **Allowances made by the fabricator**

Fabrication allowances are made by the fabricator appropriate to the welding and cutting processes to be used and the sequence of fabrication. These are the only allowances that are within the control of the fabricator.

Shrinkage during welding is the main source of permanent deformation during fabrication, but any treatment involving heat (such as cutting) can lead to deformations. Residual stresses, either due to rolling or to earlier stages of fabrication, may be relieved by heat, or by 'shakeout'; the fabricator will make allowances for all these effects.

### **Rectification of errors in fabrication**

Steel is not totally predictable in its behaviour when heated, as this releases locked-in stresses that are due to the manufacturing process. Some differences between expected and actual fabricated shape have to be tolerated, but these should be small.

Any significant errors in the shape or size of components that arise during fabrication can be corrected before erection, provided that they can be identified (see GN 5.07). The additional information about deflection of steelwork (of a composite bridge) in the 'bare steel' condition referred to above will allow a useful check either during trial assembly (if specified in accordance with EN 1090-2 clause 6.10) or after erection of the (bare) steelwork.

### **Rectification of errors in profile**

Contractually, the achievement of the required final profile is the responsibility of the Main Contractor. However, the designer has had some input to the result (allowances for dead load deflections, based on an assumed construction sequence). Any failure of the structure to respond exactly as predicted, particularly for a composite bridge, cannot be held to be the 'fault' of the fabricator, nor is it likely to be that of the contractor placing the concrete (provided that the sequence assumed by the designer is followed and all the concrete in any stage is placed within a reasonable period). The designer and contractor need to cooperate in reaching solutions to deviations that appear during the course of construction.

The responsibility for providing any necessary regulation can be placed on the contractor, who can make allowances (in his tender) for the amount of regulation likely to be needed, on the basis of his experience and of the deflections predicted by the designer. The consequences on programme should then be allowed for by the contractor but, if considered necessary, an additional clause could be added to the item coverage in the BoQ Preambles.

### **Tolerances**

It is difficult to apply any tolerances to the confirmation of the correct profile of the steelwork once concrete and surfacing or ballast has been placed. Hence, there is a need for the designer to provide deflection information for the steelwork alone, to facilitate checks

and agreement that is complied with at the trial erection stage or at the bare steel after erection stage. EN 1090 clause 9.6.4 deals with trial erection and, while it only suggests consideration of trial erection for reasons other than proving the as-built profile, reference should be made to Annex D.2.15 *Functional erection tolerances – Bridges – Bridge elevation or plan profile*, for the permitted deviation from the nominal profile.

### Terminology

As explained above, the vertical shaping of steel bridge girders depends on three components:

- (1) The specified 'required final profile' of the finished bridge, usually following a vertical curve longitudinally (see comment below).
- (2) Allowances to counteract deflections of the structure under the dead loads of the steelwork, deck concrete, surfacing or ballast, and finishes.
- (3) Allowances to counteract fabrication effects.

These components are shown schematically in Figure 1.

The terms "camber" and "pre-camber" are often used in relation to the profile of a girder, but they are not always used in the same sense, nor do all parties necessarily agree which of the above three components should be included in them.

The term "residual camber" is also sometimes used, but is also best avoided in composite bridges.

Most references to "camber", are made in the sense of an allowance above a clearance gauge or to avoid unsatisfactory appearance, i.e. functionality. It does not necessarily imply a simple vertical curve profile (which may in any case be provided for other reasons) nor just an allowance for dead load deflections. The use of "camber" in this sense is best avoided.

Camber (or pre-camber) is often implied by designers to mean their calculated allowances for deflection (2 above), but sometimes the designer means the deflections plus the offset from a straight line between supports (i.e. 1+2 above). Fabricators usually consider camber as the sum of the two allowances (i.e. 2+3 above).

EN 1090-2 Annex D, Table D.2.15 No.2, covers bridge elevation or plan profile but seems to mean curvature generally: it does not specifically identify any one (or combination) of the above items, nor does it make it clear at what stage the checking is performed.

The reference points and locations for erection tolerances are specified in accordance with EN 1090-2 clauses 12.7.3.3 and 12.7.3.4. The MPS provides clauses for further definition of location and frequency of measurements (Ref 3).

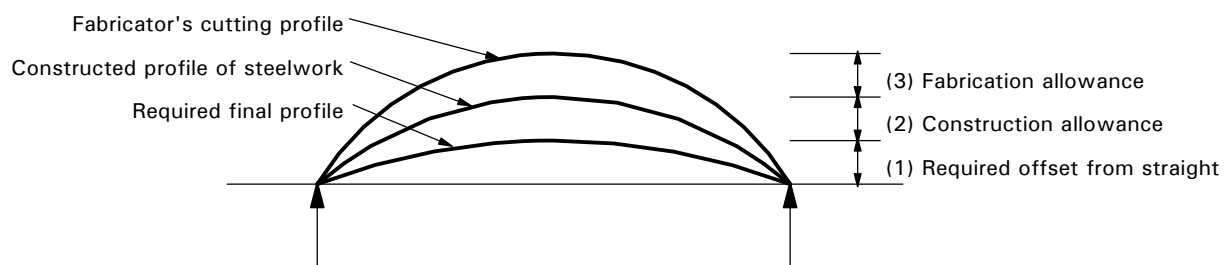

**Figure 1** Schematic illustration of shaping of steel girders

Notes:

- 1 The required final profile is usually determined by the highway or railway engineer; this may or may not be a vertical curve.
- 2 The construction allowance is calculated by the designer to allow for self-weight deflection, prestress, shrinkage of concrete, etc. For a simple span this allowance will be an upward curvature, as illustrated.
- 3 The fabrication allowance is determined by the fabricator to allow for shape changes due to thermal cutting and welding, and due to shake-out of residual stresses during fabrication, transport and erection. It may be in either direction, upward or downward, depending on the fabrication details; an upward allowance is illustrated, for simplicity.



# Guidance Note

## No. 4.03

---

However the dimensional information is presented, and however it is referred to, it should be made clear exactly what is meant and which of the three components is included in the values. The word “camber” may be used on drawings and in documents, but it should be used with care and with a clear definition of what it means

### **Required final profile**

(Although the specification of profile is not the subject of this Note, the following comments may be helpful.)

The required profile of the carriageway surface of a road bridge is normally a positive (upward) vertical curve. This profile is to be achieved under the effects of (Serviceability Limit State) dead and superimposed dead loads, without any live load. If the road surface requires no vertical curvature and is level, there may nevertheless be a requirement for a small upward curvature of the structure to ensure that a clearance gauge is maintained under SLS loads, or that the bridge does not appear to sag under the effects of live load

The required profile of a rail track is normally straight in elevation (or at least with only a very large curvature). Rail authorities normally specify that a rail bridge should not appear to sag under the effects of (SLS) dead plus live loads and they therefore also specify a positive vertical curvature as the required final profile over the length of the bridge.

For further comment about the specification of vertical curve profiles in skew bridges, see GN 1.02.

### **References**

1. Managing health and safety in construction, CDM Regulations 2007, Approved Code of Practice. HSE Books 2007.
2. EN 1090-2: 2008, Execution of steel structures and aluminium structures. Technical requirements for steel structures.
3. Steel Bridge Group: Model project specification for the execution of steelwork in bridges (P382), SCI, 2009.

## Consideration of alternative construction methods and sequences

No. 4.04

### Scope

This Guidance Note outlines the reasons for proposing an alternative construction method or sequence (alternative to that anticipated by the designer) and the key considerations in deciding whether a proposal should be accepted.

The consideration of alternative designs (for example a steel composite deck instead of a prestressed concrete deck, or 3 long spans instead of 5 shorter spans), is outside the scope of this Guidance Note.

### The designer's construction method

For many bridges it would be ideal if the design of the bridge for function and the design of how it is to be built were undertaken together. Whilst this is possible with the Design & Build type procurement process, it is precluded by the traditional procurement process where the Client employs a Designer to prepare a design in advance of tender. Here the Designer has to anticipate the most cost effective construction method – a method that, in the event, may or may not be used.

The Designer carries the entire responsibility for the permanent works design, and as such he anticipates the construction method in order:

- to ensure that the effects on the completed bridge of at least one construction method are correctly quantified
- to satisfy himself that the design can be built safely in a practicable way, to fulfil his obligations under Health and Safety legislation (including CDM Regulations)

The Designer should describe the anticipated method and related design assumptions in the contract documents. The information given should include:

- a diagram of the construction sequence
- information from the risk assessment
- information concerning the stability of the steelwork during construction (bracing requirements, limits on loading, etc.)

However, it is not the designer's responsibility to prescribe the construction method that must be used. While it is good practice to choose a method/sequence that is less likely to preclude alternatives, when choosing a method, advice should be sought from fabricators or erectors.

### The constructor's alternatives

A contractor (or a steelwork contractor working as a sub-contractor to the main contractor) may propose a different method or sequence of construction for a bridge from the method anticipated by the designer of the bridge in the design phase. In some instances, the Client may actively encourage tenderers to do this, with a view to obtaining best value.

An **alternative construction method** is when the bridge retains the same structural arrangement or one very similar to the original design, but the bridge is built in a different way to that envisaged by the designer. For example the original design may show erection of the steelwork by launching from one abutment whereas the contractor may prefer to erect the girders by crane.

An **alternative construction sequence** is where the bridge is the same as or very similar to the original design, but components of the bridge are constructed in a different sequence to that envisaged by the designer. For example the contractor may wish to concrete the deck slab of a composite deck all at once rather than in stages.

When a different construction method or sequence is used, the design assumptions may be invalidated, and the design must be revisited.

### The Client's requirements

The main consideration for the Client is to achieve value for money in securing his project objectives. He will require overall economy with the minimum risk to health and safety, and the minimum environmental impact whilst meeting aesthetic criteria and planning constraints.

# Guidance Note

## No. 4.04

---

The Client will normally identify in the instructions to tenderers his particular requirements regarding alternative construction methods including among other things:

- whether tenderers are permitted to submit alternative designs
- qualifications relating to the submission of alternative construction methods
- planning constraints and any need for further approvals
- aesthetic requirements (e.g. CABE approval)
- environmental constraints (e.g. temporary piers in rivers)
- Approval in Principle procedures
- requirements for independent checking.

None of the above would normally be expected to constrain a proposal for an alternative construction sequence, although in some instances changes in stress levels arising from the changed sequence will require further independent checking.

### **Reasons for alternative proposals**

Competitive tendering challenges contractors to use their expertise and ingenuity to devise how to build the bridge most economically, yet profitably. The choice of construction method is fundamental to a successful bid, so it is important that the tenderers are not inhibited unnecessarily in proposing alternatives that make best use of their expertise and resources

Following award of contract, there are many factors that can change sufficiently to require change of method for reasons of practicability, safety, or environmental impact, as well as cost.

On occasion, a design will prove to be deficient when the details of the erection are worked up by the contractor. In such cases the contractor will need to propose modifications which demonstrate that the bridge can be built.

### **Evaluation of an alternative proposal**

There can be very good grounds for using a construction method differing from that

anticipated in the design of the permanent works, so it is important that the final choice is discussed by the parties on the basis of the technical and economic merits of the options, and comparative risks to safety and environment.

A change of construction method that affects the original design of the permanent works will almost always require the Designer to do more work, perhaps under severe time constraints. In addition there may be an Independent Checker also having to do more work. These are matters that the Client and Designer should anticipate in preparing for and managing the procurement process.

Extra costs incurred for additional design work and/or checking by the Designer (and Checker) are a commercial issue for the Client. Where costs are incurred during the tender period this would normally be allowed for in the agreement between the Designer and the Client. If a change of method after award requires the design to be revisited then, the cost would normally be dealt with under the terms of the contract. Often the Contractor is required to meet this cost as part of the overall cost of the alternative proposal.

### **Responsibilities**

The Contractor is responsible for how the bridge is built, for the design of the temporary works, and for satisfying himself and the Designer that the effects of construction on the permanent works are not detrimental.

An alternative construction method or sequence may involve some modification to the design: change of precamber, alterations to stiffeners, additional stiffeners, repositioning of splices, changes to bracing and changes in plate sizes are all possible outcomes. It is incumbent upon the Client to recognise that the acceptance of proposals for alternative construction methods or sequences will frequently result in such changes.

Depending on contractual arrangements, the Designer may be required to take full responsibility for the changes to the design so that they effectively becomes his own. Alterna-

tively, the Contractor may become the “Designer” and the original Designer the Checker. Whatever the arrangement, responsibilities should be clearly defined and understood by all parties.

### **Summary**

The building of a bridge requires the combined skills, expertise and resources of both the Designer and the Contractor. The engineering of the construction method is important to both, so decisions need to be made in a co-operative way that produces the best outcome, not necessarily the one that was first anticipated. The fact that the acceptance of an alternative method or sequence supplants the Designer’s method is not a reflection on the Designer, rather it signifies an appropriate application of the particular expertise and resources of the Contractor.



## Weld preparation

No. 5.01

**Scope**

This Guidance Note relates to all fusion faces of any elements specified by the designer to be joined by welding, i.e. those for fillet welds as well as butt welds, whether special preparation is required or not.

**Relevant clauses in the Standards**

The clauses relevant to joint preparation are:

EN 1011 (Ref.1)

Part1:

General: **8.2**

Part 2:

General: **8.1, 8.2, Annex B**

Tolerances: **8.2** (fillet welds)

Preparation: **10**

Assembly: **11.**

EN 1090-2 (Ref.2)

General: **7.5.1**

The latter Standard recommends the use of EN ISO 9692-1 and EN ISO 9692-2 (Ref.3), where there are many examples of joint preparations suitable for use in bridge fabrication. These Standards detail dimensions and ranges of application including recommended welding processes.

In addition, EN 1090-2, 7.5.1.1 also recommends reference to EN 1993-2 (Ref. 4), where there is specific guidance on structural detailing of steel bridge decks including tolerances.

**General**

The typical forms of weld preparation in EN ISO 9692 are likely to be satisfactory in most applications. Modifications may be necessary to suit the position of welding or to accommodate a difficult access weld. Furthermore, bridge fabricators have approved procedures with particular joint preparations that suit their processes and methods. The 'Introduction' sections of the Standards recognize this by stating that the examples given cannot be regarded as the only solutions for the selection of joint type.

Contract specifications are often written giving only the weld type, size and position, and requiring the fabricator to propose such details to the designer for approval.

EN ISO 15609-1 (Ref.5) is the current specification for the content of welding procedure

specifications. Included in the requirements common to all welding procedures is joint design, and it is necessary to prepare a sketch or make reference to standards which provide this information. Standards imply national documents, e.g. EN ISO 9692, or perhaps fabricator preferred details of joint types regularly used.

It is suggested that all welds in structural bridgework are sufficiently important to require detailed sketches and the requirement should be made clear in the contract documentation. However, see comment below about prequalified procedures.

**Variability of preparation**

Experience has shown that the consistency of the chosen preparation is as important to the performance of a satisfactory welded joint as the actual dimensions chosen in any application.

EN 1011-2 gives guidance on preparation, geometry (including tolerances), assembly, alignment of butt welds and fit-up of fillet welds. Certain of these parameters will fall into the category of "essential variables" for particular processes and applications. This implies that variation outside the permitted range of tolerance may have a significant effect on the performance of the fabrication and hence cannot be permitted.

The achievement of an intended penetration in fillet welds is of particular importance, especially if the fabricator offers a deep penetration process/procedure. The key design parameter is the weld throat dimension, although the weld size is usually specified by leg length in the UK. The effective throat depends on the weld size (leg length), the weld shape (i.e. the ratio of two leg lengths, ideally 1:1) and the penetration into the parent plates. The depth of penetration is not measurable externally and tight procedural control of the process is necessary to ensure success.

Penetration is governed by two main things, the process/ procedure and the root gap (sometimes referred to as the fit-up). EN 1011-2 clause 8.2 gives an absolute upper limit of 3 mm for root gaps in fillet welds, but that is after saying that the edges and surfaces

# Guidance Note

## No. 5.01

should be in **as close contact as possible**. It should also be noted that there is a limit for imperfection for quality levels in EN ISO 5817 (Ref.6). For EXC3, quality level B applies and there is a formula to calculate the permissible root gap up to a maximum of 2 mm for material thickness greater than 3 mm.

Both Standards suggest that consideration should be given to increasing the leg length to compensate for a large gap. EN 1090-2 Clause 7.5.8 provides a formula for calculating the increased fillet size necessary to compensate for root gaps based upon the gap and the weld throat thickness.

### Preparations for hollow sections

For structures using hollow sections, especially where they meet at an angle, there are potential difficulties achieving satisfactory preparations all around the perimeter. EN 1090-2 Annex E provides weld preparations suitable for executing branch and in-line joints in hollow sections by applying the principles of EN 9692-1 specifically to this type of joint.

Most fabricators develop their own details for dealing with the transitions. This is usually a combination of varying the preparation locally and turning the elements during welding.

### Backing flats

The general advice is that these should be avoided if at all possible, by rearranging the joint details to permit welding from both sides. Where this is not possible, a steel flat may be tacked onto one of the prepared ends, **in the root of the preparation**. In that position it can be examined for cracking prior to permanent welding; if a tack is intact it can be incorporated into the weld; if not, it should be completely ground out before it is welded over. Only qualified welders, working to a qualified procedure, should be used for the attachment of backing flats, and, because of the small weld size and higher heat sink, it is particularly important to observe the preheating requirements. Figure 1 shows typical plane and T butt weld applications using backing strips.

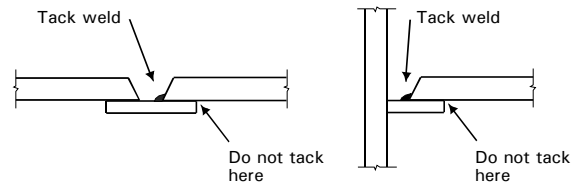

Note that the backing strip should fit as closely as possible to the plate surfaces and in any event with a gap of not more than 1 mm.

**Figure 1** Attachment of backing flats

Proprietary ceramic backing strips, either rigid or flexible, are widely available, and, if used correctly by experienced fabricators, can be an advantage for welding difficult joints. Procedure testing or application trials are recommended to confirm the joint integrity.

### References

1. EN 1011, Welding. Recommendations for welding of metallic materials.  
Part 1:2009, General guidance for arc welding.  
Part 2:2001, Arc welding of ferritic steels.
2. EN 1090-2:2008, Execution of steel structures and aluminium structures.  
Part 2: Technical requirements for steel structures
3. EN ISO 9692, Welding and allied processes. Joint preparation.  
Part 1:2003. Manual metal-arc welding, gas-shielded metal-arc welding, gas welding, TIG welding and beam welding of steels  
Part 2:1998, Submerged arc welding of steels.
4. EN 1993-2:2006. Eurocode 3- Design of steel structures- Part 2: Steel bridges.
5. EN ISO 15609-1:2004, Specification and qualification of welding procedures for metallic materials. Welding procedure specification. Arc welding.
6. EN ISO 5817:2007. Welding- Fusion-welded joints in steel, nickel, titanium and their alloys (beam welding excluded)- Quality levels for imperfections.

## Post-weld dressing

No. 5.02

**Scope**

This Guidance Note provides advice as to where and when post-weld dressing may be necessary. It applies to all routine welding made in the fabrication of steel bridgework and applies to the weld surface itself and the immediately adjacent platework (up to about 50 mm from the weld toe).

**Background**

Post-weld dressing is usually carried out by the fabricator in the workshop. It usually involves grinding of the weld and adjacent surfaces, and blending the weld into the parent metal on either side of the joint. It can be carried out by a disc or stone grinder, by a straight grinder with a tungsten-tipped cutter, or by continuous belt hand-held or trolley-mounted grinding machines.

**Relevant clauses in the Standards**

EN 1011 (Ref.1):

Part 1: **15; 17; 24; 25; 28; Annex A.2h)**

Part 2: **11; 14; 19.**

The above clauses state requirements either for post weld dressing to comply with the design specification or to facilitate appropriate inspection and testing.

**General**

The surface of a weld made in a correctly aligned joint, in accordance with an approved welding procedure, by a competent welder, should not need any post-weld dressing (except as noted in 5 below).

**Situations that may require post-weld dressing**

Post weld dressing may be necessary for a number of reasons, as given below.

1. To make good a misalignment at a butt weld.

Local unfused edges and/or out-of-tolerance steps in a butt-weld may be able to be made acceptable by local dressing.

If the extent of such misalignment is extensive (more than 10% of the length of the joint), it may be necessary to remake the weld (not preferred unless there is a critical design or aesthetic reason for doing so). Otherwise, it may be possible to build up locally by additional welding and dressing.

(This can lead to further distortions if not performed with great care).

2. To deal with small laminations adjacent to the weld.

Extensive, deeper laminations will have to be dealt with on their merits.

3. To remove weld spatter and/or the result of stray arc strikes on or adjacent to the weld.

4. To assist or permit the performance of non-destructive testing if the weld surface and/or fusion into the parent metal is uneven.

When undercut is within the permissible limits of the application standard, it may lead to spurious indications when Magnetic Particle or Dye Penetrant inspection is used in an attempt to detect surface-breaking defects.

5. To achieve and confirm a high fatigue classification of welds assumed in the design.

These high classifications are not usually used in the class of highway bridge work covered by the scope of the Guidance Notes, but in particular circumstances it may be appropriate to do so.

However, high classifications are needed in railway bridges, where, if post weld dressing is required, the final grinding should be done so as to leave the grinding marks in the direction of the principal stress, to avoid forming stress raisers.

6. To provide a flush surface where required for reasons of design, execution or appearance.

Examples are:

- fitting of other elements (the use of cope holes where welds intersect is no longer mandatory).
- flushing the bottom of the bottom flange of a girder when the bridge is erected by launching over rollers.
- flushing the top of the bottom flange butt welds of weathering steel girders to avoid ponding of water.



# Guidance Note

## No. 5.02

---

- flushing of a web butt weld in exposed faces of girders - this is not recommended as a general practice and often leaves a more obvious joint than the as-finished butt weld.
  - flushing of in-line joints in hollow sections, although it should be noted that in EN 1090-2 (Ref.2), this is not permitted on single sided butt welds executed without backing, unless otherwise specified.
7. To ensure that the remnants of temporary attachment welds are completely removed and that the area is free of defects.
  8. To assist in the effective cleaning, degreasing and other preparation for subsequent protective treatment.

In some instances, the smooth weld surface that results from particular welding processes, needs roughening to provide an adequate key for metal-sprayed coatings to adhere properly. In some such cases, even grit-blasting is not effective in this respect, and may be an indication of a faulty weld

procedure leading to an excessively hard weld surface.

9. To blend small local repairs of poor profile in long welds into the adjacent profile. Similarly, to blend crater cracked and/or poorly shaped stop-starts and to remove or blend out defects at the ends of any weld.

Apart from 5 and 6, the above reasons are considered normal requirements for the quality of workmanship specified for bridge steelwork. If a full penetration flush butt weld is required for reasons of strength, fatigue or appearance, this must be made clear on the drawings or in the project specification.

### References

1. EN 1011, Welding. Recommendations for welding of metallic materials  
Part 1: 1998, General guidance on arc welding  
Part 2: 2001, Arc welding of ferritic steels.
2. EN 1090-2:2008, Execution of steel structures and aluminium structures. Part 2: Technical requirements for steel structures

**Scope**

This Guidance Note presents a brief consideration of what can be expected in terms of the accuracy of a structure's fully assembled length, width and vertical profile. Reference is made to EN 1090-2 (Ref 1) and to the special tolerances given in the Model Project Specification (MPS) (Ref 2).

**Execution Standard**

EN 1090-2, Clause 11 defines three types of permitted geometrical deviations (tolerances):

- Essential tolerances, which relate to criteria that are necessary for mechanical resistance and stability, and which are used to support CE marking of components to EN 1090-1 [Ref 3];
- Functional tolerances, which relate to other criteria such as fit-up and appearance;
- Special tolerances, which may be specified for project-specific reasons and which need to be clearly defined in the execution specification.

The requirements relate to final acceptance testing and thus cover tolerances for both fabrication and erection.

At a cost, and given the time, very high levels of dimensional accuracy are possible, but the main issue is what can be justified for the particular structure.

The MPS provides values of special essential tolerances in its clause 11.201 and a means to set special functional tolerances in 11.301. The background to the values is explained below.

**Types of dimensional imperfection**

As with all manufactured items, fabricated components contain both random and systematic dimensional errors.

On larger structures, where many girders may be joined end-to-end, there will be a general tendency for the random errors to be self compensating: the statistical probability of all such errors accumulating in one sense will be very small. Systematic errors on the other hand, will generally accumulate.

The relationship between the magnitudes of random and systematic errors varies among fabricators, depending on their methods and their equipment, and will also vary with structural form.

In bridge construction, length is one of the most important dimensions that needs to be controlled. The overall dimensions of smaller structures, with few fabricated components in their length, will be influenced by both random and systematic errors; longer structures, with many components, will be influenced mainly by systematic errors.

Generally it can be expected that the ratio of total error to total dimension can be expected to be better on larger structures where there are more components and the random elements have a chance to cancel one another out, than on smaller structures with fewer elements where there is less chance of the random errors self compensating.

**Plan Position at Bearings**

The accuracy with which the steelwork can be positioned on the substructure is affected by the build-up of fabrication and erection deviations. Figure 1 shows typical longitudinal and transverse deviations in plan position at datum temperature between the various components, together with a brief commentary.

When considering the tolerance on movement capacity of a sliding bearing, a 10 mm allowance should be made for the sum of random deviations at the various interfaces shown in Figure 1 plus  $L/10000$  for the systematic deviation in girder length. This tolerance is given in the MPS, 11.201(iii).

*Adjustment of errors in length*

The accumulation of small systematic errors in the fabricated length of girders can sometimes make it necessary to adjust the length of the steelwork in order to meet the tolerances on plan position at the bearings.

On long-span bridges, adjustment may be achieved by match marking and trimming joints in rolling assemblies at ground level, taking account of as-built surveys of the

# Guidance Note

## No. 5.03

---

substructure. This approach is slow and expensive, but is essential for long structures (over about 250 m).

In viaduct work, adjustment points are normally pre-planned, and the main girder joints at those positions are not completed until dimensions are available from site indicating how the structure is matching the local bearing locations.

Such adjustments are assessed in relation to the substructure grid lines, which are themselves subject to tolerance, rather than being absolute overall dimensions. Given a good standard of fabrication and substructure set-out, such adjustment points would typically be at 150 m intervals.

Between adjustment points, errors accumulate. The amount of error that can be safely accommodated at each support position should consider the following:

- The allowable eccentricity in the support, which is a matter of design.
- The available spare movement capacity in sliding bearings, which is a matter of bearing selection and design.
- Any implications regarding expansion joint movements.
- The flexing of tall slender piers when fixed bearings are used

The selection of adjustment points in long structures should therefore be a matter of discussion and agreement between the designer, the main contractor and the fabricator, and should take place as early as possible in the project.

The assessment of misalignment at each support as construction proceeds needs careful observations, and should take into account average steel temperature together with any rotations and translations that will occur due to the action of self weight. The problems in assessing temperature effects are discussed in GN 7.02

As bearing locations may have to be adjusted, it is recommended that only fixed bearings be fully grouted prior to erection. Pockets for bearing fixing dowels should be

detailed to allow such adjustment of bearing base plates. Temporary bearing packing systems should be planned carefully in terms of capacity and disposition in order to safely support the steel self weight in all erection conditions

### **Structure width**

Errors in width will tend to be higher, relatively, than those in length. This is because there is usually a high number of joints (per unit width) and any dimensional errors tend to be dominated by systematic effects.

Bridges skewed in plan will tend to have greater relative error in width than those that are square in plan.

A general tolerance of width/1000 should be achievable. A tolerance of  $\pm 10$  mm on spacing of top flanges where permanent formwork is to be used is given in the MPS, 11.201(v).

### **Vertical profile of steelwork**

The weld shrinkages at the top and bottom flanges of bridge girders are often different, because of differences in weld size and flange cross section, and due to the sequence of welding. Such differentials give rise to a vertical curvature in the girder, and this may well be in the opposite direction to that of the vertical profile and the allowance for deformation due to permanent actions.

Fabricators use empirical rules to adjust the shape of the web to allow for such effects as shrinkage. This is not a precise science, and the control of the profile, particularly on slender girders, is a matter that requires experienced judgement by the fabricator.

To complicate the issue further, all 'as-welded' fabrications have locations adjacent to welds where residual stresses are at or about the yield point for the material (the forces are in equilibrium with other internal forces). Externally applied vibrations or loads can give rise to stress relief at these locations, and to a resultant overall change in shape of the fabrication as the equilibrium in internal forces changes. This effect is not significant in the majority of bridge girders, but can be an issue in structures where the

span to depth ratio is around 30 or more. Girders of such proportions have been known to alter in their profile during transportation.

For the above reasons, relative errors in profile tend to be greater in shorter spans. In longer spans, the girders tend to be inherently less slender, but also, since more individual girder pieces tend to make up the span and provide an opportunity for vertical rotational adjustment at each joint, considerably lower relative errors can be achieved in the overall profile of the span.

A tolerance of  $\pm \text{span}/1000$  (on midspan level, relative to the level at the supports, reducing proportionately as the distance to the support reduces) can be achieved; a tolerance of 35 mm can be achieved on spans exceeding 35 m. This is the tolerance given in the MPS, 11.201(ii), but the designer can specify lesser values in situations which require tighter tolerances. Designers should, however, recognise what can be readily achieved by the fabricator/erector and not specify tighter tolerance except where strictly necessary.

In specifying the required tolerance for any particular project, the designer should consider carefully what the effects that deviations up to that tolerance value would have on vertical profile, drainage, self weight, surfacing thickness, etc.

Note, however, that the above discussion about tolerance on level relates to the bridge as a whole, not to each individual girder separately. Where there would be a lack of planarity at top flange level of a composite bridge, the need to maintain a minimum structural thickness of the slab will usually mean that the slab will be cast with its nominal depth over the highest girder, and with a greater depth over the lower girders. In the *Model Project Specification*, clause 11.201 specifies a tolerance of 20 mm on the level of one main girder relative to another, adjacent, main girder; this tolerance is appropriate for a slab of about 250 mm thickness. If any greater tolerance were to be accepted, the design should be checked for the consequent increase in self weight due to the thicker slab.

#### Profile of road surface

The profile of the finished road surface of a highway bridge depends on three elements:

- the profile of the steelwork
- any variation in the thickness (and weight) of the deck slab
- any variation in thickness of the roadway surfacing

There may be some scope for adjustment of steelwork during its construction if it is expected that the deviation from the required geometry will be too great. If the steelwork is not adjusted, the profile can be modified by 'regulation' of the deck slab and/or the surface thicknesses. In these cases the thickness is varied (usually increased at 'low spots') so that a better finished profile is achieved. However, additional thickness means additional self weight and this will increase design moments and forces. Additional thickness and self weight in midspan regions has a much greater influence on moments than does an increase local to the supports. It may therefore be prudent to 'over-camber' the steelwork in some cases to guard against variations (from the intended profile) on the low side. Such addition would be made to the specified 'allowance for permanent deformation' (see GN 4.03). If such a strategy is adopted, it should be made clear to all parties.

In railway bridges, deviations between intended and actual profile of the structure will be accommodated by variations in ballast thickness but, again, the consequences on effects due to self weight and on the level of the track need to be considered.

No special tolerance is given in the MPS.

#### Verticality of girders at supports

There is no tolerance given in EN 1090-2 for the verticality of stiffened webs at supports but verticality must be controlled in order to limit transverse rotation of the bearings and secondary effects.

The verticality of girders at supports is usually set by bracing or cross head systems connected with preloaded bolts. Given a good standard of fabrication there is usually sufficient clearance in the bolt holes to allow

# Guidance Note

## No. 5.03

---

the appropriate degree of adjustment to achieve a tolerance of Depth/300 without resorting to reaming. This is the value given in the MPS, 11.201(iv).

It is emphasised that this check applies to the web itself, and should not be translated to, or derived from, the horizontality or otherwise of the flange plates or bearings.

If this tolerance is not achieved and subsequent adjustment of the bracing system is not readily achievable, a check will be necessary to establish whether the bracing system is capable of sustaining the resulting additional horizontal forces. This situation may well be experienced at the abutments of skewed composite bridges. See comment on girder twist in GN 1.02.

### **Special functional tolerances**

Two classes of functional tolerance are given in EN 1090-2. Class 1, which is the less onerous tolerance, is the default for routine work. Tolerance class 2 will require special and more expensive measures in fabrication and erection. The MPS selects class 1 as the default in 11.301 and provides in 11.302 the opportunity to add other requirements.

### *Attachment of other prefabricated elements*

It is necessary to give consideration to the accuracy of location of fittings required to support or avoid other prefabricated

elements, including non-structural items such as parapets and fascia panels.

The EN 1090-2 class 1 functional tolerance for the location of web stiffeners is  $\pm 5$  mm, which is related to their required location shown as a simple dimension on the design and/or fabrication drawings. Whilst this degree of accuracy is reasonably easy to achieve within a single fabricated element, the consequences of accumulated errors over the joints in a series of consecutive elements should be taken into account in the detailing of the fixings themselves, and these should be provided with some adjustment facility.

If structural stiffeners are intended to serve a dual purpose (i.e. for attachment of fittings as well as for structural purposes), this should be clearly specified, so that any implications on tolerance can be identified.

### **References**

1. EN 1090-2:2008, Execution of steel structures and aluminium structures. Part 1, Technical requirements for steel structures.
2. Steel Bridge Group: Model project specification for the execution of steelwork in bridge structures, (P382), SCI, 2009.
3. EN 1090-1, Execution of steel structures and aluminium structures. Part 1, Requirements for conformity assessment of structural components.

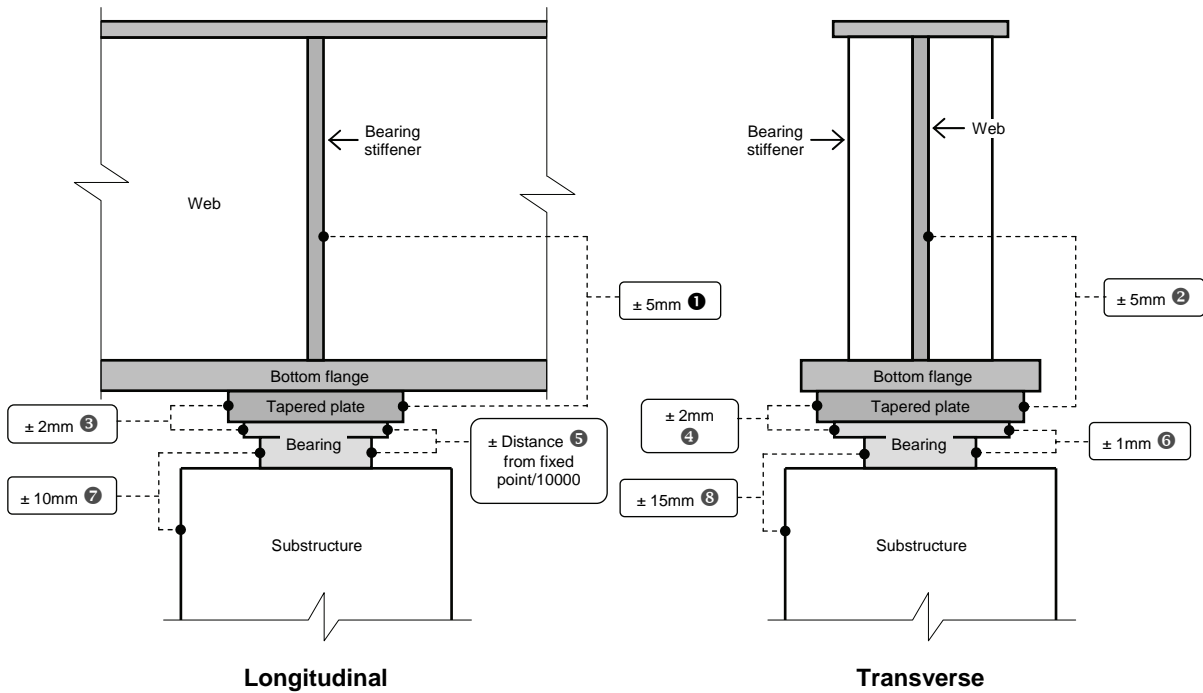

Interface		Commentary
Ref	Deviation	
1	Offset of bearing stiffener relative to tapered plate	Stiffeners and tapered plate are set out by hand, or installed to machine-generated powder-marks on theoretical bearing centreline.
2	Offset of web relative to tapered plate	The web is located manually or by T&I machine, and the centre of the tapered plate is set manually; both are set to the measured centreline of the flange.
3 & 4	Offset of fixing holes in tapered plate and bearing top plate	Both sets of holes are drilled using CNC machines.
5	Overall length, causing offset of top plate of bearing relative to bottom plate	This is caused by cumulative small systematic variations in girder lengths and splice gaps. It should be allowed for in the design translations for the bearings.
6	Slack in bearing	Top and bottom plates are held in position by transit cleats until the steelwork is erected, or by the guides.
7	Position of bearing on substructure	This is accommodated by clearance in the dowel pockets.
8	Position of bearing on substructure	This is due to offset of overall location and variations in width between girders arising from variations in positions of holes in bracing members and stiffeners, widths of stiffeners, gaps in welded joints, clearance in bolt holes, and offsets of webs and tapered plates.

Figure 1 Geometrical deviations



**Scope**

This Guidance Note gives general information on procedures used for cold bending of steel plate produced (to EN 10025) by the reversing or coil plate mill processes. The effect of the procedures on the metallurgical and other material properties of the plate is discussed.

The intention is to clarify the metallurgical effects which can occur, to advise engineers on important product quality considerations and to describe the effect on overall performance.

Stress relieving processes are not covered.

**General**

The bending of plate offers the bridge designer considerable flexibility in forming tailor-made structural shapes including troughs, boxes, girder haunches etc. The degree of bending will vary depending upon the particular geometry required.

Plate may be cold bent for structural applications by a number of fabrication techniques, but the most commonly used methods are the use of a press brake and roll forming.

A press brake is a machine that bends a sheet of metal in a straight line by pressing a knife-edged tool down onto the sheet; the sheet is pressed into a lower tool of appropriate shape. Press brakes are extremely flexible in terms of application and are available in a variety of sizes and capacities. It is unusual, however, to find brake presses which exceed 8 m in width (i.e. along the bend axis); a small number of specialist UK steel bridge fabricators do have much wider machines, but in any case wider plates may be bent incrementally, depending on the skill and experience of the particular fabricator, or by using machines in tandem.

Roll forming is a process in which flat metal plate or strip is fed through a series of rolls and is progressively formed to a given shape. It is a continuous high volume manufacturing process and so is less suitable for conventional bridge steelwork. The roll forming process is usually carried out by building product manufacturers (rather than fabricators) on relatively thin gauge coil, due to limitations on roll capacity, typically less than 6 mm in thickness.

If non-alloy structural steel is to be cold bent during the fabrication process, then consideration should be given to specifying the quality as suitable for cold forming, in accordance with clause 7.4.2.2 of EN 10025-2. That clause requires that the quality be designated by the symbol C at the time of ordering (e.g. grade S355J2C). EN 10025-2 also provides, in Table 12 of the Standard, information on minimum values of inside bend radii for 'cold flanging' of plate, depending upon the grade and thickness. Table 12 refers only to thicknesses less than 30 mm, since it is in this range that the vast majority of applications for cold bent plate lie. It should be noted, however, that the C designation in practice needs only to be specified where very tight centreline bending radii are involved, i.e. close to the limits in Table 12.

EN 10025 is published in several Parts, specifying fine grain steels, steels with improved corrosion resistance and high yield steels in the quenched and tempered condition. Each of the Parts specifies forming limitations and options which can be implemented at order stage to purchase steels with suitable properties for forming.

Previous standard practice permitted cold bending of steel to an internal radius of not less than twice the metal thickness (i.e. a centreline bend radius of  $2.5t$ ). Experience indicates that no problems have been encountered when such a limit is placed on steels for use in bridgeworks.

It is important to note that the criteria relating to cold bending given in the existing product standards relate only to the 'suitability' of the material for this purpose, but give no guidance as to the resulting material properties. This point is often overlooked by design engineers, who invariably assume that the properties remain unaffected and in accordance with those for the original undeformed plate.

Simple bending theory indicates that the bending of plate to a centreline radius of  $2.5t$  induces a surface strain of 20% (close to the ultimate tensile strain) i.e. the material can be bent without tearing. It is important to realise that the cold bending process can alter the *local* material properties, and that the steel



# Guidance Note

## No. 5.04

---

manufacturer should be made aware, at the time of order, if the plate is to be cold bent.

The major effect on material properties of cold bending relates to the Charpy toughness (more specifically the transition temperature), and to the material ductility perpendicular to the axis of bending.

### Toughness

Steel plate which has been cold bent suffers a general reduction in toughness which is evident by an increase in Charpy transition temperature, due primarily to the initial straining and subsequent strain ageing process. Note that it is the *transition* temperature which is affected rather than the upper shelf toughness.

The effect of temperature shift is included in the calculation of maximum permitted thickness values and toughness quality in EN 1993-1-10. For example at a surface strain of 20%, the reference temperature  $T_{Ed}$  is reduced by 60°C (i.e.  $\Delta T_{ecf} = -60^\circ$ )

These shifts in the steel Charpy transition temperature are, however, surface layer effects only and are limited to a very localised area.

### Ductility

Cold bending to tight radii will cause the yield strain to be exceeded in the outer fibres of steel plate. The effect is to locally work harden the steel in these outer layers resulting in an increase in the yield strength (with a consequent reduction in the ultimate to yield strength ratio) and a reduction in elongation at failure. The reduction in material ductility applies mainly to the parallel direction with respect to principal cold straining; reductions in the transverse direction are much less significant.

It should be noted that plate supplied for bridge construction typically has elongation values in excess of the commonly required 22% (for thickness between 3 mm and 40 mm) specified in EN 10025-2.

It is important to remember that the work hardening effect relates only to the surface layers of a very localized area. Indeed, a significant amount of research carried out on the behaviour of cold formed tubes (formed

from coil plate) indicates that performance of the section in bending is at least as good as the hot finished alternative, both in terms of moment of resistance and structural ductility. Similarly, the local reductions in Charpy toughness which occur due to cold bending in the corner areas have little effect on the overall impact performance of the cold formed tube when acting as a structural element.

### Use of bent plate

The principal uses of bent plate in bridgework are:

- in flanges of haunched girders
- as especially large angle sections (as transverse stiffeners in box girders for example)
- as trough sections in orthotropic decks

When used in the above situations, the two considerations are the integrity of the steel after bending and the effect on toughness. Precautions to ensure that cracking is not introduced are discussed below. Considerations about toughness can be related to the use of the bent material.

Any reduction in toughness would be most significant if the material is subject to tensile stresses. This could affect thick tension flanges, but use in those situations will usually involve only relatively large radii (10t or more). It is unlikely that any change of quality grade would be necessary for such use.

Use as stiffeners or troughs may involve tighter radii, but the material is usually thinner and the lower value of limiting thickness given by the reduced reference temperature may be sufficient for such applications.

### Precautions

The notes below give general practical precautions which will be of assistance to the designer who wishes to utilise cold bent steel plate.

- Ensure that the steel is from a supplier who adheres to a rigorous quality scheme with regular inspections.
- **Always ensure** that the cold bent areas of the plate (particularly edges) are **visually inspected** for obvious defects e.g. dents or cracks which may act as initiators for fa-

tigue crack growth or propagation by brittle fracture.

- In the case of cold bending heavy plates or thin plates with tight radii for use in critical locations, MPI may be considered to ensure no cracks are present in the highly strained corner regions.

The designer may wish to check that the fabricator exercises the following precautions:

- Ensure that the steel deforms smoothly within the press brake, and that the plastic strain is adequately distributed by the tool head.
- Exercise care if plate which has been grit (or shot) blasted is to be cold formed, as the hardening effect may lead to loss of ductility in the surface layers and the formation of localised micro cracking on the tension face.
- Exercise care if pickling and hot dip galvanizing cold bent components, because of an increased risk of incipient cracking.
- Avoid cold bending plate with edge defects (e.g. flame cut edges with visible drag lines (see GN 5.06) or notched edges), or with zones that are locally hardened. Grinding of plate edges may be carried out in order to ensure freedom from micro cracks which could propagate during bending.

### Summary

Guidance on the suitability for cold bending relates only to the avoidance of tearing or cracking upon forming; it does not guarantee that the mechanical properties, particularly Charpy transition temperature and material ductility, will remain the same as for the as-received plate.

The designer should appreciate that cold bending to tight radii can, in the absence of stress relieving, modify the resulting material properties, but only in the surface layers at localised areas.

No problems should be experienced in ordinary bridgework as a result of cold bending, so long as the steel plate is supplied by a quality producer and advice is sought at the time of

ordering about the recommended minimum bend radii for the grade of steel.

### References

1. EN 10025: Hot rolled products of structural steels.  
Part 1: 2004, General technical delivery conditions.  
Part 2: 2004, Technical delivery conditions for non-alloy structural steels.  
Part 3: 2004, Technical delivery conditions for normalized/normalized rolled weldable fine grain structural steels.  
Part 4: 2004, Technical delivery conditions for thermomechanical rolled weldable fine grain structural steels.  
Part 5: 2004, Technical delivery conditions for structural steels with improved atmospheric corrosion resistance.  
Part 6: 2004, Technical delivery conditions for flat products of high yield strength structural steels in the quenched and tempered condition.
2. EN 1993-1-10:2005, Eurocode 3: Design of steel structures. Material toughness and through-thickness properties



**Scope**

This Guidance Note explains the need for marking and describes the types of marking commonly used in bridge steelwork. Practice at the steel mill and in the fabrication shop is covered. Recommendations of best practice in the fabrication shop are given.

**The need for marking**

Steel from the mills needs to be marked to ensure identification and traceability of the material. This is important for both the steel-maker and the fabricator.

During erection, a clear and simple marking system for the fabricated components is vital to ensure that all components are correctly located and orientated within the structure.

Over the last 20 years, bridge construction sites have become progressively more constrained by the existence and alignment of other infrastructures. The incidence of varying degrees and combinations of skew, vertical curvature and plan curvature has led to a much greater likelihood that there are components that are apparently identical, but which have small dimensional differences; if wrongly placed, there can be significant effects on structure geometry and possibly on structural adequacy.

Identification marks on components should be capable of being easily found and read, after possibly several weeks of storage on site. Because identification may have to be made in less than ideal conditions of weather and light, the marks must be clear and easily and safely accessible, whether the components are on transport or stored at ground level.

**Methods of marking - steel products**

The following are examples of marking procedures followed by Corus:

*Plate*

A dot-matrix stamp mark gives information on mill, cast number, steel grade and plate number that will relate to the test certificate. Additional paint marking gives information on plate dimensions, weight, order number and fabricator requirements.

*Sections*

Stick-on labels. Each label has a bar code and includes information on section dimensions and length, steel grade and piece weight, plus Corus and customer references.

*Strip (coil)*

Label tied to the steel binding. Each label gives information on steel grade and coil weight, together with references.

*Tubes & pipes*

Stencil marks on tubes supplied as individual lengths (RHS over 160 x 160 mm, CHS over 219 mm); labels on each bundle for smaller sizes. The marking includes section size and thickness, steel grade and standard, and cast number.

Where the steel is supplied to a stockholder, the above traceability should be maintained.

**Methods of marking - in the fabrication shop**

Within the fabrication shop, components are usually identified with white paint or indelible marker pen. Sub-assemblies are then usually identified in the same way.

While perfectly adequate in the confines of the fabrication shop, such marks deteriorate quite quickly outside and can only be regarded as temporary.

In order to add certainty in terms of subsequent material traceability, a permanent mark should be made to each welded assembly or separate component before it leaves the fabrication shop.

Within a shop welded assembly there is seldom a need to add a permanent mark to each component, as the origin of the components forming that item can usually be reconciled via cutting sheets and material inventories.

The normal method of marking by fabricators in bridge construction, and the method that has been used for many years, is hard stamping in appropriate locations.

**Types of marking**

A hard stamp is a form of punch which, when struck with a hammer, produces an indentation on the surface of the steel in the form of a letter of the alphabet or a number.

# Guidance Note

## No. 5.05

---

Hard stamp sets can be obtained comprising 26 letters and 10 numbers (0 to 9) and are available in various sizes. In bridge construction, 12 mm character height is usually used. Some saw-drill and plate cutting machines incorporate hard stamping devices where the imprint is obtained via hydraulic pressure rather than percussion. This type of equipment is used to mark rolled sections and girder parts, and is gradually replacing manual hard stamping.

Three types of hard stamp are available:

- 1) The “standard stamp” where the leading edge of the character is sharp and angular.
- 2) The “low stress stamp” where the leading edge of the character is radiused.
- 3) The “dot matrix stamps” where the character is formed by a number of pointed tips.

The “low stress stamp” and the “dot matrix” stamp were developed for the aircraft industry who deemed the sharp imprint of the “standard hard stamp” to be a potential source of stress concentration and therefore undesirable in fatigue sensitive areas. The “low stress stamp” with its rounded indentation gave rise to lower stress concentration. The “dot matrix stamp” was considered better again.

The “low stress stamp” has been widely adopted by the offshore industry, and is widely used by steel suppliers and bridge fabricators when stamping by hand.

The “dot matrix stamp” is used by some steel plate suppliers who have CNC (computer numeric controlled) stamps to identify cast numbers and material grades. It is also commonly used in automatic stamping equipment on saw-drill and plate-cutting machines

While the shape of the root of the indentation is important with respect to stress concentration, the location of any such mark is probably more significant.

“Weld writing” can be used to mark girders but it should only be done by robotic welding. Manual “weld writing”, although robust and often used in building work, is totally unsuitable for any primary or secondary components in a bridge. The process is substantially un-

controlled in terms of heat input and there is a high risk of introducing serious surface defects.

### Location of permanent marks

Few components within a bridge have constant stress distribution throughout their length and, in most cases, it should be possible to find a location of low static and cycling stress where the benefits of hard stamping can be obtained and the risks of impairment of fatigue capability are minimised.

Figure 1 indicates acceptable hard stamp locations for typical bolted construction where the above objectives may be achieved.

### Covering of marks by protective coatings

As most components and sub-assemblies in steel bridges receive protective treatment, and as the various coatings tend to fill hard stamp indentations, the depth of the indentation can be important in terms of the clarity of the mark on site. This is more of a problem with the modern thicker epoxy coating than it was with the previously used high solvent coatings which have been abandoned under the Environmental Protection Act.

For equal effort and size of character, the most distinct indentation is that made by the “standard hard stamp”, followed by that of the “low stress stamp” and then by the “dot matrix stamp”.

The typical indentation for the “standard stamp” applied manually is between 300 and 500 microns. Typically, the combined specified minimum thickness of shop applied protective treatment is in the order of 300 microns. However, it should be remembered that in order to achieve reasonable certainty of a specified minimum thickness, the applicator has to deposit a greater average thickness. Generally, it is held that the necessary average is in the order of 33% higher than the specified minimum.

It is clear, therefore, that for any manually applied hard stamp, *modern* shop coatings as specified for bridge steelwork are likely to substantially obscure the hard stamp. In the case of automated markings, this is less likely because such markings tend to be at least 50% deeper.

The effective way around this potential problem is to mask the hard stamp area after priming or metal spray and sealer. In the majority of cases, the extra paint work on site to reinstate these areas after erection would be insignificant.

### Marking weather resistant steel

For weather resistant steel, hard stamping is again the best method of permanent identification. However, for temporary marking in the fabrication shop, care should be taken to avoid the use of wax or oil based markers, because even after blast cleaning some residue remains and such marks locally effect the weathering characteristics; they can be apparent for many years afterwards.

### The Risks

The members of the Steel Bridge Group know of no case where hard stamping, either standard or low stress, has been the cause of failure of any part of a bridge structure.

Theoretically, a severe stamp mark that ends up in a particularly fatigue-prone location could lead to problems, but to prohibit hard stamping altogether is not the answer as it remains the most reliable form of long term identification.

Network Rail documents define a 'hard die stamp' as a sharp nosed stamp (i.e. the 'standard stamp' described above) and they prohibit its use by either steel supplier or fabricator. They do, however, accept the use of 'low stress' or 'dot matrix' stamping by both supplier and fabricator.

At present, all methods of identification other than hard stamping are insufficiently robust for typical bridge components and are too reliant on individuals to record and transfer markings,

particularly during protective treatment. The problem is not so much with large items such as main girders, but with the numerous and smaller bracings and splice plates, which are equally important in terms of correct positioning and orientation in the structure.

### Recommendations

- 1) Use "low stress hard stamps" for the identification of sub-assemblies and components to be sent to site.
- 2) Identification hard stamp markings should be located in the area of lowest cyclic stress within each component or sub-assembly.
- 3) Hard stamp marks should be visible after assembly in case there is a need for checking.
- 4) The contractor/fabricator should provide a written statement of his marking method with locations given for marks on each component or sub-assembly. Consideration must be given within this statement to orientation of component where it is important (i.e. north end, west end, etc.)
- 5) Identification markings should be kept as brief as possible, although it should be recognized that multi structure projects will inevitably require more characters.
- 6) Standardize the approach to identifying girders within the bridge. Use a simple matrix, use letters to identify girder lines transversely and numbers to identify girder positions within each line.
- 7) If there is a risk that the hard stamp indentation may be filled with paint, mask locally during application of the undercoats (marks should in any case not be located in a corrosion-vulnerable area).

# Guidance Note

## No. 5.05

---

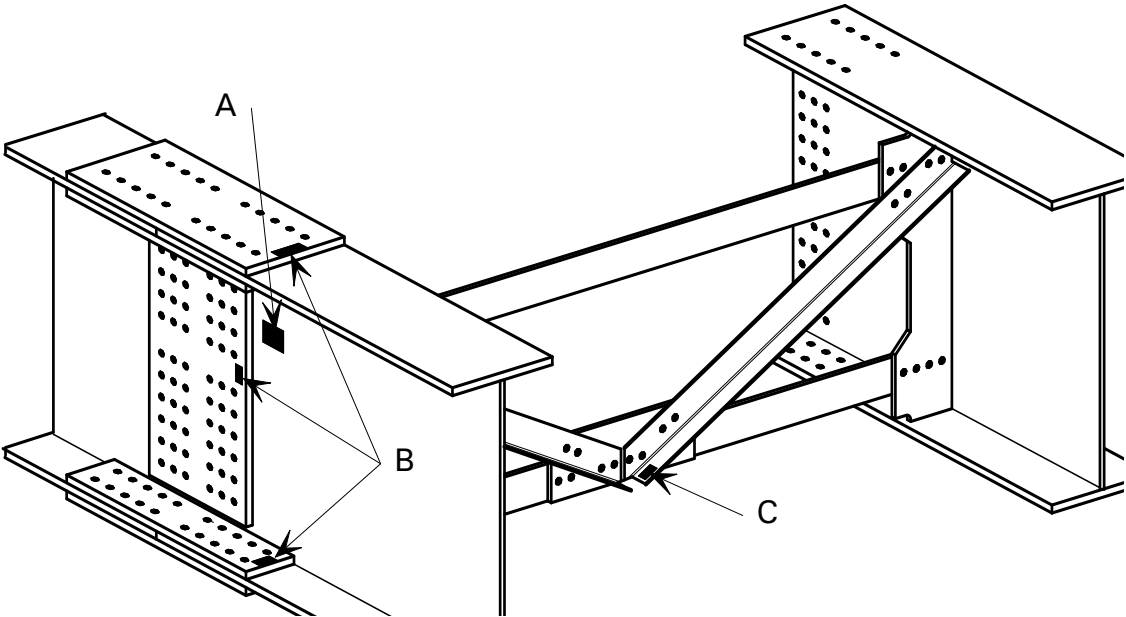

**Figure 1** Locations for hard stamp marks

- Notes:
- (A) Web plate marked close to neutral axis
  - (B) Cover plates marked close to unstressed edges
  - (C) Bracing members marked in lightly stressed region of outstands

**Scope**

This guidance note relates to the thermal cutting of structural steels in the fabrication of bridge steelwork and covers the flame and plasma processes. Laser cutting has gained some popularity in ship building for cutting relatively thin material, but there are considerable health and safety problems in controlling and containing the cutting beams. It is seldom used in bridge construction at present.

**The flame cutting process**

The process functions on the principle that a jet of pure oxygen is directed at a surface that has been preheated to its ignition temperature. The material in the path of the jet is oxidised and ejected, resulting in a cut. Figure 1 shows a diagrammatic view of this process.

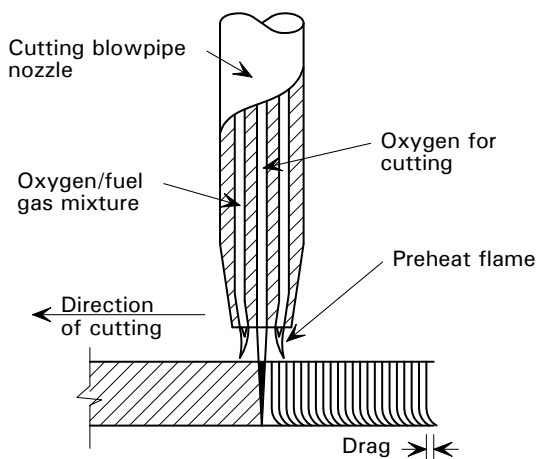

**Figure 1** Flame cutting of metal

The process does not function on all metals; the following conditions must be satisfied:

- The ignition temperature of the metal must be lower than its melting point. (The ignition temperature is the point at which the metal will ignite in pure oxygen.)
- The melting point of the oxide must be lower than the ignition temperature of the metal so that the oxide can be ejected from the cut by the force of the oxygen jet.
- The heat generated by the oxidation reaction must be high to perpetuate the cut, while the thermal conductivity of the metal must be low in order to contain that heat.

These conditions are satisfied by structural steels.

**The plasma cutting process**

In plasma cutting, gas is transformed into plasma when it is heated, which results in extremely high temperatures of up to 27,000°C being generated. Figure 2 shows a diagrammatic view of this process.

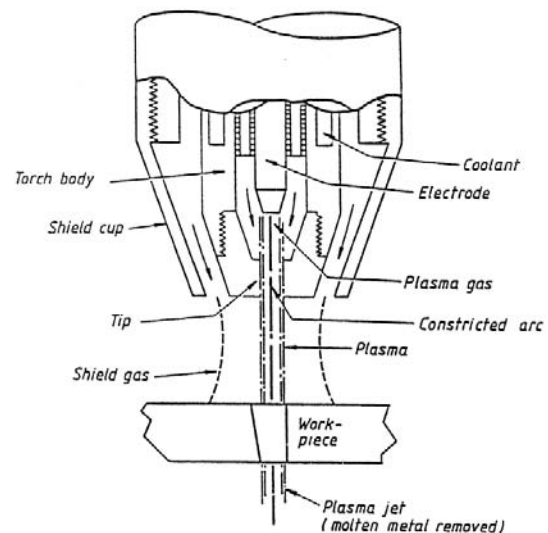

**Figure 2** Plasma cutting of metal

The plasma arc cutting process severs metal by means of this highly constricted arc jet, which has sufficient energy and force not only to melt the metal but also to eject the molten material. Because melting rather than oxidation produces the cut, plasma cutting can be used to cut any metallic material. It requires no preheat and produces minimal distortion in the material being cut.

Plasma cutting has been in use for bridge construction for a number of years. Cutting speeds are relatively high, and the cut surface tends to be harder than the equivalent flame cut surface. Cutting is normally carried out under water, to limit the production of ozone and oxides of nitrogen. It also reduces the noise and light emissions.

**Quality of cut surface**

In order to achieve a good quality cut the following parameters require control:

- The cutting speed;
- The distance from the cutting nozzle to the work piece;
- The cutting nozzle size and condition;



# Guidance Note

## No. 5.06

---

- The pressures of the heating fuel gas and oxygen (flame cutting);
- The pressure of the cutting oxygen (flame cutting);
- The power setting (plasma cutting).

The overall degree of control of the movement of the cutting head is also very important. This is a matter that has improved greatly with modern CNC (computer numeric controlled) equipment, leading generally to a much squarer and more uniform cut than could previously be consistently achieved.

EN 1090-2 (Ref 1) specifies standards of cut surface quality in terms of squareness (perpendicularity/angularity) and depth of drag line (mean height of profile). However, these parameters are only appropriate to laboratory conditions, so the assessment of flame cut surfaces on the shop floor is best achieved by having available samples which have been calibrated to the particular quality requirement, so that they can be used as comparators.

Figure 3 shows three flame cut surfaces. The right hand side shows surfaces slightly weathered and the left hand side shows the effect of blasting with chilled iron grit. All three samples were assessed on their as-cut surfaces in accordance with the provisions of EN ISO 9013 (Ref 2) for depth of drag line. In the upper sample the depth is well within Range 3 and the middle sample is slightly over the limit for Range 3. The lower sample is well above Range 3, but within Range 4.

The Range 4 standard required for EXC3 can be achieved with as-cut surfaces with both processes, but a plasma cut surface is unlikely to comply with the Range 3 squareness standard for EXC4. This would not normally matter except where the surface was required to be fitted to another component.

Individual / isolated defects in the cut surface, such as gouges (see Figure 4) can occur from time to time. These are unacceptable in bridge work and should be dressed out by grinding to a smooth profile. Weld repair of such defects should only be considered as a last resort for deep gouges, and such repairs should always be subjected to surface crack detection after welding.

### Drag Lines

Despite controls exercised on the matters listed above, the thermal cutting process tends to lead to the formation of drag lines on the surfaces of the cut. A 'drag line' is defined in BS 499 (Ref 3) as "Serration left on the face of a cut made by thermal cutting", and the standard goes on to define 'drag' as "The projected distance between the two ends of a drag line" (i.e. measure relative to a line square to the material surface - see Figure 1).

When equipment settings are perfectly adjusted, it is possible to produce a cut with an extremely smooth and flat surface, where drag lines are not readily apparent (i.e. the serrations are very shallow, or the 'depth of drag line' is small). However, maintaining all the variables within the bounds that produce this standard, on components of the scale encountered in bridge work, is very difficult, and drag lines are usually evident to some extent.

In Table 8.1 of EN 1993-1-9 (Ref 4) there are fatigue categories for plain members with and without drag lines. Detail 4, category 140, requires that all visible discontinuities are removed while Detail 5, category 125, allows "shallow and regular drag lines". Both of these categories will only govern fatigue life of the member where there are no transverse butt welds, no fillet weld attachments and no drilled holes (all of which are lower categories), and as such the requirement for ground edge surfaces for fatigue reasons is unusual in bridge construction. Note also that the UK NA to EN 1993-1-10 requires special testing and inspection for category 140.

If Detail 4, category 140 is needed in exceptional cases, grinding should only be specified at those locations.

In the past, regrettably, it has often been the case that grinding all cut edges has been specified, with a disregard for the costs that are being added for no benefit in performance. Such a requirement is not included in EN 1090-2 or the MPS (Ref 5) and hopefully that general requirement will not be made in future.

**Hardness of the cut surface**

The main purpose of controlling the hardness of a cut surface is to avoid degrading the properties which control the susceptibility to fatigue and brittle fracture.

Optional limits on the hardness of thermally cut free edge surfaces are given in clause 6.4.4 of EN 1090-2 but they are not a result of direct research into thermal cutting; they have been imported from welding research. The limit for S355 steel to EN 10025 is given as 380 HV10 but there is no mention of the fact that it is not possible to achieve that level of hardness when cutting with plasma.

When flame-cutting, slower cutting speeds help to reduce surface hardness and most fabricators use cutting speeds below those recommended by equipment manufacturers for this reason. Excessively slow cutting speeds result in a rough and irregular cut surface as the preheating temperature gets too close to the melting point of the material.

Plasma cutting has a narrower "window" of settings that will produce straight clean dross-free cuts so there is little that can be done to adjust the process to reduce the hardness of the cut surface. Bridge parts such as webs, flanges, stiffeners and cover plates up to 30 mm thick are routinely cut using plasma, and hardness values for S355 steels cut by this process typically lie between 400 and 600 HV10.

Research carried out in the US and by Corus in the UK has shown that this increased hardness has no effect on fatigue resistance. There are indications however from a small number of impact tests carried out by Corus on small un-notched specimens at -100°C that it slightly reduces the resistance to brittle fracture. There are practical difficulties however with obtaining impact results from un-notched specimens, so the amount of data available is not sufficient for a proper quantitative comparison to be made. This reduced resistance is also confirmed by the fact that untreated plasma-cut surfaces tend to crack when cold-formed.

It is therefore concluded that reduced fracture resistance in a cut surface is not detrimental to

the performance of bridge steelwork unless the surface:

- a) is subject to local shock loading such as vehicle impact, or
- b) is subsequently cold-formed, or
- c) has a geometrical discontinuity on the surface.

Thus it is advisable to apply the 380 HV10 limit only to free edge surfaces where one or more of the above apply, and this is reflected in the advice given in clause 6.401 of the MPS (Ref 5).

**Suitable surface for sprayed metal**

A note at the end of clause 10.2 of EN 1090-2 warns that thermally cut surfaces are sometimes too hard for blast cleaning to achieve the specified surface roughness and might therefore have to be ground. Grinding will ensure that a suitable blast profile can be achieved to enable sprayed metal coatings to adhere. There are, however, two other and equally valid methods of achieving adhesion; they are:

- 1) After general blast cleaning with chilled iron grit, thermally cut faces are blasted with alumina grit. This provides a sharp profile on harder surfaces, suitable for the application of flame sprayed aluminium or zinc.
- 2) Use of the electric arc method of spray application. This achieves adhesion values in the order of four times that of the more common flame spray process in the case of sprayed aluminium; it can therefore tolerate a lesser blast profile to achieve the required adhesion. If an applicator or fabricator proposes to use this technique it is advised that he should be asked to demonstrate the resulting adhesion levels by test. In the case of sprayed zinc, however, the process offers no increase in adhesion.

**Adhesion testing of sprayed metal**

The SHW 1900 series (Ref 6) calls for adhesion trials in the form of pull off tests on sample plates of the same grade as the parent plate being coated. A successful procedure trial on this basis gives little indication of the adhesion performance on thermally cut surfaces. If there is an adhesion problem the probabilities are that it will be on a thermally cut surface.

# Guidance Note

## No. 5.06

---

Specifiers would be well advised to supplement the provisions of SHW clauses 1910 and 1915 by requesting a method statement for the application of sprayed metal to the flame cut surface of the thickest material anticipated in the particular project, and a procedure trial in the form of a pull-off test on such a cut surface.

Production tests for adhesion on thermally cut surfaces are best carried out by grid test, as defined in BS EN ISO 2063 (Ref 7).

### References

1. EN 1090-2:2008, Execution of Steel Structures and Aluminum Structures, Part 2: Technical Requirements for the Execution of Steel Structures.
2. EN ISO 9013:2002, Thermal cutting - Classification of thermal cuts - Geometrical product specification and quality tolerances
3. BS 499: Part 1:2009, Welding terms and symbols - Glossary for welding brazing and thermal cutting
4. EN 1993-1-9:2005, Eurocode 3: Design of Steel Structures, Part 1.9: Fatigue
5. SCI Publication P382, Model Project Specification for the Execution of Steelwork in Bridge Structures;
6. Specification for Highway Works, Series 1900, Protection of steelwork against corrosion, 2005.
7. EN ISO 2063:2005, Thermal spraying. Metallic and other inorganic coatings. Zinc, aluminium and their alloys.

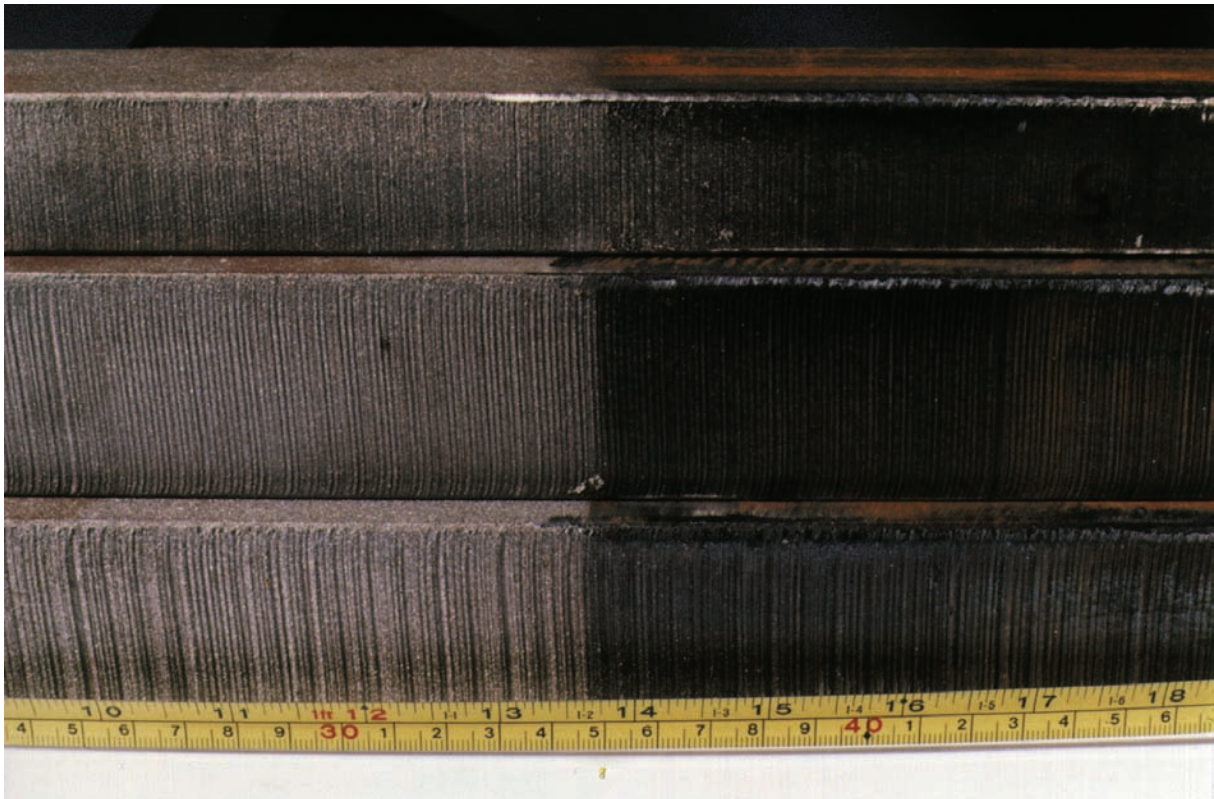

**Figure 3** *Drag lines produced by flame cutting*

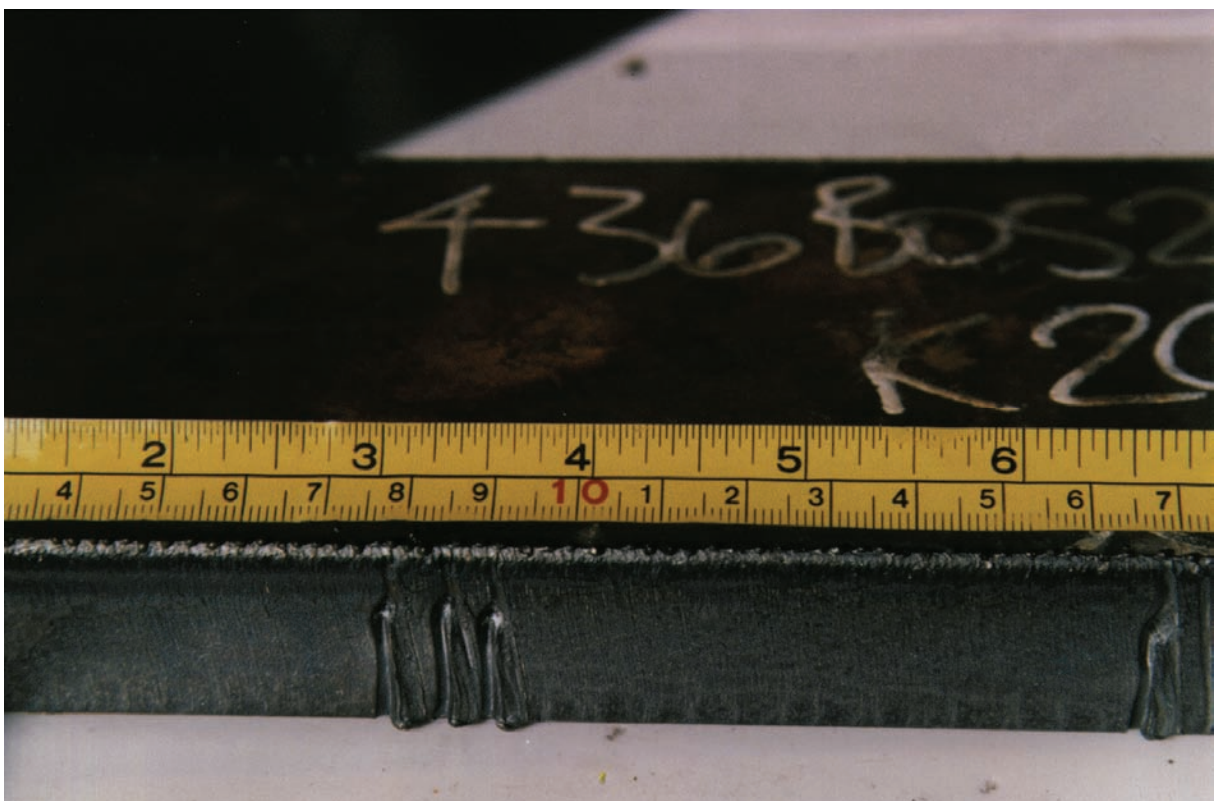

**Figure 4** *Unacceptable isolated defects in flame cut surface*



### Scope

This Guidance Note gives advice on the practices and problems that can arise in straightening or flattening the kind of steel used in bridgework. It covers both the preparation stages, when making components which are then assembled into structural elements, and attempting to rectify distortions in the finished elements arising from welding or damage due to careless handling.

In some designs, steel is cold-formed to produce a desired shape without the use of welding. This process is covered by GN 5.04.

### Hammering

*Hammering is not permitted.* This bald statement is included because experience has shown that the end result is almost invariably unacceptable visually: edges are damaged and made irregular and the hammer impact marks are highly visible and very hard to disguise.

There is a possible mechanical effect as well, caused by the very local surface distortions at the impact locations which leads to some surface hardening. This effect is very difficult to detect and quantify, but it is never beneficial in the case of bridgework and can be positively detrimental in fatigue-prone areas.

### Flame straightening

This is a commonly used way of preventing or rectifying the unavoidable distortions that occur throughout the fabrication processes. Used in a controlled way it is very effective. See Figures 1 to 3 for typical applications.

The use of additional, controlled heating during the production of fabricated steelwork is part of the specialist expertise of the fabricator. Some quite useful and practical papers have been written from time to time on the subject, but most of the authors recognize that they are at best a guide to some basic physical effects, and that there is usually a need for some trial-and-error before the optimum result can be achieved. Some references are included at the end of the note which may help understanding of the mechanisms involved. As far as the designer is concerned, the advice is to leave it to the fabricator to develop his own procedures and not be too concerned about the exact details, provided the requirements of clause 6.5.3 of EN 1090-2 are observed.

It is therefore necessary to exercise control of the nature of the heating process, level of temperature and time of heating up, time at high temperature and rate of cooling.

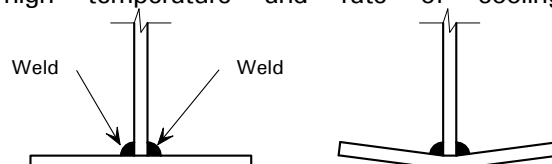

**Figure 1** Flange peaking due to welding

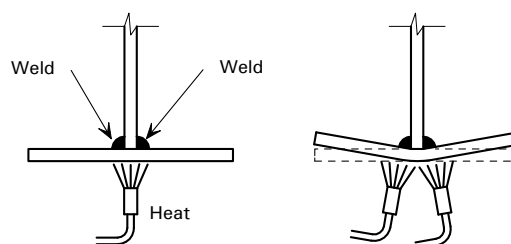

**Figure 2** Heating to avoid or remove peaking

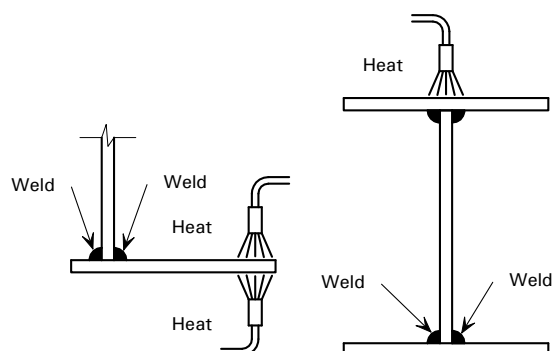

**Figure 3** Compensation heating to avoid residual curvature

### Heating processes

Unless there is some particular reason for doing otherwise, the heating should be carried out by an oxygen/propane blowtorch fitted with the appropriate nozzle for the application. Nozzles are available in a range of sizes, for use on material from thin sheet steel to thicknesses of 100 mm and more.

Burning torches, which use an acetylene fuel, burn at a temperature which can cut steel and hence will damage the surface of the element. They should not be used for this work, even if they have a 'preheating mode', because there is the risk of opening the wrong valve and causing serious damage. Other means of heating, such as radiant or contact ceramic electrical heaters are not usually used because of the expense in setting up the equipment, the

# Guidance Note

## No. 5.07

running costs and the relatively slow heating up rate.

### *Heating temperature*

This is one of the most critical items to be controlled. Before the introduction of EN 1090-2 the usual method simply limited the temperature to 650°C and prohibited accelerated cooling, but EN 1090-2 requires that a procedure is developed with evidence of mechanical tests and more control over the process.

With the wide range of structural steels now available, many for special applications which are themselves manufactured by strictly controlled regimes of thermal and mechanical rolling, it is not possible to give simple rules of what is and what is not acceptable. What matters is the whole life heat history of the material. Even the 650°C limit will have an effect if it is sustained for many hours: this is the basis of stress-relieving. Conversely, going quickly to some temperature between 650°C and 850°C and then letting it cool in still air will be unlikely to affect the properties of most commonly used bridge steels. Holding at these higher temperatures for extended periods (half an hour or more) will begin to affect the strength and/or toughness of most steels, and going over 900-950°C is likely to affect most steels in some way. Those steels which are produced by the thermomechanical routes are more likely to be affected and the advice of the manufacturer should always be sought if in doubt.

It is surprisingly difficult to control the temperature accurately. If over-heating is suspected, it is desirable to be able to check it! Most of the temperature measuring devices in fabrication shops are for measuring pre-heating temperatures, i.e. up to a maximum of 200°C. Digital surface temperature measuring instruments are available which cover a range up to 750°C and others can be obtained which read over 1000°C. The other practical way of controlling the temperature is by colour, or, to be more precise, by the lack of colour! It so happens that steel begins to glow as the temperature rises but unfortunately the first perceptible indication is at about the normal maximum (i.e. 650°C). Hence, if there is a visible reddening, the temperature is almost certainly at or over 650°C. The problem is compounded out of doors when the perception

is somewhat masked by the incident light. If a temperature-colour chart is used for reference, it must be used within the stipulated constraint of *very subdued light*.

Water and air jets are commonly used in shipyards to assist rapid cooling, but they can have a highly detrimental effect on the material properties, particularly on the surface. Any accelerated cooling must be verified by a procedure trial before being used on bridge steelwork.

### **Mechanical forming and restraint**

The other way of straightening or rectifying unwanted twists, bows or other distortions, is by the application of sufficient external force to restrain the element or to distort it permanently to the desired shape.

### *Restraint*

The best way of avoiding the problem of distortions is to carry out the assembly and welding of elements in jigs or fitments which are themselves sufficiently stiff and rigid to restrain the fabrication throughout the whole process and to hold it in shape until it has cooled to ambient temperature. However this is neither practical in all circumstances nor entirely effective for all the parts of a complex element. In addition the resulting fabrication will still contain locked-in (*residual*) stresses which, if it is subject to further heating or even shaking (*for example, while being transported significant distances*) can result in some change of shape. The fabricator cannot avoid this; he can do something about it, but he will not achieve perfection.

### *Mechanical straightening*

Straightening can be carried out locally with relatively small hydraulic jacks, or in large presses, bending machines or rollers for whole sections or large elements.

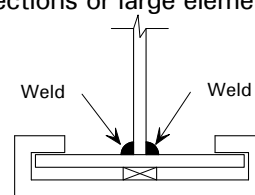

Stronbacks at close centres

**Figure 4 1** *Mechanical restraint*

As with heat straightening, there are no absolute rules about what is permitted or not

permitted and this is another part of the fabricator's expertise. Indeed, it is quite common to use a combination of heating and external force, both controlled, to achieve the required result.

This acceptable use of mechanical straightening or forming applies to situations where there are relatively small strains involved which have little or no effect on the mechanical properties of the material itself

For advice where the material is subject to significant strain, such as when forming a flange on a bent-plate stiffener, reference should be made to GN 5.04. As a guide to what is significant and what is not, reference can also be made to the literature of those firms who provide a service of rolling sections to curved shapes. It will be seen that the sort of mechanical straightening envisaged by this clause is most unlikely to have an effect on the material properties.

What is more important is to be aware of the potential for damage to or even fracture of weldments in the straightening process. This is most likely when outstands, flanges and stiffeners, are forced back into shape; indeed the welded attachment is more likely to break than the stiffener to bend. For this reason the last stage of any straightening procedure must be a complete visual re-check of *all* the local and adjacent welds. Where the distortions had been severe, (say two to three times the allowable tolerance or more) it would be prudent to require NDT for surface-breaking defects on *all* adjacent welds and sub-surface checks, if possible, in the region of greatest strain.

Where the correction required is significant, the work can also affect the adjacent platework, causing bows in stiffeners and buckles in webs. Hence these dimensional checks must be repeated after all straightening is complete.

#### *Presetting*

In some applications the element, or part of it, is pre-set by mechanical forming so that the subsequent application of heat from the welding process, working in the opposite sense on cooling, produces the desired shape without any further work. A common use of such is the pre-setting of flanges of plated girders (see

Figure 5). However most fabricators do not have equipment suitable for doing this over long flange lengths and it is impractical to do this on curved pieces.

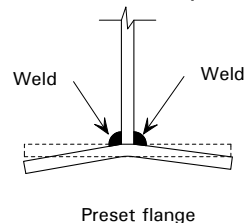

**Figure 5** *Mechanical presetting*

#### **References and further reading**

1. EN 1090-2 Execution of steel structures and aluminium structures. Part 2, Technical requirements for steel structures.

A number of published papers and specific chapters of books deal with the problem of distortions arising from welding. The following is a selection:

2. Practical design against weld distortion in fabricated beams, Irwin & May, Proceedings Instn Civ Engrs, Part 2, 1989, Vol 87, Sep, 317-341.
3. Basic Welding Data, No. 17: Welding Problems. Welding and Metal Fabrication, Aug/Sep 1990.
4. Heat treatment of Welded Steel Structures, Croft DN, Abington Publ, 1996, Chapter 1.





**Scope**

This Guidance Note gives advice on design code requirements for the sizes and positions of holes for preloaded bolts used in bridge steelwork. Advice is also given on current practice in fabrication and erection. Holes for bolts other than preloaded bolts are not covered by this Note.

**General requirements**

The design resistances for preloaded bolts given by EN 1993-1-8 apply where the execution of holes is in accordance with EN 1090-2.

**Diameter**

The hole diameters for normal round holes, oversized holes and slotted holes, are defined in EN 1090-2 (Ref 1), Clause 6.6.1. For holes other than normal round holes, EN 1993-1-8 Table 3.6 (Ref 2), gives reduction factors for the slip resistance.

**Elongation**

Drifts (close-fitting tapered pins of hardened steel) are necessary to bring holes in the various plies into alignment, so that bolts may be freely inserted. GN 7.05 comments that on a large bolt group, the plates forming the joint may need various relative movements to work the bolts into the holes. This is normally done with drifts. Limits on elongation produced by drifting are given in EN 1090-2, clause 6.9.

**Back marks**

Minimum edge and end distances for bolt holes (back marks from the edge of the element) are given in EN1993-1-8 but Clause 3.5 (2) indicates that for structures subjected to fatigue the larger values in EN1993-1-9 (Ref 3) should be used. The symbol  $d$  used in Table 8.1 in EN 1993-1-9 in the formulae for edge and end distance and spacing is not defined. It should be taken as the hole diameter for edge and end distance, and as the bolt diameter for bolt spacing, in line with existing UK practice.

**Tolerances**

Functional manufacturing tolerances for the position, spacing, twist and shape of fastener holes are shown in EN 1090-2, Table D.2.8. The tolerance on hole diameter for

preloaded bolts is given in EN 1090-2, clause 6.6.2.

Designers should remember that all dimensions can only be achieved within practical tolerances. It is good practice to dimension the hole positions at least 5 mm further from an edge than the minimum value but generally the bearing resistance of the fastener may be determined on the basis of the chosen nominal dimension, with no reduction for tolerance. It may be noted that EN 1090-2 specifies a zero negative tolerance on hole position from the end of a member but no tolerance is specified on distance to the side of a member.

**Methods of marking and drilling hole groups**

Many techniques are used by fabricators to achieve alignment of holes, some of those most commonly used are described below:

**Individual manual marking and drilling of holes.**

Errors are probable within each hole group and between groups. Satisfactory for small isolated hole groups only.

**Match marking**

Achieved by pre-drilling approximately half the holes in the components, then assembling the components in their calculated relative geometry and marking the holes through. The components are then dismantled and drilled. The system is especially effective for complex geometry, but requires accurate drilling to the marks on dismantling. The location and orientation of components so drilled should be recorded as parts nominally identical may not be subsequently interchangeable.

**Bush templates**

Used to set out large hole groups, typically web and flange connections, on fully assembled and welded girders or panels. Drilling is carried out through the template, typically using a radial arm drill. Hardened bushes are inserted in the holes of the template to avoid wear from the drill bit. The accuracy of holes within a group is good. Inter-group dimensions are subject to general setting out tolerances.

# Guidance Note

## No. 5.08

---

### *CNC plate drills*

Computer Numeric Controlled (CNC) drilling beds that can provide any pattern of holes on plates prior to assembly. The relationship between holes in a group is good. The initial inter-group dimensions are good, but these are subsequently modified by the difference between the anticipated and actual weld shrinkage, as components so drilled are joined into fabrications. It should be appreciated that methods for calculating weld shrinkage provide only broad approximations.

### *CNC girder drills*

Fully computer controlled machines that can provide accurate hole groupings in fully assembled and welded plate girders or panels, either at the ends of components or at intermediate positions. Such machines remove the uncertainty of allowances for weld shrinkage and give good relationships between holes in a group and good relationships between groups of holes measured along the member. However the machines' datum devices rely on uniform girder cross sections. Assembly tolerances can therefore produce small lateral shifts of hole groups.

### *CNC saw drill lines*

These can provide accurate hole patterns and inter group dimensions on rolled sections or narrow plates.

Each fabricator will have his preference which will be governed by his capital plant, the space available and his view on the risk of misfit for the particular joint.

Holes for bridges may be formed by drilling, laser, plasma or other thermal cutting with the proviso in EN 1090-2, Clause 6.6.3 that the finished hole complies with the local hardness and surface quality requirements in Clause 6.4. In practice however it is difficult to satisfactorily form a round hole or the curved sections of a slotted hole by thermal cutting.

### **Rectification of misaligned holes**

On final assembly or trial erection there is a probability that some holes may be found to misalign by an amount that cannot be accommodated by normal drifting operations (i.e. the

degree of misalignment is such that the forces in drifting distort the metal around the holes, or there is misalignment to the extent that drifts cannot be entered).

If the amount of misalignment is significant then a modified splice plate or bracing may have to be produced. Alternatively a hole can be plug welded and re drilled but this approach should only be adopted with the full knowledge and agreement of the designer.

It is more likely, however, that the amount of misalignment is relatively small and in this situation the solution for many years been was to ream out that hole by the minimum amount to get the bolt into the modified hole without force.

Reaming is an effective and economic solution to remedy localized and minor misalignments. As long as the reamer diameter is equal to or less than the original hole size, it creates a degree of slotting in each hole in each ply forming the joint. The amount of metal removed from each ply may not be equal, as the tool tends to create greater elongation in the thinner plies than in the thicker plies, should they be misaligned.

Tests have shown that over-sizing and slotting of holes can significantly influence the level of bolt preload when bolts are tightened by the strain control method, i.e. the part turn method. Because the head of the bolt is seated on a reduced area, due to the enlargement of the hole, there tends to be localised yielding and distortion which causes a partial relaxation of the preload in the bolt.

It has also been shown by test that the bolt clamping forces are reacted within the plies of the joint over relatively small areas local to each bolt. Removal of metal by hole enlargement causes the inter-ply load to be reacted over a smaller area, and therefore increases the inter-ply pressure. Excessive inter-ply contact pressure can cause local flattening of surface irregularities and thereby a reduction in slip resistance of the joint

Slip resistance normally governs the joint design, at either SLS or ULS depending on the design category, so both of the above issues

are important if holes are enlarged beyond the normal specified clearances. The shear and bearing resistances can also be affected.

#### *Slip resistance*

Research has shown that the potential for preload relaxation can be overcome quite easily by the addition of an additional hard round washer under the bolt head. For M24 bolts this approach is satisfactory in bolt holes enlarged to bolt diameter + 6 mm (i.e. 4 mm oversized). For bolt diameters greater than 24 mm in oversized holes, thicker washers are necessary.

On the other hand, preload relaxation because of reduced bearing area under the bolt head is not an issue if a method of direct tensioning is used to tighten the bolts. Load indicating washers would provide such a method, but with enlarged holes such washers (which are usually used under the head of the bolt) would need the support of an additional plain washer.

The matter of reduced slip resistance due to excessive inter-ply contact pressure can only be controlled by limiting the amount of hole enlargement. It has been shown that for 24 mm diameter bolts this effect is not significant for over-sizing less than bolt diameter + 6 mm.

#### *Shear and bearing resistances*

Shear or bearing resistance will become important when slip has occurred up to the point where sufficient bolts come into bearing within the holes in the various piles.

In the event that some holes within that group are enlarged, the strength of the joint is a function of how many bolts can simultaneously come into bearing, each side of the joint being considered independently. This is affected by: the number of holes enlarged; the direction of enlargement in each hole; the amount of that enlargement; and the bearing capacities of the various plies within the joint.

Clearly, odd holes enlarged transversely present less of a problem when slippage occurs than holes enlarged longitudinally, provided that sufficient member cross sec-

tion remains. But it is not possible to give general advice on the proportion of holes within a joint that may be enlarged or by how much. Any joint which may require some hole enlargement to fit bolts should be assessed individually, taking into account the above factors.

EN 1993-1-8 gives rules for the reduction in slip resistance of joints with oversized holes, short slotted holes, and long slotted holes, but these rules were drafted for member joints where all the holes conform to one of the above categories, rather than the situation where a small proportion of the holes in the joint are enlarged.

Fabricators and erectors should not be permitted to ream any hole at will. However there will be times when it is to the advantage of all parties to overcome a particular problem by reaming some holes. To cover this situation it is suggested that specifiers require that reaming of bolt holes may only be carried out subject to notification and approval in each case

#### **Holes for bolts in weather resistant steel**

Preloaded bolts in weathering steel grade material (to be used with weathering steel girders) may not be available in metric sizes. It is recommended that the design be carried out assuming the use of metric M24 or M30 bolts but that the joint be detailed such that the slightly larger imperial 1" or 1¼" bolts can be substituted without compromising the hole spacing and edge distance limitations.

#### **References**

1. EN 1090-2:2008 - Execution of steel structures and aluminium structures – Part 2: Technical requirements for steel structures.
2. EN 1993-1-8: 2005 - Design of steel structures - Design of Joints.
3. EN1993-1-9: 2005 – Design of steel structures – Fatigue.



## The prefabrication meeting

No. 5.09

**Scope**

This Guidance Note suggests an outline agenda for a prefabrication meeting, usually attended by, as a minimum, a representative from the client, the contractor, and the steelwork contractor.

Where the Client or Contractor has employed a Designer to prepare a design, a representative from the design team may also be asked to attend.

In some circumstances, the Client or Contractor may also appoint an independent inspection authority to oversee some or all of the fabrication activity. In such cases, a representative of the appointed inspection authority would also attend, as would the inspector who will actually carry out any independent inspection work.

**The meeting**

At the commencement of a contract that involves the fabrication of bridge steelwork, the parties involved need to meet at an early stage to discuss the clarity of the contract provisions with respect to all the relevant technical issues.

The arrangements for carrying out the work need to be explained and recorded; access for inspection needs to be agreed; procedures for dealing with queries that arise need to be established.

An agenda that was drawn up by Messrs Sandberg for such initial meetings has been adopted within the steel bridge sector. A copy of that agenda is presented below, with a few additional points to cover increasing use of quality assurance schemes.

Careful consideration will need to be given to contractual arrangements encompassing quality management systems and agreed forms of self certification. This will need to cover input, if required, by the Designer and/or the inspector at clearly defined review stages, where necessary.

**Agenda**

- 1.0 Meeting details
  - 1.1 Purpose of meeting
  - 1.2 Agenda
  - 1.3 Official minutes
- 2.0 Fabrication programme
  - 3.0 Specifications for materials and workmanship
    - 3.1 Application code and British Standards
    - 3.2 Use of other specifications and certificates of conformity (where permitted)
  - 4.0 Sub-contracting
    - 4.1 Flame cutting
    - 4.2 Fabrication and welding
    - 4.3 Bending
    - 4.4 Machining
    - 4.5 Non-Destructive testing
    - 4.6 Destructive testing
    - 4.7 Protective treatment
    - 4.8 Site erection, welding, non-destructive testing and protective treatment
  - 5.0 Materials supply
    - 5.1 Material specifications/codes and steel grades
    - 5.2 Mills inspection
    - 5.3 Supply condition
    - 5.4 Supply by stockists
    - 5.5 Certificates of test
  - 6.0 Materials at Contractor's Works
    - 6.1 Contractor's quality management system for receipt
    - 6.2 Contractor's traceability system
    - 6.3 Certificates of test for Independent inspector's review
    - 6.4 Lamination checks
  - 7.0 Drawings
    - 8.0 Preparation of materials
      - 8.1 Flame cutting
      - 8.2 Preparation of edges, ends and surfaces
      - 8.3 Fitted stiffeners
      - 8.4 Holes for bolts
    - 9.0 Welding
      - 9.1 Welding procedure specifications
      - 9.2 Welding procedure approvals
      - 9.3 Welder approvals

# Guidance Note

## 5.09

---

- 9.4 Welding preparations
- 9.5 Temporary attachments
- 9.6 Welding distortion
- 9.7 Welding stud shear connectors
  
- 10.0 Bending
  
- 11.0 Straightening and flattening
  
- 12.0 Production test plates
- 12.1 Location and numbers of production test plates
- 12.2 Testing of production test plates
  
- 13.0 Non-destructive testing of welding
- 13.1 Methods of and areas requiring NDT for butt and fillet welds
- 13.2 Acceptance levels for NDT
- 13.3 NDT equipment calibration
- 13.4 NDT operator qualifications
- 13.5 NDT procedures
- 13.6 NDT reports
  
- 14.0 Testing of stud shear connectors
- 14.1 Ring testing
- 14.2 Bend testing
  
- 15.0 Tolerances
- 15.1 Tolerance requirements
- 15.2 Temporary erection at contractor's works
- 15.3 Fabricator's method for recording tolerance checks
- 15.4 Independent inspector checks
  
- 16.0 Bolts, nuts and washers
- 16.1 Preloaded fastener assemblies
- 16.2 Methods of tightening and pre-load control for preloaded bolts
  
- 17.0 Handling and stacking
  
- 18.0 Protective treatment
- 18.1 Protective treatment system
- 18.2 Paint manufacturer and paint data sheets
- 18.3 Paint storage
- 18.4 Testing of paints
- 18.5 Contractor's quality management system for painting
- 18.6 Painting environmental conditions
- 18.7 Painting procedure trial
- 18.8 Blast cleaning reference sample panel
- 18.9 Metal spray reference sample panel
- 18.10 Damage to protective treatment
- 18.11 Contact surfaces of slip resistant bolted joints
- 18.12 Independent inspector's involvement in protective treatment
  
- 19.0 General points
- 19.1 Facilities for Independent inspector.
- 19.2 Contractor's quality management documents review by Independent inspector
- 19.3 Contractor's quality plan
- 19.4 Inspector's quality plan
- 19.5 Inspector's unconfirmed reports
- 19.6 Independent inspector's contact with Client/Contractor/Designer
- 19.7 Procedure(s) for dealing with imperfections, defects and other non-conformities
  
- 20.0 Requirements for submission of records; identify records required, responsibility for collation and arrangements for submission.
  
- 20.1 Any special requirements or considerations

**Scope**

This Guidance Note gives general information about controlling the quality and inspection of welds in structural steelwork for bridges. The intention is to provide an appreciation of the factors that can influence weld quality, and the inspection practices currently used before and during welding that may be implemented during the fabrication and erection of bridge steelwork.

**Welding quality requirements**

The execution standard for steel structures EN 1090-2 (Ref.1) gives technical requirements for welding and these are supplemented by other documents necessary to specify fully the work to be carried out for the particular project. Designers and specifiers will normally include in this set of documents the Model Project Specification (MPS, Ref.2), modifying and completing it as necessary for the project.

Generally, EN 1090-2 requires that fusion welding shall be undertaken in accordance with the requirements of the relevant part of EN ISO 3834.

EN ISO 3834 comprises a number of parts that describe the requirements necessary to ensure that quality is achieved by control of manufacture: it is recognized that quality cannot be added after manufacture by an inspection procedure. The document deals with all aspects of welding, from a technical review of the requirements through planning and process control to inspection and testing and control of records.

For bridgework, EN ISO 3834-2 (Ref.3) is relevant and this specifies comprehensive requirements for controlling weld quality. There are many essential tasks to consider in welding, some practical influences are:

- Materials
- Preparation and fit-up conditions
- Welding procedures
- Welder approval
- Control of parameters before and during welding

**Materials**

Consideration must be given to the type and grade of material to be welded, particularly where additional properties such as toughness are specified. For carbon manganese steel, the carbon equivalent (CE) value is a measure of weldability. The CE, together with the combined thickness of the parent metal, heat input and the hydrogen content of the consumable, determines the preheat requirements for the weld necessary to avoid hydrogen cracking, although there are significant other considerations to take into account when assessing the overall risk. EN 1011-2 (Ref.4) Annexes C and D provide detailed guidance on avoiding hydrogen cracking and on heat affected zone toughness and hardness.

Inspection certificates for steel must be authenticated to verify the applicable standard and relevant material grade. All principal steelwork including flanges, webs, stiffeners, diaphragm plates, bracing members, cover plates, etc., should be traceable to material inspection certificates throughout the fabrication process. The MPS describes a practical approach to piece, type or stock traceability.

**Preparation and fit-up conditions**

The successful deposition of a satisfactory weld is dependent on the preparation and fit-up conditions. A correctly prepared and assembled joint should enable the welding operative to deposit a satisfactory weld.

Normally, weld preparation and fit-up conditions for both butt and fillet welds should be in accordance with the Welding Procedure Specification (WPS), although additional tolerances such as those given in the applicable welding application standard (usually EN 1011) may apply. Examples of preparation and fit-up conditions for a typical flange to web fillet weld joint are shown in Figure 1 and for a typical asymmetric double V flange plate butt joint welded from both sides in Figure 2. Note that for fillet welds, any increase in the root gap requires a proportionate increase in leg length of the fillet weld in order to maintain the effective design throat thickness of the fillet weld. See GN 5.01 for more information on joint preparation and fit up considerations.



# Guidance Note

## No. 6.01

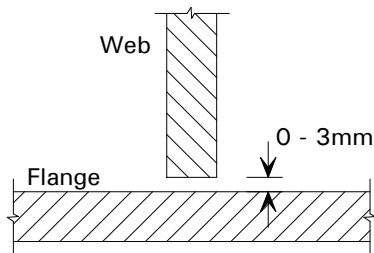

**Figure 1** Typical flange to web fillet weld joint

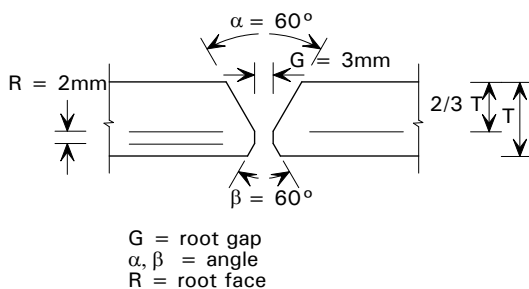

**Figure 2** Typical asymmetric double V flange plate butt weld joint

Weld preparations should be examined visually and checked dimensionally using a suitable gauge capable of measuring bevel angle, root face and root gap. Preparations range from simple flange-to-web fillet welded joints as in Figure 1 and in-line butt welds in plated girders as in Figure 2, to more complex cruciform joints and corner connections in box girders.

Whilst inspection of the fit-up conditions and weld preparations on most connections is usually examined on a random basis, it is prudent to inspect the assembly of all critical joints such as tension flange butt welds, fitted bearing stiffeners etc. Weld preparations and fit-up conditions that do not comply with the relevant WPS or the tolerances given in the application standard must be rectified.

### Welding procedures

Welds can be deposited using a variety of processes including:

- submerged arc welding (SAW)
- gas shielded metal arc welding (MAG or FCAW)
- manual metal arc welding (MMA)

Of these, SAW and MAG are the most commonly used in the fabrication of steelwork for bridges. Cored wires are increasingly being used, particularly because of the higher deposi-

tion rates, positional versatility and the ability of the flux to influence the weld chemistry. MMA welding is used generally for site work. Examples of their use are shown in Figure 3. Summary descriptions of the processes are given in GN 3.04.

In order to ensure that the quality of the deposited weld metal is to an acceptable standard, welding must be carried out in accordance with a suitably approved WPS drafted in accordance with EN 15609-1 (Ref 5). Such a specification is normally based on a scheme specific or prequalified Welding Procedure Qualification Record (WPQR) in accordance with EN 15614-1 (Ref.6). Procedures approved in accordance with former standards or specifications, e.g. EN 288-3, are not invalidated by the issue of this standard, provided that technical requirements are equivalent. GN 4.02 describes in more detail welding procedure testing and the formulation of WPS based upon the ranges of qualification.

During production welding, parameters should be set within the ranges established during qualification of the welding procedure, taking account of welding position, preparation and fit-up conditions.

### Welder approval

Another important aspect of welding is to monitor the competence of individual welders or machine operators. The requirement for qualification or approval testing is prescribed in specifications and standards but the success of all welding projects relies heavily on the workforce having appropriate training.

Qualification testing for bridgework in the UK is normally carried out in accordance with the requirements of EN 287-1 (Ref.7). The standard prescribes tests to be conducted to approve welders for process, type of joint, position and material.

### Control before and during welding

Maintaining control before and during welding is essential to achieve a successful result. EN ISO 3834-2 defines the in-process inspections and tests necessary.

Prior to welding it is important that welding consumables are as stated on the WPS and

that they have been stored in accordance with the manufacturer's recommendations. In addition, any other requirements of the WPS must be implemented, for example, application of preheat and any distortion control measures.

To ensure that parameters are controlled satisfactorily during welding, it is essential that welding plant is serviced and calibrated, so that the equipment settings can be adjusted accurately. Periodic checks should be made during production welding using calibrated meters to confirm that the essential parameters stated in the WPS, including current, voltage, travel speed etc. are adhered to and welding consumables are correctly used and handled. Preheat should be maintained throughout the welding processes and where appropriate interpass temperature monitored. Attention should be paid to the welding sequence, the cleaning and shape of runs and layers, the profile and integrity of back-gouged butt welds. Intermediate checking of dimensions may justify a change of strategy and it is sometimes prudent to modify the welding sequence to balance weld shrinkage and control distortion. Additional precautions may be necessary because of environmental conditions, for example during site welding operations.

#### **Inspection and testing after welding**

Welding is not perfect: following deposition, a weld may contain imperfections or discontinuities. Unacceptable imperfections (defects) prevent the weld from developing the strength or fatigue life intended by the designer. Imperfections may be visible on the surface of the weld, or they may be sub-surface, embedded within an otherwise visually satisfactory weld. The detection and sizing of imperfections are dependent on the inspection methods and the extent of testing specified in the application standard or contract. It should be appreciated that with non-destructive examination it is not possible to detect, characterize and size all the imperfections that may be present in the weld.

What is important is whether any imperfections that exist in the welded components are likely to affect the satisfactory performance of the structure, i.e. to affect its 'fitness-for-purpose'. If they do, they should be considered to be defects and repaired accordingly.

In practice, quite large imperfections (either a few large isolated ones or numerous small ones) can exist without compromising the static ultimate strength of the element or structure. However, imperfections can have a greater effect on fatigue strength, since they can grow as a result of cyclic loading. The level of imperfection that can be tolerated in a welded detail therefore depends on the fatigue loading that the welded detail is required to endure. An effective testing regime and quality acceptance specification will seek to determine what level of imperfection exists, and then judge whether these will impair the fitness-for-purpose of the structure. To call for the repair of imperfections that do not reduce fitness-for-purpose is not only an unnecessary waste of time and resources, but introduces other imperfections, often large enough to be defects, in the course of repair.

Various inspection and test methods are used to ensure the integrity of completed welds and are described in other Guidance Notes. The visual inspection of welds is described in GN 6.06. Non-destructive testing techniques such as the surface inspection of welds using magnetic particle testing (MT or MPI) and penetrant testing (PT), and the sub surface inspection of welds using ultrasonic testing and radiography, are the subjects of GN 6.02 and GN 6.03 respectively.

#### **Acceptance criteria**

Generally, acceptance criteria for all aspects of the execution of steelwork are given in EN 1090-2 in relation to the 'execution class'. Four classes are defined and the MPS says that class EXC3 is appropriate for most bridge steelwork.

The quality of production welds is specified in terms of weld acceptance levels. For each form of imperfection these will place limits on the occurrence or maximum dimension of the imperfection. For EXC3 welding quality is specified as Quality Level B to EN ISO 5817 (Ref.8). Any additional requirements for weld geometry and profile need to be specified (see MPS 7.602 and GN 6.06).

If a higher quality level is required, for example where joints are required to have an enhanced design fatigue strength, this should be specified for each relevant joint detail and the extent

# Guidance Note

## No. 6.01

and method of testing can be selected to detect imperfections and to characterize them. The MPS provides a vehicle for specifying the extent of supplementary NDT and more stringent acceptance criteria. GN 6.02 and GN 6.03 provide further information.

The results from inspections should be recorded formally in a report giving details of the items examined, weld identification, acceptance criteria, reference to the procedure used, together with the results of any visual inspection carried out.

**Welding coordination and inspection personnel**  
EN ISO 3834-2 requires that welding coordination personnel shall be responsible for the quality activities associated with welding and such persons shall have sufficient authority to enable any necessary action. For the grade and thickness of materials used in bridges welding coordination personnel should have a compre-

hensive knowledge of welding as defined in EN ISO 14731 (Ref.9).

All inspection to ensure the quality of the completed welding shall be carried out by appropriately qualified and experienced personnel as required by EN 3834-2. Non-destructive testing, such as ultrasonic testing or MT should be performed by personnel qualified in accordance with EN 473 (Ref.10).

In many cases, the services of an independent testing organization will be engaged, in addition to the inspection carried out by the fabricator. This independent organization will normally place an inspector at the works on a full- or part-time basis to monitor the inspection carried out by the fabricator as part of the production process, and also to carry out verification testing in parallel.

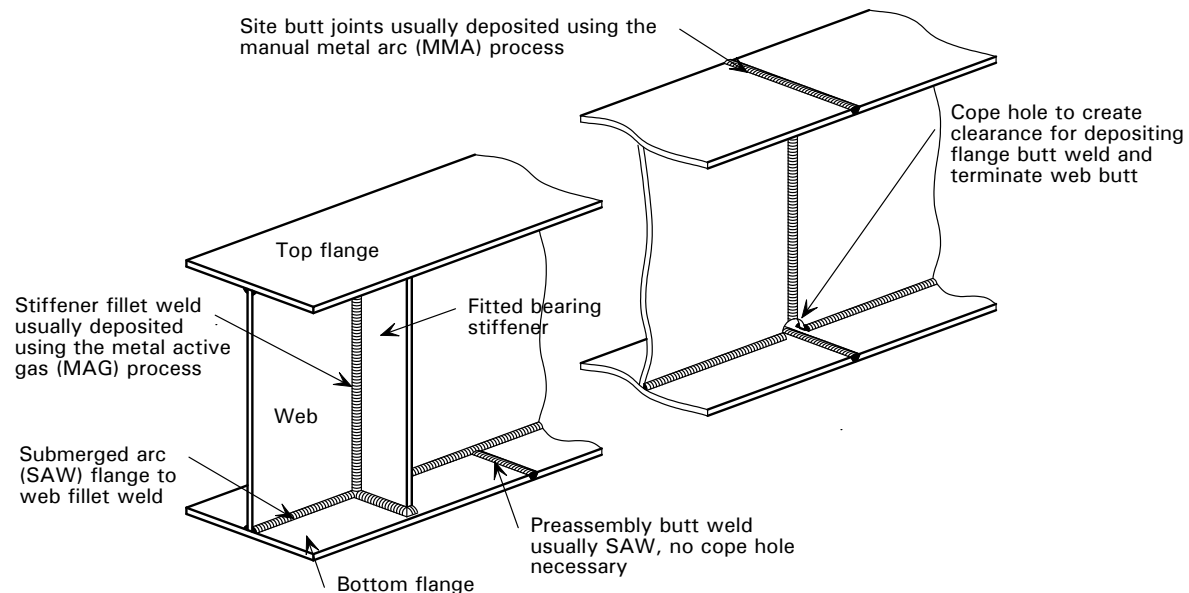

**Figure 3** Use of SAW and MMA in bridge steelwork

### References

1. EN 1090-2: 2008 Execution of steel structures and aluminium structures. Technical requirements for steel structures.
2. Steel Bridge Group: Model Project Specification for the execution of steelwork in bridges (P382), SCI, 2009.
3. EN ISO 3834-2: 2005 Quality requirements for fusion welding of metallic materials – Part 2: Comprehensive quality requirements.
4. EN 1011, Welding. Recommendations for welding of metallic materials  
Part 1: 1998, General guidance for arc welding  
Part 2: 2001, Arc welding of ferritic steels.
5. EN ISO 15609-1: 2004, Specification and qualification of welding procedures for metallic materials. Welding procedure specification. Arc welding.
6. EN ISO 15614-1: 2004, Specification and qualification of welding procedures for metallic materials. Welding procedure test. Arc and gas welding of steels and arc welding of nickel and nickel alloys.
7. EN 287-1: 2004 Qualification test of welders. Fusion welding. Steels.
8. EN ISO 5817: 2003, Welding. Fusion-welded joints in steel, nickel, titanium and their alloys (beam welding excluded). Quality levels for imperfections.
9. EN ISO 14731: 2006 Welding coordination – Tasks and responsibilities.
10. EN 473: 2008 Non-destructive testing – Qualification and certification of NDT personnel – General principles.



## Surface inspection of welds

No. 6.02

**Scope**

This Guidance Note applies to all welds in structural steelwork for bridges. It covers the surface inspection of welds using non-destructive techniques, either magnetic particle testing or, to a lesser extent, penetrant testing. Visual inspection and measurement of fusion welded joints after welding is covered in GN 6.06, and sub-surface inspection is covered in GN 6.03.

**Magnetic particle testing**

Magnetic particle testing or inspection (usually abbreviated MT or MPI) is a method of detecting surface or near-surface discontinuities or imperfections in ferro-magnetic materials by the generation of a magnetic flux within a component, and the application of suitable ferromagnetic particles to its surface so as to render the imperfection visible. In principle, the steel surface (including the weld) is magnetized to induce a magnetic flux within the material; the distribution of this flux is disturbed by the presence of imperfections which cause some flux leakage from the surface of the steel. The magnetic field is usually produced by low voltage magnetizing currents introduced into the steel between two electro-magnets, as shown in Figure 1.



**Figure 1** Setup for MPI

Magnetic powder or flaw detection ink with ferromagnetic particles is applied to the surface whilst magnetized. The ferromagnetic particles are attracted and retained by the flux leakage and thus delineate the imperfection. Imperfections are measured and assessed against the workmanship standard and unacceptable imperfections are declared defects.

Magnetic particle testing can detect cracks, non-metallic inclusions and other imperfections

on or near the surface of the steel. The sensitivity of the inspection is not greatly impaired by the presence of foreign matter in the imperfection, and it is possible to inspect components that have been treated with a non-magnetic coating up to 50  $\mu\text{m}$  thick. Maximum sensitivity is achieved when the imperfection lies at right angles to the magnetic field, but is not reduced below the effective level if the imperfection is orientated at an angle of up to 45° from the optimum direction. To obtain the best sensitivity the magnetic field has to be passed in two directions at right angles to each other, in separate operations. Surface cracks produce the sharpest delineation, whilst imperfections just below the surface produce less well-defined indications, making interpretation of test results difficult. Abrupt changes in geometry (sharp corners, edges, excessive surface roughness) and change in magnetic permeability in the heat affected zone of the weld may give indications that can be mistaken for defects.

Note that many specifiers prohibit the use of current flux prods. Electro magnets are now favoured because they eliminate the potential of arcing to steel that exists with current flux prods.

**Penetrant testing**

Penetrant testing (abbreviated to PT) is a process for detecting certain imperfections open to the surface.

The basis of penetrant testing is that liquid penetrant applied to the surface to be examined enters (through capillary action) any crack or imperfection open to the surface. After a period of soaking, the surplus liquid is removed, either by washing or application of a solvent (depending on the type of penetrant), and a developer is applied. This causes the liquid left in the crack to be drawn to the surface and make it show visibly. Usually colour-contrast dye penetrant is used, rather than fluorescent penetrant. Wide cracks produce a seepage or spread of the penetrant, whilst fine cracks often appear as a series of dots in line which in time may link up to give a continuous line. Rounded surface imperfections are easily recognizable because of the penetrant spread.

# Guidance Note

## No. 6.02

---

It should be noted that some of the materials used can be toxic, and that adequate control of effluent has to be provided.

### Scope of inspection

The standard applicable to the execution of steel structures, including bridges, is EN 1090-2 (Ref 1). Workmanship, inspection and testing requirements are defined according to the 'execution class'. Designers and specifiers will normally adopt requirements from the Model Project Specification (MPS, Ref 2) as part of the execution specification; the MPS says that class EXC3 is appropriate for bridges. The inspection and testing regime for this execution class is defined in EN 1090-2.

For new welding procedure specifications, a more stringent testing regime is applied to the first 5 joints tested to establish that the WPS produces conforming quality welds when implemented in production.

Visual examination is always required, followed by an amount of supplementary non-destructive testing specified in EN1090-2 clause 12.4.2.2 and Table 24. Table 23 in the Standard defines minimum hold times after welding before supplementary NDT takes place. The extent of testing for surface and internal imperfections is given for various joint types and Execution Class.

EN 1090-2 also provides for the execution specification to identify specific joints for inspection together with the extent and method of testing. This is to accommodate more stringent examination when fatigue strength requirements are higher.

Where partial or percentage examination is specified, guidance on selection of test lengths is given in EN 12062 (Ref 3) Annex C. EN 1090-2 also states that sampling should cover as widely as possible, joint type, material grade, welding equipment and the work of the welders.

EN 12062 Annex D provides guidance on additional examination procedures where non-acceptable indications are revealed.

### Method of non-destructive testing

EN 1090-2 states that the method of NDT shall be selected from those described in EN 12062 by personnel qualified to Level 3 as defined in EN 473 (Ref 4). It suggests that penetrant or magnetic particle testing are suitable methods for testing fillet welds for surface imperfections. For bridges in conventional structural steels, MT is the principal method in use by UK steelwork contractors.

The use of MT may also be specified on the tensile surface when plates have been bent, to verify the absence of surface cracks. In addition, it is used for assessing the integrity of backgouged root areas and excavated repairs.

Penetrant testing is a time consuming process and it is normally used on bridges for testing joints in special machined components or non-magnetic steels, such as austenitic stainless steels, used on feature pieces or perhaps handrailing. It is also used for testing joints in dissimilar materials, for example, austenitic stainless steel to mild steel, although this type of joint should only be used for non-structural elements, such as drains and architectural features.

EN 12062 states that magnetic particle testing of welds shall be carried out in accordance with EN 1290 (Ref 5) and penetrant testing shall be carried out in accordance with EN 571-1 (Ref 6). The standards describe the equipment, techniques, surface preparation and viewing conditions necessary to carry out the test. It also describes the information to be included in the test report.

### Acceptance criteria

EN 1090-2 requires that for EXC3 joints the acceptance criteria for weld imperfections is Quality Level B to EN ISO 5817 (Ref 7).

For joints where an enhanced level of quality is required to meet design fatigue strength requirements, EN 1090-2 Table 17 gives additional requirements for class EXC4 as Quality Level B+. In addition, the table gives supplementary requirements for bridge deck steelwork. These are more stringent acceptance standards for imperfection types over and above Quality Level B.

Generally the requirements for Quality Level B+ are not practically achievable in routine production. Indeed normal welding procedure and welder qualification tests are not assessed against acceptance criteria at this level. If a higher quality level is required, this should be specified for each relevant joint detail and the extent and method of testing can be selected to detect imperfections and to characterize them. The MPS provides a vehicle for specifying the extent of supplementary NDT and more stringent acceptance criteria.

EN 1090-2 suggests that non-conforming welds be judged individually for each case and evaluation should be based on the function of the component and the characteristics of the defect in terms of type, size and location in order to determine acceptability. Reference back to the design codes may be used to support the evaluation.

Surface breaking cracks are not permitted. Other imperfections can be accepted subject to certain limitations on dimension and location which safeguard against the initiation and propagation of cracks in fatigue sensitive areas.

Temporary attachments should be removed and weld areas carefully ground smooth; EN 1090-2 requires inspection of areas from which temporary attachments have been removed to ensure there is no surface cracking. The MPS specifies magnetic particle testing for this.

The designer should be aware that imperfection types, such as internal pores and solid inclusions in fillet welds are not detectable using normal surface examination techniques used in bridgework. See GN 6.03 for further advice on sub-surface inspection.

### Repair

Where testing identifies defects, repair becomes necessary. In some cases this might involve a simple localized light grinding or dressing to correct the problem and it is not practical to report these.

For more substantial repairs, which are reported through non-conformance and corrective action procedures, the repair is likely

to involve gouging and welding. It is necessary to maintain control by implementing a repair procedure either of a generic nature or specifically developed to correct the problem. In either case, the completed repair area needs re-examination and reporting.

### Non-destructive testing personnel

All inspection to ensure the quality of the completed welding should be carried out by appropriately qualified and experienced personnel as required by EN 3834-2 (Ref 8). Non-destructive testing, such as MT should be performed by personnel qualified in accordance with EN 473.

### Surface penetrating defects

Magnetic particle testing (and also penetrant testing) is normally used to detect surface penetrating cracks and surface breaking porosity in butt and fillet welds. Porosity is created when gas is entrapped in solidifying weld metal, and is a sign that the welding process has not been properly controlled or that the base metal is contaminated or of variable composition. The presence of porosity indicates that there is the possibility of hydrogen in the weld and heat affected zone (HAZ) that may lead to cracking. Porosity may occur as:

- a localized cluster of pores usually resulting from improper initiation or termination of the welding arc;
- a line of pores aligned along a joint boundary, the root of the weld, or an inter-bead boundary caused by contamination that leads to gas evolution within the weld;
- one or two surface imperfections which may be interspaced with many more sub-surface elongated cavities or wormholes (also known as piping porosity).

Cracks occur in the weld and/or base metal when localized stresses exceed the ultimate strength of the material. Generally high residual stresses are present, and crack initiation and propagation is greatly influenced by the presence of imperfections that concentrate stress. Hydrogen embrittlement is often a contributor to crack formation - see GN 6.04 for further guidance. Welding related cracks are generally brittle in nature, exhibiting little plastic deformation at the crack boundaries.



# Guidance Note

## No. 6.02

Longitudinal cracks are parallel to the axis of the weld (Figure 2). They can be:

- throat cracks, generally found in the centre of the weld bead and usually, but not always, hot cracks forming upon the solidification of the weld metal at temperatures near the melting point;
- root cracks, generally hot cracks in the root of the weld;
- toe cracks propagating into the base metal from the toe of the weld where restraint stresses are highest; these are hydrogen-induced cold cracks, forming hours or days after the completion of welding (see GN 6.04).

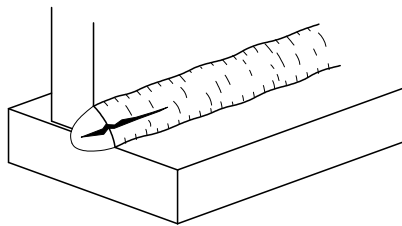

**Figure 2** Longitudinal crack in face of weld

In submerged arc welds made by semi- or fully automatic welding process, longitudinal cracks are often associated with high welding speeds. In small welds between heavy sections, longitudinal cracks often result from fast cooling rates and high restraint and are usually associated with an inappropriate weld depth to weld width ratio.

Transverse cracks are orthogonal to the axis of the weld (Figure 3). They occur in the weld metal, the base metal or both. Transverse cracks initiating in the weld metal are commonly the result of longitudinal shrinkage stresses acting on excessively hard weld metal.

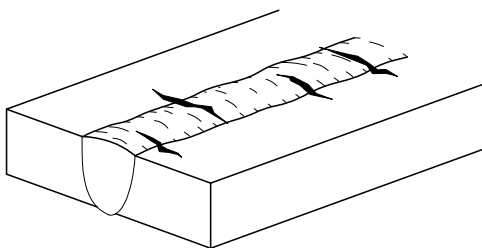

**Figure 3** Transverse surface crack

Transverse cracks initiating in the HAZ are generally hydrogen cracks.

Crater cracks form in the crater or depression that is formed by improper termination of the welding arc. Usually they are shallow hot cracks in the form of a multi pointed starlike cluster (Figure 4).

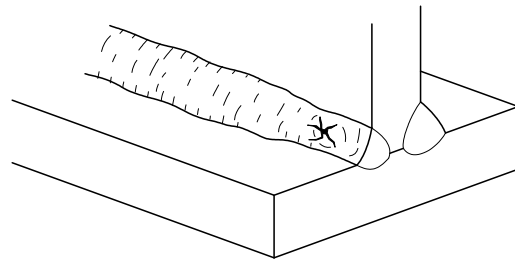

**Figure 4** Crater crack in fillet weld

For further information on imperfections in metallic fusion welds, refer to EN ISO 6520 (Ref 9).

### References

1. EN 1090-2: 2008 Execution of steel structures and aluminium structures. Technical requirements for steel structures.
2. Steel Bridge Group: Model Project Specification for the execution of steelwork in bridges (P382), SCI, 2009.
3. EN 12062: 1998 Non-destructive examination of welds. General rules for metallic materials.
4. EN 473: 2008 Non-destructive testing – Qualification and certification of NDT personnel – General principles.
5. EN 1290: 1998 Non-destructive testing of welds. Magnetic particle testing of welds.
6. EN 571-1:1997 Non-destructive testing. Penetrant testing. Part 1 General principles.
7. EN ISO 5817: 2003 Welding. Fusion-welded joints in steel, nickel, titanium and their alloys (beam welding excluded). Quality levels for imperfections.
8. EN ISO 3834-2: 2005 Quality requirements for fusion welding of metallic materials. Part 2: Comprehensive quality requirements.
9. EN ISO 6520-1: 1998 Welding and allied processes. Classification of geometric imperfections in metallic materials. Fusion welds.

**Scope**

This Guidance Note applies to all welds in structural steelwork for bridges. It covers the sub-surface inspection of welds using ultrasonic inspection testing and radiographic inspection. Visual inspection and surface inspection are covered in GN 6.06 and 6.02 respectively.

**Ultrasonic testing**

Ultrasonic testing (frequently abbreviated to UT) uses ultrasound to detect sub-surface imperfections (also termed embedded discontinuities) in the weld and the parent metal. A soundwave transmitted through the steel by a surface mounted probe is reflected back by any boundary or intervening imperfection. A signal on the screen of the flaw detector shows the time the sound wave takes to travel from the far boundary; where an imperfection is present it shows the shorter time for the signal to travel back from the imperfection.

The amplitude of a reflected signal from a imperfection depends on the form of the imperfection, whether it is rounded or planar. An imperfection near to the probe will give a greater response than a imperfection of the same size further away. With planar imperfections such as cracks, lack of penetration and lack of sidewall fusion, the amplitude of the signal is related not only to the shape but also to its orientation and the nature of the reflecting surface. The angle of the probe to the imperfection has to be selected to obtain maximum response. Imperfections are measured and assessed against the limiting values and unacceptable imperfections are declared defects.

Ultrasonic testing is a portable and easily applied process, unlike radiography which is now little used in the industry due to health and safety concerns relating to radiation. The method has a sensitivity adequate for the normal range of thicknesses used in structural steelwork. It should not normally be used for plate thicknesses less than 8 mm. UT can detect the most common imperfections found in welding and can be sensitive to those that are too small to be detrimental to the soundness of the weld, whereas radiography may not detect certain types of imperfection or be capable of accurate sizing.

Ultrasonic testing may also be used on areas of plates where the designer has specified limits on laminar defects (see GN 3.02).

**Radiographic inspection**

Radiographic inspection, (also called radiography) uses a beam of penetrating ionizing radiation, usually from an X-ray or gamma-ray source, to detect sub-surface imperfections in the weld and the parent metal. In general, a gamma-ray technique will be less sensitive than an X-ray technique for penetrated thicknesses between 10 mm and 50 mm. A weldment in the path of a beam of penetrating ionizing radiation absorbs the radiation as it passes through the material. Any imperfection present will cause a difference in density of the material and thus the absorption in the imperfection area will differ from that in the surrounding area. This change in absorption is detected by placing a photographic film on the far side of the weldment from the radiation source. The photographic image produced by the beam of penetrating ionizing radiation is called a radiograph. The flaw detection capability of a radiographic technique increases as the graininess of the film is reduced and is also dependent on the film-screen combination.

Radiography has been used in cases of dispute to clarify the nature, sizes or extent of flaws detected ultrasonically. This may be required where UT gives indications of sub-surface imperfections. However, unless planar flaws are favourably oriented to the beam, the result may not necessarily be conclusive. Unlike the UK, in the USA and many other countries outside Europe, radiography is the preferred method for the detection of sub-surface flaws, primarily because the radiograph is seen as providing a permanent record of the evidence of the flaw which is readily understood even though interpretation is subjective.

**Scope of inspection**

The standard applicable to the execution of steel structures, including bridges, is EN 1090-2 (Ref 1). Workmanship, inspection and testing requirements are defined according to the 'execution class'. Designers and specifiers will normally adopt requirements from the Model Project Specification (MPS, Ref 2) as part of the execution specification; the MPS says that class EXC3 is appropriate for bridges.

# Guidance Note

## No. 6.03

---

The inspection and testing regime for this execution class is defined in EN 1090-2.

For new welding procedure specifications, a more stringent testing regime is applied to the first 5 joints tested to establish that the WPS produces conforming quality welds when implemented in production.

Visual examination is always required, followed by an amount of supplementary non-destructive testing described in EN 1090-2 Table 24. Table 23 in the Standard defines minimum hold times after welding before supplementary NDT takes place. The extent of testing for internal imperfections is given for various joint types and execution class.

EN 1090-2 also provides for the execution specification to identify specific joints for inspection together with the extent and method of testing. This is to accommodate more stringent examination when fatigue strength requirements are higher.

Where partial or percentage examination is specified, guidance on selection of test lengths is given in EN 12062 (Ref 3) Annex C. EN 1090-2 also states that sampling should cover as widely as possible, joint type, material grade, welding equipment and the work of the welders.

EN 12062 Annex D provides guidance on additional examination procedures where non-acceptable indications are revealed.

### **Method of non-destructive testing**

EN 1090-2 states that the method of NDT shall be selected from those described in EN 12062 by personnel qualified to Level 3 as defined in EN 473 (Ref 4). It suggests that radiography or ultrasonic testing are suitable methods for testing butt welds for internal imperfections. Knowledge of the weld preparation and size, and the most likely type of imperfection that the welding process may produce, is essential so that the correct examination methods are employed.

For bridges in conventional structural steels, UT is the principal method in use by UK steelwork contractors.

EN 12062 states that ultrasonic testing shall be carried out in accordance with EN 1714 (Ref 5). For the Quality Level applicable to

EXC3 joints described below, the examination technique and level shall be at least B in accordance with Annex A of EN 1714.

Radiographic examination of welds should be carried out in accordance with one or more of the appropriate techniques given in EN 1435 (Ref 6). The choice of radiographic technique shall be defined by the specification.

### **Acceptance criteria**

EN 1090-2 requires that for EXC3 joints the acceptance criteria for weld imperfections is Quality Level B to EN 5817 (Ref 7).

For joints where an enhanced level of quality is required to meet design fatigue strength requirements, EN 1090-2 Table 17 gives additional requirements for class EXC4 as Quality Level B+. In addition the table also gives further supplementary requirements for bridge deck steelwork. These are more stringent acceptance standards for several imperfection types over and above Quality Level B.

Generally the requirements for Quality Level B+ are not practically achievable in routine production. Indeed, normal welding procedure and welder qualification tests are not assessed against acceptance criteria at this level. If a higher quality level is required, this should be specified for each relevant joint detail and the extent and method of testing can be selected to detect imperfections and to characterize them. The MPS provides a vehicle for specifying the extent of supplementary NDT and more stringent acceptance criteria.

EN 1090-2 suggests that non-conforming welds be judged individually and evaluation should be based on the function of the component and the characteristics of the defect in terms of type, size and location in order to determine acceptability. Reference back to the design codes may be used to support the evaluation.

The designer should be aware that internal imperfection types, such as sub-surface porosity and solid inclusions in small fillet welds are not detectable using specified examination techniques such as ultrasonic testing as used in bridgework. Table 24 applies supplementary NDT to transverse fillet welds in tension or shear and the frequency of test is varied de-

pending upon the throat thickness and thickest material being joined. Standards do not prescribe a method for the examination of small fillet welds for sub-surface imperfections because the complexity and limitations of ultrasonic testing increase as the size of the fillet weld decreases. Most bridgework fillet welds are usually of less than 12 mm leg length, and are therefore too small to be tested using ultrasonic techniques. The advice of specialists should be sought if supplementary ultrasonic testing is required on fillet welds.

### Repair

Where testing identifies defects, repair may become necessary. Sub-surface repairs should be reported through non-conformance and corrective action procedures. The repair is likely to involve gouging and welding and it is necessary to maintain control by implementing a repair procedure either of a generic nature or specifically developed to correct the problem. In either case, the completed repair area needs re-examination and reporting.

### Non-destructive testing personnel

All inspection to ensure the quality of the completed welding should be carried out by appropriately qualified and experienced personnel as required by EN 3834-2 (Ref 8). Non-destructive testing, such as UT should be performed by personnel qualified in accordance with EN 473.

The successful application of manual ultrasonic testing depends on the knowledge and experience of the personnel responsible for producing the test procedures, and the competence and ability of the ultrasonic practitioner to carry out the procedural requirements and interpret the results.

The operator must be skilled in calibrating the flaw detector, able to recognize the significant characteristics of the echo-dynamic patterns of different types of imperfection, and be able to report the results for each weld examined.

### Sub-surface defects

The most common types of sub-surface defects that can occur as a result of the welding process are:

- Sub surface porosity.
- Inclusions.

- Lack of fusion.
- Lamellar tears.
- Sub surface cracks.

**Porosity** (also termed gas cavities) is created when gas is entrapped in the solidifying weld metal, and is a sign that the welding process has not been properly controlled, or that the base metal is contaminated or of variable composition. The presence of porosity indicates that there is the possibility of hydrogen in the weld and heat affected zone (HAZ) that may lead to cracking. Sub-surface porosity may be a number of gas pores either uniformly distributed throughout the weld metal or in a cluster, a large elongated cavity with its major dimension aligned with the axis of the weld, or a cluster of worm holes (also known as piping porosity).

**Inclusions** are solid foreign substances entrapped in the weld metal. The foreign substance may be non-metallic slag, flux, metallic oxide, or copper. In general, slag inclusions result from faulty welding technique, failure to clean properly between welding passes, and conditions that lead to limited access for welding within the joint. Usually the molten slag will float to the top of the weld, but sharp notches in boundaries or between passes can cause slag to be entrapped under the molten weld metal. Metallic oxides result from welding over unclean steel or weld metal. If the electrode holder is dipped in the molten weld metal or if the current is set too high, droplets of copper may be transferred to the weld metal. Inclusions are detectable by UT and radiography.

**Lack of fusion** between weld metal and parent metal, or between weld metal and weld metal, may result from improper welding techniques or preparation of the metal for welding. Deficiencies causing lack of fusion (also termed incomplete fusion) include insufficient welding heat, improper electrode manipulation and lack of access to all boundaries that are to be fused during welding. Tightly adhering oxides may prevent complete fusion even when there is access and proper procedures are used. Lack of penetration (also termed incomplete penetration) is the lack of fusion between parent metal and parent metal due to failure of the weld metal to extend into the root of the joint. Lack

# Guidance Note

## No. 6.03

---

of fusion is detectable by UT and sometimes by radiography.

**Lamellar tears** are planar separations in the base metal adjacent to the HAZ caused by thermally induced shrinkage stresses in the through thickness direction resulting from welding. Tears are generally parallel to the surface of rolled products, and the fracture usually propagates from one plane to another on shear planes normal to the rolled surface. Specification of steel of proven through thickness properties for cruciform, T and corner joints when the total weld throat on any one surface exceeds 35 mm for a T-joint or 25 mm for a corner joint should be considered to avoid this problem (see GN 3.02). Lamellar tears are detectable by UT but not by radiography.

**Cracks** occur in the weld and/or base metal when localized stresses exceed the ultimate strength of the material. Generally high residual stresses are present and crack initiation and propagation is greatly influenced by the presence of imperfections that concentrate stress. Hydrogen embrittlement is often a contributor to crack formation - see GN 6.04 for further guidance. Welding related cracks are generally brittle in nature, exhibiting little plastic deformation at the crack boundaries. Cracks are not detectable by radiography, unless very large.

Longitudinal cracks are parallel to the axis of the weld. They can be:

- throat cracks (otherwise known as centre-line or solidification cracks); these are generally found in the centre of the weld bead and are usually, but not always, hot cracks, formed on the solidification of the weld metal at temperatures near the melting point;
- root cracks; these are generally hot cracks in the root of the weld;
- toe cracks, propagating into the base metal from the toe of the weld where restraint stresses are highest; these are cold cracks forming hours or days after the completion of welding;
- hydrogen-induced heat affected zone cracks; these are cold cracks, generally short, although they may join to form larger continuous cracks, which align themselves

with weld boundaries that concentrate residual stress.

In submerged arc welds made using the semi- or fully automatic welding process, longitudinal cracks are often associated with high welding speeds. In small welds between heavy sections, longitudinal cracks often result from fast cooling rates and high restraint.

Transverse cracks are orthogonal to the axis of the weld. They occur in the weld metal, the base metal or both. Transverse cracks initiating in the weld metal are commonly the result of longitudinal shrinkage stresses acting on excessively hard weld metal. Transverse cracks initiating in the HAZ are generally hydrogen cracks.

For further information on imperfections in metallic fusion welds, reference should be made to EN ISO 6520 (Ref 9).

### References

1. EN 1090-2: 2008 Execution of steel structures and aluminium structures. Technical requirements for steel structures.
2. Steel Bridge Group: Model Project Specification for the execution of steelwork in bridges (P382), SCI, 2009.
3. EN 12062: 1998 Non-destructive examination of welds. General rules for metallic materials.
4. EN 473: 2008 Non-destructive testing – Qualification and certification of NDT personnel – General principles.
5. EN 1714: 1998 Non-destructive testing of welds. Ultrasonic testing of welded joints.
6. EN 1435: 1997 Non-destructive examination of welds. Radiographic examination of welded joints.
7. EN ISO 5817: 2003 Welding. Fusion-welded joints in steel, nickel, titanium and their alloys (beam welding excluded). Quality levels for imperfections.
8. EN ISO 3834-2: 2005 Quality requirements for fusion welding of metallic materials. Part 2: Comprehensive quality requirements.
9. EN ISO 6520-1:1998 Welding and allied processes. Classification of geometric imperfections in metallic materials. Fusion welding.

## Hydrogen/HAZ cracking and solidification cracking in welds

---

No. 6.04

### Scope

This Guidance Note gives information about a particular aspect of welding; the tendency for cracks to develop in the weld or the heat affected zone (HAZ) that would impair structural effectiveness and which could lead to failure.

### Background

While the first welded bridge was constructed in the UK in the 1930's, the first British Standard on the subject was not published until the 1950's and its content was very basic. BS 5135, first published in 1974, was the first comprehensive standard on the subject and it included guidance on the avoidance of hydrogen cracking. That Standard has now been superseded and guidance on the avoidance of hydrogen cracking is now given in BS EN 1011-2.

Along the way many problems have been encountered and much research has been carried out. Welding is now one of the most widely used industrial processes and many excellent and extensive texts exist covering the jointing of many and various materials.

The problems are now very well understood, but for a busy supervising civil engineer not specializing in this area, there are few of these texts which give a simple insight to the basic issues which affect bridge construction.

This Note seeks to give that insight and put the reader in a position where some of the more complicated issues are perhaps not so daunting. Only the basic metallurgical issues are considered.

### Hydrogen/HAZ cracking

The molten metal in a weld pool can take surprising amounts of hydrogen into solution from moisture and the atmosphere (see below). On cooling and solidification of the weld metal, hydrogen comes out of solution and migrates, some to atmosphere, but most across the fusion boundary of the weld into the parent metal.

If the metal in the heat affected zone (HAZ) of the parent metal, adjacent to the weld pool, has not become significantly hard during the welding process, then there is no particular

problem. However, if significant hardness exists, the material in this region is more susceptible to cracking, and hydrogen migrating through such regions can find planes of weakness where it can exert very large pressures, which can lead to cracking. Cracks so induced can run in any direction.

Hydrogen will migrate quickly in hot metal, hence it will move rapidly from the weld pool to the adjacent heat affected zone of the parent metal, but thereafter, as this zone cools the fastest, its movement is retarded

The fastest cooling region is also the region that is likely to exhibit the hardest material. Therefore, hydrogen has a tendency to dwell in the region where it can do most damage, and any cracks which form may not be evident for many hours after welding.

To guard against such problems weld procedures should limit the hardness that may develop in the HAZ of the parent metal, or limit the amount of hydrogen that can get into the weld pool, or both.

Hardness in the heat affected zone increases with rate of cooling and with the amount of alloying in the parent material.

The amount of alloying in the parent material is expressed in terms of carbon equivalent value (CEV). A high CEV indicates that the parent material will develop considerable hardness if cooled quickly. A low CEV indicates low hardenability on rapid cooling.

The rate of cooling is directly proportional to the size of the heat sink provided by the parent material, (usually expressed as combined thickness), and is inversely proportional to the size of the weld pool.

The two main techniques of controlling the cooling rate are to increase the heat input into the weld pool (i.e. a bigger weld pool will cool more slowly than a smaller weld pool on the same joint), and to pre-heat the joint material before welding.

Obviously pre-heating the parent material will reduce the temperature differential to the weld pool and so reduce the flow of heat, but the

# Guidance Note

## No. 6.04

---

more significant point about pre-heating is that it reduces the thermal conductivity of the parent metal and this has a much greater retarding effect on the flow of heat from the weld pool to the parent plate, so reducing hardness in the heat affected zone.

The other benefit of retarding the cooling rate is that it allows a higher proportion of hydrogen to migrate to atmosphere so reducing the flow of hydrogen through the heat affected zone.

Potential sources of hydrogen in weld pools can be: the type of flux used (which may contain hydrogen); moisture absorbed into the flux; damp or rusty electrodes; moisture on the joint surfaces; oil or grease on joint surfaces or consumable wire; the atmosphere (if the effect of shielding gases around the arc is reduced by excessive air currents).

Even with the best of practice, hydrogen will be present to some extent in the weld pool. Different processes and consumables give rise to their own levels of diffusible hydrogen. Advice is given in BS EN 1011-2 on the diffusible hydrogen levels that can be safely assumed for the commonly used welding processes. Exceptional cases can be assessed by test.

By balancing the above factors, (heat input, combined thickness, pre-heat, electrode classification, and the CEV of the parent material), and by using the tables in BS EN 1011-2, a weld procedure to avoid hydrogen cracking can be developed.

The essence of the matter is simple. Higher levels of hydrogen can be tolerated as long as the HAZ hardness is low, or higher levels of hardness in the heat affected zone can be tolerated as long as the amount of diffusible hydrogen is low. But the two cannot be tolerated together, especially if the restraint applied to the joint and hence internal stress is high.

If the level of hydrogen is too high, relative to hardness and restraint considerations, it is possible for delayed hydrogen cracking to occur. This may occur on the weld surface, at the heat affected zone or sub-surface, within the weld/parent material interface.

Such cracking may not occur until a significant time after the weld has cooled. Until more

recent times, it was suggested that weld testing should be delayed for 48 hours to allow such cracks to occur. More discretion is now thought appropriate. BS EN 1011-2 (Ref 2) recognizes that the probability of hydrogen cracking in unrestrained thin material of low carbon equivalent is remote, while the probability in thick restrained sections of high carbon equivalent is much more significant.

Greater care should be taken with respect to delay in the case of the new higher strength steels (S420, S460), where experience is still limited and risks are higher. The discretion allowed in BS EN 1011 permits the delay time to be related to the particular joints, but caution should always be observed.

### **Solidification cracking**

From the above explanation it would appear that high levels of heat input in the weld pool together with high pre-heat would virtually eliminate the possibility of hydrogen cracking.

However, if the weld pool cools too slowly, a phenomenon called solidification cracking can occur. Another contributory factor is material composition; particularly susceptible materials are those with higher levels of impurities such as sulphur and phosphorus.

Slow cooling rates give rise to the growth of large metallic crystals, but in addition non metallic substances present in the weld pool (which have considerably lower freezing points) can stay fluid long enough to gather and cause intercrystalline weakness in the weld metal. This, combined with high levels of internal stress as the weld cools, can give rise to solidification cracking.

This is a problem which can arise with welding processes using high heat inputs; for bridge construction today the process with potentially the highest heat input is submerged arc. This is not to say that the process is undesirable or of low standard, indeed, used properly the submerged arc process can deposit very clean weld metal of very high integrity and was a major step forward when generally adopted by bridge fabricators in the early 70's. But just as with any inherently high powered machine, it needs to be properly controlled.

The solution to the problem is to restrict grain growth and render the non metallic inclusions harmless.

Grain growth can be contained by avoiding very high heat inputs or heat build up, together with the use of weld consumables with grain refining alloys. The most commonly used grain refining addition is nickel.

The problem of non-metallic inclusions is normally contained by the addition of manganese, which combines with the non-metallic materials to render them less harmful.

Solidification cracking is found in the centre of the weld bead and runs longitudinally in the weld. It is often also referred to as centreline cracking.

The geometry of the weld bead also has a bearing on the matter. A weld bead where the depth of penetration exceeds the width generates more internal stress on cooling than a weld bead where the reverse is the case. High internal stress will increase the probability of solidification cracking.

Solidification cracks will occur as soon as the weld cools; as soon as the weld is fully cooled, testing for this defect can proceed.

Annex E of BS EN 1011-2 (informative) provides further guidance in avoiding solidification cracking.

### **Comment**

To qualify as a welder in bridge construction, an operative is, regrettably, not required to have any knowledge or appreciation of the foregoing matters.

The more reputable fabricators take it upon themselves to give their welders some training and education in these matters.

As things stand, the quality of the welding supervisor in the factory or on site is the critical factor in ensuring that procedures are properly followed and in achieving the required standard.

### **References**

1. BS 5135: 1984, Specification for arc welding of carbon and carbon manganese steels. (Withdrawn)
2. BS EN 1011-2:2001 Welding. Recommendations for welding of metallic materials. Arc welding of ferritic steels





## Visual inspection after welding

No. 6.06

**Introduction**

This Guidance Note gives general information about the visual inspection of welds in structural steelwork for bridges.

**Scope of inspection**

As explained in GN 6.01, weld quality levels are specified in EN 1090-2 (Ref 1) in relation to 'execution class' and the MPS (Ref 2), which will normally be adopted by designers and specifiers, says that class EXC3 is appropriate for most bridge steelwork.

Visual examination is always required over the full length of all welds and it is advisable to carry this out as soon as the weld is completed to ensure there are no unacceptable surface imperfections. If surface imperfections are detected, EN 1090-2 states that the weld shall be surface tested by MT (or penetrant testing). The standard also defines minimum hold times after welding before supplementary NDT takes place, although it is prudent to conduct visual inspection as welding progresses to enable obvious problems to be addressed immediately.

EN 1090-2 also provides for the execution standard to identify specific joints for inspection together with the extent and method of testing. This is to accommodate more stringent examination when fatigue strength requirements are higher.

**Method of visual inspection**

EN 1090-2 states that visual inspection shall be conducted in accordance with EN 970 (Ref 3). The standard describes examination conditions and equipment necessary for effective visual inspection. The principal requirement being to ensure that all welds are present and in the correct location and are of the size specified on the drawings or welding procedure.

Size is specified according the convention "z" for leg length or "a" for throat thickness. UK practice to date mostly uses leg length to define weld size, however European practice uses throat thickness and the detailer needs to make it absolutely clear which convention is being used, to avoid misunderstanding.

EN 1090-2 also states that particular attention shall be paid to welded branch connections in

hollow sections and emphasizes the key areas for circular, square and rectangular sections where the shape and surface of welds needs careful attention.

**Acceptance criteria**

EN 1090-2 requires that, for EXC 3, joints the acceptance criteria for weld imperfections is Quality Level B to EN 5817 (Ref 4), except for "Incorrect toe" and "Micro lack of fusion", which are not to be taken into account. Additional requirements for weld geometry and profile need to be specified. The MPS (Ref.4) provides a vehicle for specifying alternative acceptance criteria relevant to geometry and profile.

The MPS also proposes that limits for throat thickness of fillet welds are too tight and not practical in a production environment. Unless excessive throat thickness is detrimental, the document recommends that Quality Level D (unlimited) shall apply.

For joints where an enhanced level of quality is required to meet design fatigue strength requirements, EN 1090-2 Table 17 gives additional requirements for class EXC4 as Quality Level B+. In addition the table also gives further supplementary requirements for bridge decks. These are more stringent acceptance standards for imperfection types over and above Quality Level B.

Generally the requirements for Quality Level B+ are not practically achievable in routine production. Indeed normal welding procedure and welder qualification tests are not assessed against acceptance criteria at this level. If a higher quality level is required, this should be specified for each relevant joint detail. Again the MPS can be used to specify more stringent acceptance criteria.

EN 1090-2 suggests that non-conforming welds be judged individually and evaluation should be based on the function of the component and the characteristics of the defect in terms of type, size and location in order to determine acceptability. Reference back to the design standard may be used to support the evaluation.

# Guidance Note

## No. 6.06

---

The imperfections that can be determined and assessed by visual examination are size and shape, cracks, cavities, removal of slag and spatter, stray arcing, surface breaking porosity, undercut, linear misalignment. For EXC 3 cracks and cavities are not permitted, slag and spatter shall be removed, stray arcing shall be lightly ground and the visual check supplemented by MPI of the affected area. Surface breaking porosity and undercut need to be carefully measured to assess acceptability.

Linear misalignment also needs measuring and assessing against the acceptance criteria. Out of tolerance misalignment may be acceptable subject to a design check and unless there is an aesthetic reason to correct the error it is better to leave an otherwise acceptable weld rather than risk an unsatisfactory repair.

The results from inspections should be recorded formally in a report giving details of the items examined, weld identification and acceptance criteria.

Figure 1 illustrates typical weld defects.

### **Repair**

Where a visual inspection identifies defects repair becomes necessary. In some cases this might involve a simple localized light grinding or dressing to correct the problem and it is not practical to report these.

For more substantial repairs which are reported through non-conformance and corrective action procedures, the repair is likely to involve gouging and welding. It is necessary to maintain control by implementing a repair procedure either of a generic nature or specifically developed to correct the problem. In either case, the completed repair area needs re-examination and reporting.

### **Inspection personnel**

All inspection to ensure the quality of the completed welding should be carried out by appropriately qualified and experienced personnel. EN 970 requires personnel be familiar with relevant standards, rules and specifications, be informed about the welding procedure used and have good vision which should be checked every twelve months.

In many cases, the services of an independent testing organization will be engaged, in addition to the inspection carried out by the fabricator. This independent organization will normally place an inspector at the works on a full- or part-time basis to monitor the inspection carried out by the fabricator as part of the production process, and also to carry out verification testing in parallel.

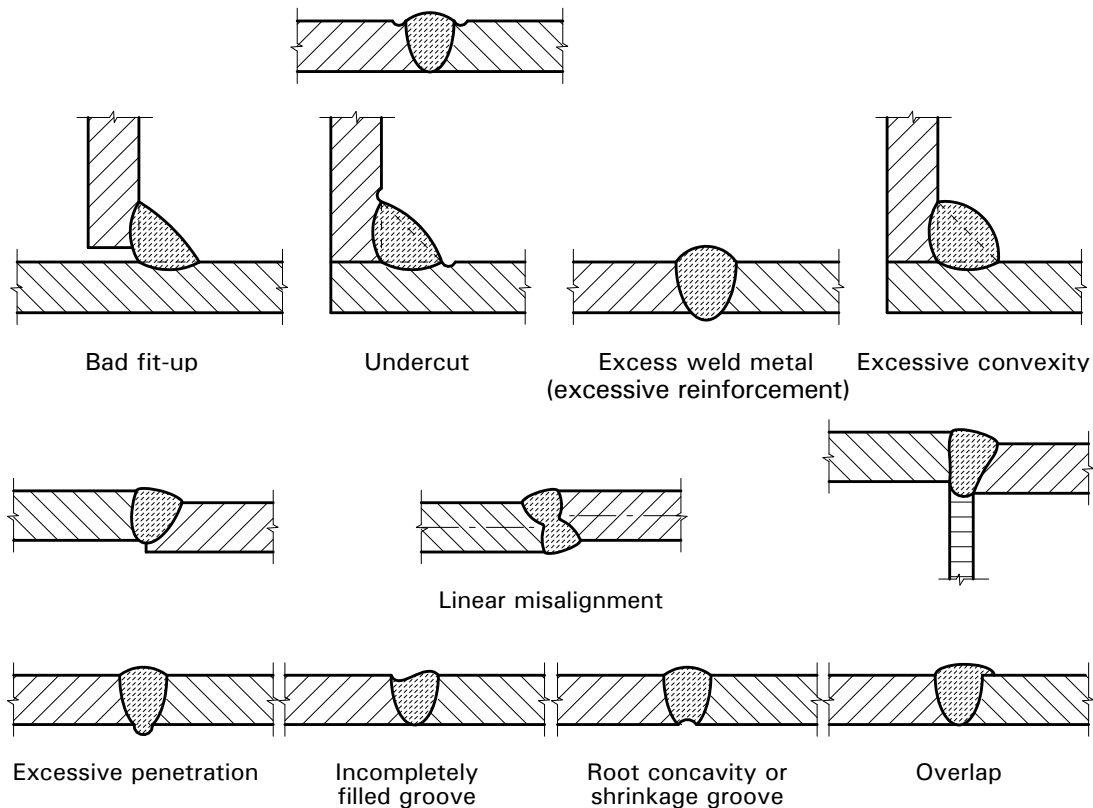

**Figure 1** *Typical weld defects or discontinuities*

#### References

1. EN 1090-2: 2008, Execution of steel structures and aluminium structures. Technical requirements for steel structures.
2. Steel Bridge Group: Model Project Specification for the execution of steelwork in bridges (P382), SCI, 2009.
3. EN 970: 1997, Non-destructive examination of fusion welds - Visual examination.
4. EN ISO 5817: 2007, Welding. Fusion-welded joints in steel, nickel, titanium and their alloys (beam welding excluded). Quality levels for imperfections.



### Scope

This Guidance Note focuses on the practical management and control necessary to achieve satisfactory performance of site welding operations.

### General

Technically, there is very little difference between undertaking bridge welding operations at site and in the workshop. The principal differences relate to issues of accessibility and the varying environmental conditions encountered, but with careful control, a range of welding techniques and practices can be as effective in the site environment as in the shop.

Inevitably, there are costs associated with managing any site operation, and economics will dictate whether welding is more cost effective than bolted joints. Handling and lifting activities and the provision of resources in terms of equipment and labour all contribute to the decision-making process. There are, of course, many other considerations and each project has to be assessed on individual merits. For a comprehensive review and a tabular comparison between welded and bolted splices, see GN 1.09.

### Characteristics of site welded joints

The location of site joints is normally determined at the design stage. Designers locate joints at points of contraflexure and/or where there may be intended changes of plate thickness. Ideally, the site joints should be in the thinnest materials, to minimize welding times and thus reduce costs.

Most site welds on bridgework are in-line butt welds in several positions including flat, vertical and overhead. Some fillet welds are required, for example to continue the web to flange joints or to introduce a stiffener or other member omitted in order to provide improved access for welding.

Shop trial assembly ensures reasonable fit up and alignment of joints but frequently site conditions cause variations in root gaps and misalignment of flanges and webs during construction. Some form of designed connection, either bolted brackets or welded landing cleats or a combination of both, is

necessary to connect the girder sections in the temporary condition prior to welding either at ground level or in the air. These temporary connections are normally removed after joint completion to restore the clean lines of the bridge. Temporary welded attachment areas need non-destructive testing to ensure that no unacceptable imperfections remain.

### Access, working platforms and shelters

Safety is always the prime consideration and all activities must be conducted in accordance with current statutory legislation.

Shelters are needed to provide protection for the operatives and to shield weld areas from wind and rain. Well-designed shelters provide an environment relatively free from draughts but running water is more difficult to protect against. To protect weld zones, more primitive methods of protection are needed, such as 'putty dams' to divert water flows away from the welding area.

Many or all of the joints require temporary access to be provided. Working platforms must be at a suitable height to enable welding to be undertaken in as much comfort as possible. Variable height platforms may be required on deep section girders to provide access to all parts of the joint.

It is necessary to protect the public, other trades and contractors from the risk of falling objects, grinding sparks and ultra-violet light from the welding arc. Fire risks need to be controlled and any hot metal spillage must be contained within the welding area in fire blankets or other non-flammable material. Molten metal dropping on timber boards can smoulder for many hours after work has ceased and can burst into flame when fanned by the wind.

Gas equipment needs to be regularly inspected to check for leaks and damage. Hoses carrying flammable gases for cutting and welding should be routed away from the immediate welding area and removed completely from enclosed areas, when not in use.

# Guidance Note

## No. 7.01

---

Inside box girder sections or other spaces where there is difficult access or poor ventilation, consideration should be given to the need for fume extraction and confined space working procedures.

### **Power supply**

Power is normally generated at site; it is rare to be able to pick up mains power to run equipment on bridge construction projects. The site needs and location dictate the economics of how this is done. One option is to have large primary generators powering several welding sources and perhaps other pieces of equipment, such as lights and power tools, via a distribution board. Alternatively, each welder might have his own mobile generator complete with welding and auxiliary power to run grinders and other electric hand tools. The latter system provides the flexibility to work on several remote fronts and does not stop everybody working in the event of a major breakdown on primary generation plant.

Electrical equipment is subject to safety regulations; installations should be checked regularly by qualified personnel. Clearly, equipment including personal protection equipment should be kept dry and in good condition to avoid the risk of electrical shock or burns. Damage to equipment and cables should be reported and regular inspections made to ensure earth connections are making good contact.

### **Refurbishment projects**

On refurbishment projects, site welding may include joining to or repair of existing structures and thorough site tests and investigations have to be undertaken to identify the material type and composition and to establish weldability. Clearly older materials are likely to present more welding complications than more modern materials of known history.

It should also be noted that the effects of direct high temperature flame or arc on some construction materials, such as lead-based paints and cadmium plating on bolts, produce highly toxic fumes that can create a severe hazard to health. Thorough investigation of the existing structure and risk as-

essment is essential before any cutting or welding operations are undertaken.

Contaminants such as oil, grease and paint have to be removed prior to welding operations taking place. The use of solvents and paint strippers necessitates appropriate risk assessment and safety precautions.

Where the nature of existing material is uncertain (and thus the determination of suitable welding procedures is difficult) it may be helpful to take small samples (from non-critical locations) using a Rotabroach tool. It is worth retaining any material that is removed as part of the refurbishment, so that test samples can be made.

### **Procedure control**

All site activity has to be controlled in accordance with written and approved method statements; welding operations are no exception. Risk assessments should address all potential site hazards including those specifically associated with welding operations. The method statement needs to include safe systems of work to overcome the hazards and to protect the workforce.

Welding procedures are an integral part of the method statement. Formulating welding procedure specifications should be under the control of personnel appropriately qualified, trained and experienced. Bridgework specifications typically require qualification testing of welding procedures in accordance with EN ISO 15614-1+A1(Ref.1). Procedures qualified in accordance with former national standards or specifications are not invalidated by the issue of this more recent standard, provided that technical requirements are equivalent.

Based upon these tests, detailed working procedures can be developed specifically for the project. Procedure development is influenced by the following factors:

#### *Processes:*

The two most important factors that affect welding costs are deposition rates and duty cycle. ('Duty cycle', in this context, is the ratio of actual welding (arcing) time to the total time, from setting-up before welding to

final checking and cleaning of the completed weldment. It is sometimes referred to as operator efficiency.) These factors are very much process-dependent and in turn influence the choice of site welding process.

Several welding processes are viable under site conditions and it is a matter of selecting the appropriate one for the application. The following comments are made in relation to the use of common welding processes (process numbers are as defined in EN ISO 4063 (Ref 2)).

- **Manual metal arc (MMA) welding.** (Process 111). This is the most widely used process for site welding because of its versatility and relatively simple equipment. It may well be the only practicable method where access is difficult or the joint is remote from the power source. Hydrogen controlled basic electrodes are required for welding of carbon manganese and low alloy steels and stringent storage controls are necessary to preserve their low hydrogen characteristics. Deposition rates and duty cycles are relatively low. The process produces its own gas shield around the arc from the flux coating. While this is a fairly robust process, it still needs shielding from direct draughts to avoid welding defects.
- **Metal active gas (MAG) welding** (Process 135) and **Tubular cored metal arc welding with active gas shield.** (Abbreviated to **FCAW** when using flux cored wire). (Process 136). Both of these processes can be effective at site and provide good deposition rates. However, the requirement for a gas shield necessitates good environmental protection otherwise draughts can blow away the gas and cause porosity and possible metallurgical changes. Solid or metal-cored wire electrodes (MAG) can be used successfully in the flat and horizontal positions, whilst flux-cored wires are better suited to positional welds.

The main disadvantage of these processes is the more complex equipment required. Rectifier or inverter type power sources and shielding gas bottles are normally situated at ground level. Wire feed units generally have to be positioned close to

the working area. Long interconnecting cables are required if the working area is remote. Duty cycles are higher than for MMA welding because there is no regular electrode changing and welders can sustain longer weld runs. Poor equipment management may adversely affect the duty cycle and regular maintenance is vital to prolong equipment usage.

- **Self-shielded tubular-cored arc welding (Innershield).** (Process 114). This process offers good productivity, with similar equipment to that for processes 135 and 136. It has the advantage that a separate gas shield is not required and welding can be undertaken in somewhat less effective shelters. Tight procedural control is required to ensure the mechanical properties of the weld.
- **Submerged arc welding with one electrode (SAW)** (Process 121) or **Submerged arc welding with tubular cored electrode** (Process 125). High deposition rates can be achieved with these processes but they are limited to flat plate butt or fillet welding and generally would only be economically viable in situations where long joints in thick plates or large fillets are required. The processes are normally mechanized on a tractor carriage unit and the equipment is therefore bulky and some form of guidance may be needed to follow the weld preparation. Other process variants include multiple wires or metallic powder additions but equipment becomes increasingly complex and therefore impractical for site use.

Most submerged arc welding fluxes are hygroscopic in nature and stringent handling procedures are necessary to condition the flux and to control weld metal hydrogen levels.

- **Drawn arc stud welding with ceramic ferrule.** (Process 783). For bridgeworks, welded shear stud connectors are required for composite construction or threaded studs are sometimes welded on for fixing formwork. These are normally shop welded to beams and girders, but occasionally, it becomes necessary to carry this out on site. Specialist subcontractors have mobile equipment capable of under-



# Guidance Note

## No. 7.01

---

taking this operation. Pre-production testing is required to ensure correct operation and performance of the equipment.

### *Welding position:*

The nature of bridge construction necessitates the welding of girder sections in position either before erection on the ground or after erection from access platforms. Typical I-section girder flanges are normally filled in the flat (PA) position from the top; back-gouging and welding to completion takes place in the more difficult overhead (PE) position. The web is normally welded from one side and back gouged and completed from the other side in the vertical (PF) position. Large cope holes are required in the top and bottom of the web to provide continuity in the transverse flange welds. Infill plates may require butt welding into the web to fill these holes upon joint completion and testing. Horizontal-vertical (PB) and horizontal-overhead (PD) fillet welds complete the joint. Working positions are defined in more detail in EN ISO 6947 (Ref.3)

Inclined webs of trapezoidal box girder sections and other architectural bridge designs may require intermediate positional welds and these need to be considered accordingly.

### *Joint set up and accuracy:*

Provided that a satisfactory trial assembly is undertaken at the steelwork contractor's works, there is every chance that the site joint set up will be accurate. However, it is inevitable that site conditions necessitate small adjustments to deal with plate misalignments. Experienced contractors anticipate this possibility and provide jacking and wedging equipment to effect these adjustments. Root gaps can be adjusted by trimming or weld metal build up, under procedure control to ensure that the welding conditions are within the range of dimensional tolerances allowed by the WPS.

Many contractors use ceramic backing to support the first run of weld deposited in the root area, to improve quality. These backings are supplied in a variety of shapes and sizes to fit on or in joints. Adhesive foil tape holds the ceramic backing in place. The advantage is that a higher current than normal for root

runs can be used to deposit the first run, thus minimizing the risk of fusion defects and ensuring a consistent penetration bead. The regularity of the penetration bead means that a minimum backgrind, if any, may be all that is necessary to dress the root prior to second side welding.

### *Sequence:*

Careful sequencing of the welds is necessary to reduce the risk of distortion and to minimize the building in of residual stress. With splices in I-section girders, the flanges are normally welded first, to allow the shrinkage forces to distribute themselves without any web plate restraint. Web gaps are sometimes deliberately set wide to allow shrinkage to occur, thus leaving the intended gap prior to commencing the web weld.

Large box girders may need a stepped welding sequence to distribute shrinkage forces in a balanced way to reduce the risk of distortion. It is very important to maintain dimensional control and to adjust the sequence if necessary to counteract distortion effects. It is more difficult to correct out-of-tolerance shape after welding than to take sensible precautions before and during the process.

### *Preheat:*

Preheating joint areas prior to welding and maintaining heat during welding is part of a strategy designed to avoid hydrogen (or cold) cracking of welds. It is an expensive operation and often difficult to control, particularly under site conditions. Temperature is dependent on factors including material thickness and composition, weld heat input and the hydrogen potential of the process used. EN 1011-2 (Ref 4) gives detailed guidance and methods for calculating preheats.

Applying preheat promotes the diffusion of hydrogen from the weld and heat affected zone and reduces thermal shock effects. In addition, it modifies the rate of cooling of the weldment to lessen the risk of forming crack susceptible microstructures in the heat affected zone.

Modern steel-making processes produce structural steels with good weldability and careful balancing of the factors affecting

hydrogen cracking can reduce the preheat requirement. Conditions requiring more stringent procedures are discussed in the Standard; of particular relevance to bridge-work are the comments on joint restraint. In any event, it is prudent to include in the procedure an instruction to warm the joint prior to welding to dispel any moisture present from, for example, damp weather or early morning condensation.

Methods of applying heat at site normally include using an oxygen-fuel gas lamp fitted with purpose made heating nozzles. Time needs to be allowed for heat to distribute through the thickness of the material. Temperature-indicating crayons or contact thermometers can effectively measure temperature. Larger lengths of joint in very thick materials may justify the cost of electrical resistance type heaters or portable induction heating equipment, which can be controlled using thermocouples to maintain accurate temperature.

It is important to keep a regular check on preheat temperature; the effects of cold weather and inherently large heat sinks can lower steel temperature rapidly.

Maintaining or even increasing the temperature for a period of at least 2 hours as a post heat-treatment assists the hydrogen diffusion process and can be included in the procedure. Control of post heating can only be done effectively using an electric heater system.

#### *Consumable storage:*

All welding consumable electrode products need to be stored in a clean, dry environment. Traditionally, hydrogen controlled electrodes are supplied in shrink-wrapped cardboard packaging. These need transferring to a drying oven before use to ensure that anticipated low hydrogen properties are achieved. Welders are issued with a quantity of electrodes in a heated quiver to maintain controlled storage at the work place.

Increasing use is being made of electrodes supplied in vacuum-sealed packaging, e.g. tins, foil wrap and plastic tubes. These are supplied with guaranteed low hydrogen

potential and eliminate the use of on-site ovens and quivers. However, it should be emphasized that hydrogen levels are preserved only when operators adhere strictly to the manufacturer recommendations for using these products.

EN 1011-2 emphasizes the point that the most effective assurance of avoiding hydrogen cracking is to reduce the hydrogen input to the weld metal from the welding electrodes. Stringent consumable storage and handling procedures provide this assurance.

#### **Welder approval**

Another important aspect of welding is to monitor the competence of individual welders or machine operators. The requirement for qualification or approval testing is prescribed in specifications and standards but the success of all welding projects relies heavily on the workforce having appropriate training.

Approval testing for bridgework in the UK is normally carried out in accordance with the requirements of EN 287-1 (Ref 5). The Standard prescribes tests to be conducted to approve welders for process, type of joint, position and material.

#### **Inspection and testing**

EN 1090-2 (Ref 6) is the Standard for the execution of steel structures and defines the inspection and testing requirements for welded joints. The execution class normally specified for bridgeworks is EXC3. Clause 12.4 of the Standard describes the welding inspection requirements. These may be supplemented by project specific requirements.

Non-destructive testing techniques typically include visual and magnetic particle inspection for surface examination, and ultrasonic testing for sub-surface examination. An alternative non-destructive testing technique is radiography but this method is rarely used on site because of safety and practicality issues. Guidance Note 6.06 describes visual inspection after welding and Guidance Notes 6.02 and 6.03 describe in further detail the surface and sub-surface non-destructive testing of welds.

# Guidance Note

## No. 7.01

---

Specifications normally state that personnel should be appropriately trained and qualified to undertake the work.

The Model Project Specification (Ref.7) describes the ring and bend testing required for any on-site welded shear studs. Of course, threaded studs should be load tested to confirm the weld integrity to avoid damaging the thread.

Important considerations at site again include maintaining safe access for inspection personnel until all testing is complete and satisfactory.

Destructive testing of production test plates may also be required where site butt welding is undertaken. The requirement is not included in EN 1090-2 and needs to be specified. Test specimens, such as, tensile tests, bend tests and Charpy impact tests need to be taken from extended run on/off plates attached to the joints. It is prudent that such plates are of sufficient size to permit the taking of extra samples in case the need for re-tests arises.

### References

1. EN ISO 15614-1: 2004 + A1:2008 Specification and qualification of welding procedures for metallic materials- Welding procedure test. Arc and gas welding of steels and arc welding of nickel and nickel alloys.
2. EN ISO 4063:2000 Welding and allied processes. Nomenclature of processes and reference numbers.
3. EN ISO 6947:1997 Welds. Working positions. Definitions of angles of slope and rotation.
4. EN 1011-2:2001 Welding. Recommendations for welding of metallic materials. Arc welding of ferritic steels.
5. EN 287-1:2004 Qualification test of welders- Fusion welding- Part 1: Steels.
6. EN 1090-2:2008 Execution of steel structures and aluminium structures. Technical requirements for steel structures
7. Steel Bridge Group: Model project specification for the execution of steelwork in bridges (P382), SCI, 2009.

### Scope

This Guidance Note provides some general information about the effects of temperature variation during bridge construction. Temperature variation causes the bridge to change length and, to some extent, to change shape (in profile and plan). This may require action to allow for the changes and for the differences between actuality and design assumptions; some general advice is given.

### Design

The actions due to temperature change in a bridge are given by EN 1991-1-5 in relation to a uniform initial temperature  $T_0$ . Design values of displacements at sliding bearings and at expansion joints are determined according to the variation from this initial temperature. The designer should, according to EN 1993-2, A.4.2.1, record this reference temperature on the drawings and give the required locations of the fixed and sliding bearings at this temperature. This information will allow the constructor to set the bearings appropriately during construction.

However, to set the bearings during construction, the constructor needs to know the effective uniform temperature of the bridge at the time. The temperature can be measured or can be estimated (as long as it is within 10°C) - for the latter case an allowance for uncertainty must be made in determining the design ranges (and the choice of estimation, rather than measurement, must have been anticipated in design).

The question thus arises as to what measures need to be taken during construction, at the key stages when dimensions are fixed, to establish the actual temperature of the bridge. When the temperature is not uniform, questions arise not only over length but over other dimensions (transverse, rotational, etc) when settings have to be fixed.

### Considerations

The principal considerations in establishing effective temperature are:

- Solar radiation. Of the effects causing changes in effective temperature, **the total solar radiation is the most powerful**

**and rapid. The effect is so strong that it does occur even through ordinary cloud cover.**

- The effects are quicker to be felt and quicker to dissipate in steel elements than in concrete. This effect is exaggerated if the steel is painted a dark colour.
- Clearly, the response of faces exposed to solar radiation is related to the orientation of that face to the incident energy. This means that low early or late sun or even low midday sun in the winter, will have a significant effect on the vertical faces and high summer or midday sun will have an effect on the horizontal surfaces of a structure.
- The effects of solar radiation are likely to be experienced disproportionately by different parts of the structure, leading to differential temperatures in the elements, with resulting distortion.
- The nature of the distortion is extremely difficult to predict. Hot sun shining on the deck of a deep girder bridge will cause the whole structure to expand and the girder to tend to hog between supports, but the effect will be unequal on a long main span compared to a short side span. This may actually cause the bearings to move in entirely the opposite direction to that expected in other conditions.
- Notwithstanding the above, open steelwork, such as a truss, responds very quickly (within an hour) to all changes in ambient temperature, whether exposed to sunlight or not. Closed box sections tend to have a significant lag in response (3 to 5 hours).

### Observations

A number of observations made over the years can be useful in determining whether there is likely to be a difficulty with a particular structure:

- On very long structures, there can be significantly different effects at different cross sections, especially if over different topography.
- Narrow decks are more susceptible to lateral distortion than wide decks.

# Guidance Note

## No. 7.02

---

- Deep girders behave more unpredictably than shallow girders.
- Box girders are more problematic than plate girders, and they can bend considerably in both the vertical and horizontal directions.
- Wide concrete decks which protect the steelwork from direct sunlight reduce the major effects.
- Structures with significant heat-sinks respond more slowly than plain steel skeletons. Concrete decks have a significant damping effect and the air inside box girders tends to slow and reduce the effects.
- Thin plated structures react more quickly to radiant heat and reach higher temperatures.
- A concrete deck surfaced with 'black-top' will react more than an unfinished concrete surface.
- An unsurfaced steel deck will respond more quickly to radiant heat and can reach higher temperatures than even a black-top surfaced concrete deck
- As the effects vary during the day, it is particularly important to be aware of them during the making of the site joints. Bolted joints could be locked up with unintended distortion built into the joint; incomplete welded joints could become over stressed and fail during the night following a hot, sunny day.
- All these effects are likely to be more troublesome with partly completed structures, i.e. during the erection process.
- Towers and piers react to diurnal variations in the position of the sun.

### **Assessing effective temperature for setting out purposes**

It can be difficult to determine the effective uniform temperature in practice because the two major influences (direct solar radiation and the subsequent dissipation of the stored thermal energy from the structure by radiation, conduction and convection) are transient and variable. However, this gives a clue as to how to deal with the problem, i.e. by reducing the effect of these influences to a minimum whenever one is faced with the

need to know the effective temperature of the bridge or parts thereof.

The most reliable information is acquired by avoiding the periods of day when solar radiation is present and also avoiding circumstances where the rate of change of temperature is significant.

Ideally, all setting out activities that are critically dependent on establishing effective temperature should be carried out at about three o'clock in the morning after three days of heavy cloud, with dry, still weather when there has been little or no significant change in the ambient temperature! In those circumstances the temperature of the (whole) structure will be as close to the ideal measured ambient air temperature as it will ever be. As the circumstances of this counsel of perfection are seldom achieved, and even less likely to be possible within the programme constraints, the advice is to avoid the contrary situation, i.e. do not attempt to set any critical components in bright sunlight, on a windy day, or after a cold night.

However, having made the above comments about how bridges respond and when reliable measurements can be made, it is pertinent to emphasise strongly that **it will not be necessary to undertake an accurate exercise to establish the effective temperature of most of the bridges that come within the range of spans covered by this series of Guidance Notes, i.e. up to about 50 m.**

Only for long structures, including multi-span viaducts, and decks of more complicated structures, such as lift bridges and swing bridges, will it be necessary to undertake special measures to establish the effective bridge temperature during the setting of bearings, expansion joints and pivoting/ locking devices.

### **Release of bearing transit cleats**

In most bridges (those less than 100 m long) the thermal expansion/contraction of the steelwork on erection (i.e. the difference between nominal and actual at the time of erection) is very small and can be taken up in the clearance between the lower fixings and

the concrete. Subsequent movements will also be small and will often not require the release of the transit cleats until the bearings are grouted. This relies on distortion of the transit cleats or on the bottom plate of the bearing sliding on the packs.

On longer bridges, however, the thermal expansion/contraction on erection is often larger than the clearance in the pockets, so the transit cleats have to be released and the top and bottom plates of the bearing offset from each other during erection in order to make the fixings. This has to be done carefully and be closely supervised to avoid disrupting any PTFE pads and seals in the bearing. Care also has to be taken to let the steelwork expand and contract in a controlled manner after erection and before grouting the bearings to avoid breaking the transit cleats or disrupting the packs under the bearing. It is good practice therefore on longer bridges to release the transit cleats once the steelwork has been landed.

### Recommendations

In all cases, by far the best advice is to observe what happens at supports as often as possible. A pattern of behaviour related to conditions preceding and during observations, is a much better guide than attempting to calculate behaviour in relation to a limited number of temperature measurements.

Correlating behaviour with predictions is much more reliable in stable and overcast conditions than in sunny or changing conditions, so make sure that there are sufficient observations under stable conditions.

For most composite bridges (up to around 100 m length), very few temperature measurements need to be made in order to establish a sufficiently accurate evaluation of the position of the steelwork at 'datum' temperature (and thus how the bearings should be set). Measurements need only be made of ambient shade air temperature in one or two locations.

For longer bridges, more accurate evaluation will probably be needed, but, fortunately, the construction period will probably be longer and this will offer more opportunity for observation. It may be helpful to monitor steel temperatures at the same time as ambient temperatures. In such cases temperatures at top and bottom flanges should be measured.

### References

#### TRRL reports:

LR 561, The calculation of the distribution of temperature in bridges, Emerson, M., 1973.

LR 696, Bridge temperatures estimated from the shade temperature, Emerson, M., 1976.

LR 702, Bridge temperatures calculated by a computer program, Emerson, M., 1976.

LR 744, Extreme values of bridge temperatures for design purposes, Emerson, M., 1976.

*(All published by Transport and Road Research Laboratory, Crowthorne.)*

EN 1991-1-5:2003 Eurocode 1. Actions on structures. General actions - thermal actions  
EN 1993-2:2006 Eurocode 3 Design of steel structures. Steel bridges.



## Verticality of webs at supports

No. 7.03

**Scope**

This Guidance Note explains the importance of web verticality at the supports of I-section beams, comments on the verticality limit in EN 1090-2 and discusses the verticality at the ends of skew decks.

**The importance of web verticality**

Bridge decks are usually arranged with a number of main beams (either beneath a compositely acting slab or at the edges of a half-through deck) that sit on bearings. The principal loading is vertical and the bearings are arranged to provide vertical reactions. Torsional restraint is provided at the ends of the beams, by means of bracing, by end trimmer beams, by U-frame action in half through bridges, or possibly by using linear rocker bearings.

If the web of a beam is not vertical over a support, the load transferred from the beam is inclined, because the shear in the web is in its plane. However, the reaction at the bearing is vertical and, in ordinary circumstances, there is no (external) horizontal reaction, other than through a small amount of friction on the bearing. Consequently, there is a horizontal resultant of these two forces at bottom flange level that must be balanced internally by some means; this is achieved by providing a couple at the top and bottom flanges, by reaction on the bracing (or other torsional restraint).

The magnitude of force that the bracing must sustain depends on the torsional restraint needed to stabilise the beam (according to the design rules) and the reactions needed to restrain the inclined web; the greater the inclination, the greater the required capacity of the bracing.

**Verticality criteria**

The only tolerance on verticality at bearings in EN1090-2 is in Table D.1.1 where a limit of  $D/200$  on squareness is given at support positions of beams without web stiffeners. For bridges, the MPS [Ref 2] specifies a limit on verticality of main girder webs at supports of  $\text{depth}/300$  or 3 mm, whichever is greater. It could be inferred that this criterion applies only to the girder as fabricated, not as erected, because Annex D of EN 1090-2

relates to *manufacturing tolerances*, but it is more logical to assume that it applies to the completed structure, because it should be compatible with the design rules for restraints in EN1993.

Note that the tolerance in the MPS is on web verticality, not on squareness of the flanges to the web. The squareness of the flanges to the web should not be inferred from the web verticality; the tolerance of  $\text{depth}/200$  given in Table D.1.1 could be applied, in addition to the MPS requirement.

It is recommended that project specifications be written to make it clear when the web verticality criterion is to be met. Unless the designer has made special allowance (see below), this should be achieved for the beams under permanent load conditions (i.e. all dead and superimposed dead loads).

**Web verticality at the ends of square decks**

When the bridge deck is square (i.e. zero skew angle), the main beams are perpendicular to the line of supports; in a composite bridge, bracing will usually be provided along the line of supports.

When the beams are loaded, they deflect, and at the supports they rotate only in the planes of the webs. There are no twisting deformations (save possibly for minor secondary effects). Consequently, the verticality that is achieved when the beams are erected and the bracing connected should substantially be maintained as the deck loads and superimposed loads are added

**Web verticality at the ends of skew decks**

However, the situation on skew decks is very different. If the beams are interconnected by bracing, as they usually are (or by a concrete diaphragm, as is also common), then the deflection under load will cause a rotation about an axis defined by the straight line drawn through the centres of the bearings at that support. This rotation can be illustrated vectorially, as shown in Figure 1.



# Guidance Note

## No. 7.03

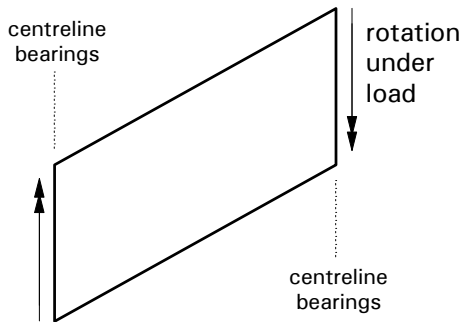

Plan on deck

**Figure 1** Vectorial representation of end rotations on a skew deck

The result is that there is a component of twist rotation applied to each beam as shown in Figure 2.

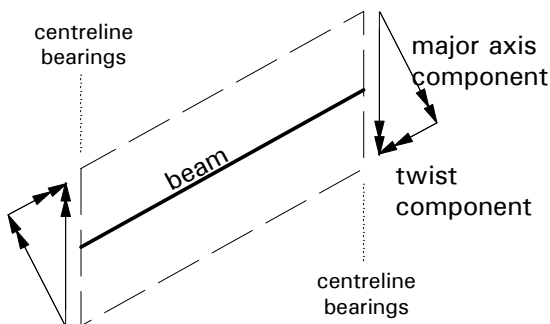

Plan on deck

**Figure 2** Vectorial components of the end rotations on a skew deck

The effect can also be illustrated by considering a plan view on one of the beam ends, as in Figure 3.

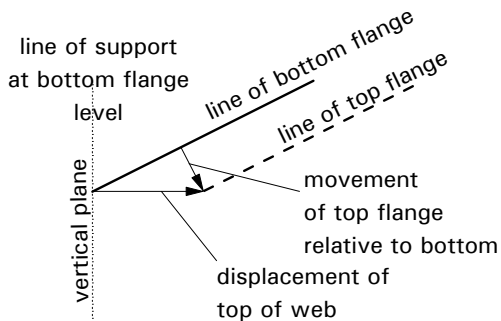

**Figure 3** Relative movement of flanges

A similar rotation (about the beam's longitudinal axis) occurs if there is bracing square to the beams, instead of along the line of the supports, as shown in Figure 4. Clearly, the deflection of one end of the bracing but not

the other, will cause rotation about the main beam axes.

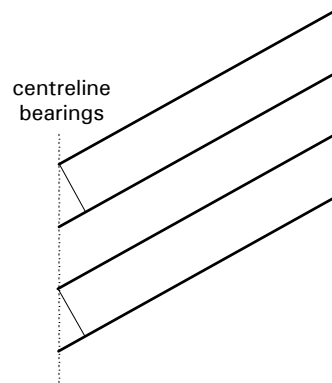

**Figure 4** Skew deck with bracing square to beams

At the ends of a single span, the twist can be significant if the skew is large. The end rotation of a typical bridge beam, due to dead and superimposed loads, can be of the order of 0.005 rad. If the girder is 1600 mm deep and at 45° skew, the movement of the top of the web relative to the bottom will be 5.6 mm. (Note that such a movement amounts to all the depth/300 tolerance, there is nothing left for any other deviations.)

### Rotations in continuous spans

In a single span, although the twist is in the same sense all across the span, the rotations at the two ends will be in opposite directions.

At the intermediate support positions of continuous beams there is little net rotation in the plane of the web (unless loads are applied before the beam is made continuous) and therefore no resultant twist. The greatest effects occur at the free ends of the bridge. (But note that if a skew bridge is built as a series of single spans, the twists at the two ends on an intermediate support would be in opposite directions and it may be difficult to achieve good alignment.)

### Checking web verticality

To ensure compliance with a specification of verticality at completion, a compliance check would need to be carried out after completion of the deck, surfacing and installation of all permanent furniture. However, this is too late to be of any practical value.

However, two alternative timings are possible: either during trial erection (if specified) or on completion of steelwork erection on-site. The latter is recommended. In either case, the designer should state clearly what is to be checked.

Checks carried out on completion of steelwork erection but, before deck construction, afford the opportunity to correct any out-of-tolerances before the steelwork becomes locked in position.

### Dealing with twist

In a composite bridge, the tendency to twist will occur predominantly under the wet concrete and formwork loading condition. If measures are to be taken to ensure verticality at completion, there are three alternatives for dealing with twist on skew decks:

- (i) Pre-set the beams during erection to offset the rotation which will tend to occur during concreting.
- (ii) Set the beams to be vertical at the end of steelwork erection and provide a form of temporary bracing at the supports that will prevent the rotation during concreting.
- (iii) Set the beams to be vertical at the end of steelwork erection and allow in the design for the calculated values of twists.

Option (i) is the recommended method. However it relies on calculation of the preset that is required. The effects at the beam ends can be evaluated from a grillage model; the model should include members to represent main beams, support diaphragms/trimmers and any other bracing between beams. The dead loads should be applied to a series of models to match the construction sequence.

Note, however, that if the bracing between a pair of beams, particularly diagonal bracing, is fabricated to the correct length in the completed condition, and that the connections are well fitted (i.e. bolt holes all in good alignment), the beams will automatically be preset so that the beam webs are vertical on completion., assuming that vertical deflections are as predicted.

Option (ii) can only be achieved where there is the opportunity to place temporary torsional restraint square to the ends of each beam, and this is rarely possible.

Option (iii) is used by designers who prefer to allow for the predicted twist during concreting as an additional tolerance. This implies that greater out-of-vertical (than depth/300) is acceptable (it is usually visually imperceptible). See further comment below.

### Predicting twist during concreting

Predicting final deflections exactly can be difficult for composite bridges, particularly skew composite bridges, owing to imponderables such as partial composite behaviour of slabs cast in stages, variations in concrete density and modulus, amount of cracking at internal supports, etc.

In most cases, twists that occur at supports during concreting tend to be less than predicted. Some designers therefore prefer to specify that the webs should be vertical at the bare steel stage (actually, assuming that they are out of vertical by depth/300 at that stage) and then to allow for the full predicted twist, adding it to the assumed depth/300. This would normally give a conservative value for the out of verticality on completion and the value would then be used to derive design values of restraint forces.

### Restraint forces due to non-vertical webs

EN1993-1-1 allows the consideration of imperfections such as lack of verticality either by modeling the actual geometry or by applying equivalent forces to the structure. Whilst the former approach will give the most accurate representation of the restraint forces, it will involve significant additional modelling effort because of the need to include second order effects and imperfections. An alternative is to use the method of restraint force calculation in PD 6695-2, 10.2.3.

### References

1. EN 1090-2 Execution of steel structures and aluminium structures. Technical requirements for steel structures.
2. Steel Bridge Group: Model project specification for the execution of steelwork in bridges (P382), SCI, 2009.



## Trial erection &amp; temporary erection

No. 7.04

**Scope**

This Guidance Note gives a general introduction to trial and temporary erection, the need for such activities and the use that they serve.

**General**

Temporary erection, more commonly known as trial erection, is a test of overall geometry and the standard of fit between the components forming that structure or part structure.

As with any other test, its extent should reflect the consequences of error.

The erection of a structure under or over a busy railway or motorway in a short closure requiring many weeks of advance notice will always justify a full trial erection for those spans so affected.

However, structures constructed on green field sites by experienced fabricators seldom warrant trial erection. Many major bridges in this country and abroad have been constructed successfully with little or no trial erection.

Problems can still arise on green field sites, but if the dimensions of major components are thoroughly checked in the factory before dispatch, then the solution to geometric problems and lack of fit on site can simply be the provision of a special splice plate or bracing which, with the aid of modern communications, can be provided to most locations in the UK within 48 hours.

The aggregate delay arising from problems resolved in the manner outlined above is generally much less than the time to carry out a full trial erection of the same structure. The physical solution to the problem is usually the same whether detected in a trial erection or on site.

Trial erection generally requires a large amount of space and on significant structures can take several weeks to carry out. Trial erection may appear to be a cheap operation and therefore prudent to specify, but it often represents a considerable loss of opportunity in terms of a quicker completion, the benefit of which might well have gone to the Client.

Think of trial erection as an insurance policy. The point to be assessed is what premium is paid for what cover.

**Specifying a trial erection**

Clause 6.10 of EN 1090-2 (Ref 1) requires the specifier to decide whether temporary erection is required, and if so, then to what extent. Clause 9.6.4 of EN 1090-2 gives some details of why trial erection might be considered, while clause 12.7.1 gives an opportunity to specify any particular requirements for inspection of the trial erection.

Specification of trial erection, where considered necessary, should be made in the project specification for steel bridge works. The Model Project Specification (Ref 2) gives guidance on how this document may be arranged, with trial erection covered specifically in 6.10.

The decision of whether to specify a trial erection should be based on a properly considered risk assessment of the consequences of lack of fit, or of incorrect geometry.

The specifier will act in the Client's best interests if he considers the matter from the standpoint of why should there be a trial erection rather than the reverse position.

If a trial erection is required, its extent should be clearly specified.

**Mode of trial erection**

The fabricated steelwork components for a bridge structure are usually dimensioned for the unstressed condition, i.e. where all self-weight and superimposed loads have been removed (see GN 4.03).

The fit-up of components should be checked in a similar condition, i.e. they should be supported such that there are no significant self-weight deflections in the components being assembled. An example of a support system for a three-span bridge is shown in Figure 1 (cambered profile exaggerated for effect).

Specification clauses that require trial erections to be supported only at the bearing positions achieve little in terms of proving structural fit-up, especially in the case of continuous bridges. There may well be some unusual

# Guidance Note

## No. 7.04

circumstances where such a requirement is desirable, but in the general case it would only serve to add time and cost without benefit and should therefore be avoided.

Similarly, clauses requiring the temporary erection to reflect the construction sequence achieve little in terms of a normal project and should not be specified.

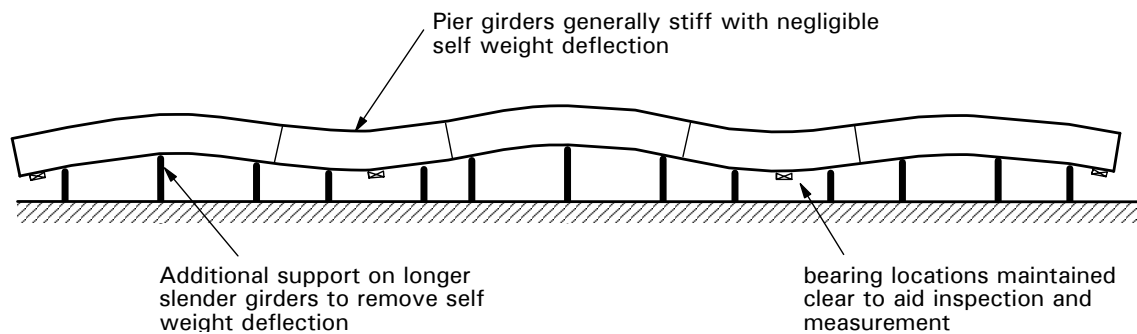

**Figure 1** Typical support arrangement for trial erection of a continuous three-span bridge

Full trial erections can take up a large amount of space, often more space than is required for construction on site. If space is a constraint to the fabricator then incremental trial erection is usually quite satisfactory.

For structures with significant longitudinal fall, it is often of benefit to rotate levels to avoid excessively high supports in trial erection. It should be remembered, however, that if the structure has plan curvature then it should be anticipated that such rotations will lead to webs being out of vertical in a number of locations. The amount and direction are predictable.

In a similar manner it may well be the case that heavily skewed bridges designed with composite concrete decks may require the girder ends to be out of vertical on erection so that the subsequent concreting operation tends to bring the girders back to vertical. (See GN 1.02)

It is desirable that only a proportion (typically about 25%) of the bolts are used in trial erection. The inspector of the trial erection will then be better able to assess the general alignment of the holes in any group. A bolt in every hole could be concealing evidence that significant force has been used to bring the components together. Some force will always be required, but if bolt holes show distortion through excessive drifting, or local distortion of members is evident, undue force has been used.

Temporary bolts, generally referred to as service bolts, should be used in trial erection. Service bolts may be of any grade, but must be of the same shank diameter as the permanent bolts and of sufficient length. The permanent bolts should not be used. It is suggested that about 25% of the holes should be filled with service bolts for web and flange splices, and about 50% of the holes should be filled in bracing connections and the like.

Some fabricators use the trial erection to match mark groups of holes critical to overall structural geometry or to back mark preparations for site welded joints. Generally there should be no need to reassemble the structure after hole groups so marked are drilled or welded joint preparations cut.

It is often prudent to include the bearings in the trial erection. This is the major interface between the superstructure and the substructure and experience shows that this is where things go wrong most often. Inspection of the trial erection is made easier if bearings are included.

### Inspection of trial erection

Persons required to carry out the inspection of a trial erection should carefully plan how and what they intend to inspect, taking access into account.

They should familiarise themselves with the appropriate tolerances in the contract before they start, and they should also agree the expected dimensions for the trial erection with the fabricator several days before the inspection is due.

The following check list has been compiled to assist inspection.

First, check the overall geometry:

- (1) Span dimensions, including diagonals (remember to differentiate between slope and plan dimensions).
- (2) Girder spacings at all supports (again remember to differentiate between slope and plan dimensions).
- (3) Skew angles/offsets.
- (4) Relative levels of girders at supports. Generally the most practical way to do this is to survey at top flange level. Remember that where there is longitudinal fall in the structure it is important to locate these points accurately. Remember to allow also for any flange thickness changes which may alter levels
- (5) Relative levels at girder joints, or at midspan for single span structures.
- (6) Verticality of girder webs at supports,

Secondly, check fit-up:

- (1 ) The alignments of all splices and butt joints (see clause 8.1 of EN 1090-2).

(2) The proper bedding of splice plates in preloaded bolted joints (see GN 2.06).

(3) The alignment of bolt holes, so that bolts can be installed without undue force.

(4) The alignment of bracing members with their respective stiffener connections.

(5) Fixing of the correct bearing plates to the correct girders, (i.e. differentiate between those for fixed bearings, guided bearings and free bearings).

(6) Orientation of each bearing plate, in terms of any taper.

(7) Orientation of fixing hole groups in each taper plate, and diameter of holes.

Note any missing items or incomplete fabrication.

As a guide, a well organised two man team can carry out the above inspection regime on a bridge eight girders wide and two spans long in a day.

### References

1. EN 1090-2:2008, Execution of steel structures and aluminium structures. Part 2: Technical requirements for the execution of steel structures.
2. Steel Bridge Group: Model Project Specification for the Execution of Steelwork in Bridge Structures (P382). SCI, 2009.



## Installation of preloaded bolts

No. 7.05

**Scope**

This guidance note relates to the use of preloaded System HR bolts to EN 14399-3 (Ref 1) and System HRC bolts to EN 14399-10 (Ref 2) in bridge steelwork. The principal uses are in making main girder connections (web-to-web and flange-to-flange) but they are also used in connecting bracing members, to main girders and to each other. This Note refers to use in such details. Special applications should be considered in their own context.

Comments on accommodating tolerances in hole sizes and positions is given in GN 5.08.

**Source References**

EN 1993-1-8 clause 2.1 (Ref 3) states that the design methods for joints assume that the standard of construction is as specified in EN 1090-2 (Ref 4). Particular clauses in EN 1090-2 that relate to preloaded bolted connections include:

- 5.6.4 - specifies that structural bolting assemblies for preloading shall conform to the appropriate part of EN 14399;
- 5.6.6 – permits the use of the ASTM standard for weather resisting assemblies;
- 6.6 - covers the requirements for holing;
- 8.1 - covers thickness of packing plates;
- 8.2.2 - defines the minimum length of protrusion and the number of clear threads required under the nut;
- 8.2.4 - covers the type and number of washers required depending on the joint configuration and the bolt grade;
- 8.4 - covers the preparation of contact surfaces;
- 8.5 - describes the various tightening methods.

**General**

Connections made with preloaded bolts are designed on the basis of a minimum preloading force in each bolt, no matter how many bolts in the connection, nor their distribution.

Hence the key to effective jointing is to ensure that minimum preload is achieved.

The actual preload in any bolt is governed by three things:

- the tensile strength of the material; the “property class” in accordance with EN 14399
- the thread diameter of the bolt; as specified by EN 14399
- the extent to which the bolt is strained (extended) during the installation and tightening process; which is required to be in accordance with EN 1090-2.

By means of careful manufacture and installation the designed minimum preload is easily achieved in a simple unrestrained lap joint between two plates. Problems begin to arise in joints which are restrained, when the contact surfaces are not flat and/or not properly aligned.

Unfortunately, the manufacture of individual elements to the tolerances specified in the various clauses of EN 1090-2 does not guarantee that the connection will fit sufficiently well to permit the connection to perform as intended. Unfavourable combinations of the maximum and minimum tolerances in any particular assembly and/or in any adjacent assemblies, can result in misfits which will affect the performance of the connection. CIRIA Report 87 (Ref 5) deals with the common instances of these and gives guidance on the likely effects. A commentary on that document is given at the end of this Note.

GN 2.06 suggests connection details that are least sensitive to these unfavourable combinations of permissible tolerances. It also gives guidance with regard to the misfits of those joints/details that are not so tolerant. The guidance in the present Note assumes that the joint details and fit are reasonably good.

**Assembly**

The following points are important:

- Contact surfaces should be flat and free of any buckles, dents or burrs around the holes
- Contact surface should be clean and free of any oil, grease, paint or other material that could act as a lubricant. Moisture on a face, in the form of clean water, rain or dew should not be a problem unless it washes in dirt or is present for so long that



# Guidance Note

## No. 7.05

---

serious rusting occurs. Light rusting is not detrimental to the performance of the joint.

- Bolts should be able to be inserted without damaging them or the holes. This does not mean that all holes should be perfectly aligned, as bolts can be worked into quite big joints one at a time by moving the joints faces slightly relative to one another (see GN 5.08).
- The connection should be drawn together by using a pattern of bolts, not a single one tightened to a very high load. 'Service' bolts may be used, but it is perfectly acceptable to use the permanent bolts so long as they are not damaged or stretched. *(Service bolts are temporary bolts used to hold elements together and in the correct orientation to each other during assembly. In normal circumstances they are non-preloaded bolts in clearance holes, of the same diameter as the permanent preloaded bolts. They have to be replaced by the new permanent bolts in the final joint assembly. As they are seldom tightened to more than 'spanner tight', they can be reused time and time again.)*
- Preloaded bolts should only be used for pulling joints together so long as they can be inserted without any damage to the threads, and so long as only hand spanners or small (low-torque) impact wrenches are used to draw the plies together. This practice is not recommended when the torque method or the combined method of tightening is to be employed because the slackening, removal and re-use will change the thread friction from that for which the equipment was calibrated.
- After insertion and initial tightening, the nut should be fully engaged on the bolt threads. This is to avoid possible damage to the threads during final tightening. The ideal situation is to have one or two threads protruding through the nut after final tightening, although EN 1090-2 clause 8.2.2 only requires a protrusion of one thread.
- If it is suspected that a preloaded connection has relaxed for some reason and the torque method of tightening has been used (after correct assembly), such bolts may be retightened to the correct torque. If relaxa-

tion is suspected and the part-turn method has been used, the bolts should be replaced and tightened one by one.

- Preloaded bolts which have been fully or partly tightened should not be re-used in the Permanent Works, because they have already been stretched. They can be useful as service bolts, but care must be exercised to ensure that they are not accidentally retained in the completed assembly.
- Protective treatment - some additional guidance on the treatment of connections made with preloaded bolts is given at the end of this Note.

### Methods of tightening in EN 1090-2

EN 1090-2 describes four methods of tightening system HR preloaded bolts:

- Torque method

The torque method is a three-stage operation (snug-fit, initial torque, final torque) using a calibrated torque wrench. The main shortcoming of this method is that the variation in bolt preload, for the same batch of bolts and nuts, can be as much as  $\pm 30\%$  and even more if the bolts are coated. This variation is caused mainly by the variability of the thread condition, surface conditions under the nut, lubrication, and other factors that cause energy dissipation without inducing tension in the bolts. The result is an erratic torque-tension relationship and an unreliable preload.

EN 1090-2 attempts to minimise variability by requiring the use of 'K2 class' bolts for the torque method. K2 class bolts require greater performance measurement during manufacture (see EN 14399-2), with additional information about the torque v tension relationship required on the product certificate. For these 'higher class' bolts, the requirements for wrench calibration are then only that the equipment be checked "for accuracy at least weekly, and in the case of pneumatic wrenches, every time the hose is changed". From experience, it is considered by UK steelwork contractors that much more frequent calibration is required.

Additionally, there is a supply problem in the UK in that the main supplier of bolts for preloading (Cooper and Turner) will only

supply KO class bolts - this class does **not** have a designated bolt force / rotation relationship and, according to EN 1090-2, is not suitable for any of the described methods, other than the direct tension indicator method.

- Combined method

This is a method that is new to the UK. It is a combination of the torque and part-turn methods, so it has all of the disadvantages associated with torque control. It requires three tightening operations (snug-tight, preliminary tightening and final tightening).

- HRC method

The HRC bolt has a spline at the end of the threaded end of the bolt that shears off at a predetermined torque. It is not necessary to calibrate the wrench in this case because the strength of the break-neck determines the maximum torque. However the actual preload induced depends on the torque/preload relationship and this is still related to the thread friction. The variability of the friction is controlled by supplying the bolts in drums to protect them from weather and contamination, but the lubrication can be affected by rain once the bolts are in place and ready to be tightened. They are not available in weathering steel in the small quantities required for most bridge projects (and a significant proportion of highway bridges now use weathering steel).

- Direct tension indicator method.

Direct tension indicators (Ref 8) are washers that have compressible nibs that deform to indicate when the minimum preload has been achieved. They are available in weathering steel but their use in the UK has been prohibited by the Highways Agency in the Specification for Highway Works because crevices are created that would become corrosion traps. When used on painted bridges, the gaps in the washers have to be sealed by hand before painting.

### Preferred method of tightening

The fabricators of a large proportion of UK steel bridges prefer the part-turn method, which requires two tightening operations (snug-tight by the application of a defined bedding torque, followed by a part turn). Although this method is not specifically defined

in EN 1090-2, it can be used on condition that it is shown by calibration to provide the minimum preload required. Details of the method, verified by calibration of M24 and M30 System HR Class 8.8 bolts, are given in clause 8.505 of the MPS (Ref 9).

The main advantage of part-turn tightening is that it is a strain control method and is therefore almost totally independent of the friction and torque characteristics of the nut and bolt assembly. The part-turn method induces a specific strain (related to the part turn and thread pitch) that is well in excess of the elastic limit and which takes the bolt into a region where the load-elongation curve is relatively flat, so the variations in (the relatively modest) bolt load applied during bedding result in only minor variations in the preload of the installed bolt.

This consistency provides the following benefits to the steelwork contractor and the client:

- Predictability: Preload always exceeds the minimum specified;
- Reliability: Simple to control and supervise on site;
- Economy: No calibration on site and less risk of re-work, so lower costs;
- Versatility: Suitable for both non-alloy steel and weathering steel bridges.

### Initial fit-up

All tightening methods need the components to be brought together to a snug-tight condition before commencement of preloading. However, there are occasions when the initial tightening does not achieve this, for example when thick splice plates and rippled flanges coincide, or where geometric fit-up is imperfect. Installers and inspectors should therefore be vigilant that all the plies are in contact before the main preloading process starts. Plate rippling is usually greatest at the ends, due to the mechanics of the rolling process. In this case it can be difficult to bed splice plates in excess of 25 mm thick when using bolts up to and including 24 mm diameter. To overcome the problem, laminated splice covers should be used (two or three thinner plates, which together provide the required thickness).

# Guidance Note

## No. 7.05

---

### Inspection

A significant part of the cost of using preloaded bolts is related to the inspection. This is the key to the effective use of preloaded bolts so should be carried out strictly in accordance with the requirements of EN 1090-2.

Preloaded bolting should be considered as a connection method that requires formal procedures just as much as welding does.

While it is not specified in EN 1090-2, it is suggested that:

- only personnel qualified by experience and training are used;
- only tested and calibrated equipment is used;
- written procedures are used to control the work;
- inspection is performed and records are kept to a formal procedure.

### Bolt supply

The source of bolts should be an accredited supplier, as low-cost versions that do not comply with EN 14399 are marketed. Beware of 'certificates of conformity', because they are not reliable from these cheap sources.

### Protective treatment and protection of contact surfaces

It is common practice to specify unsealed aluminium metal spray on contact surfaces in preloaded bolted connections (faying surfaces). The purpose of this is to avoid heavy rusting of an otherwise untreated surface, which might lead to a reduction in the slip factor, or staining of adjacent treated surfaces. It also avoids the need to seal the joint at an early stage. A slight browning of an unsealed aluminium coated surface exposed to moisture is to be expected and is not a matter for concern.

Clause 8.401 of the MPS calls for protection of contact surfaces where a particular treatment

is specified. The usual method is with adhesive masking tape, of which there are a number of varieties on the market. Experience has shown that those tapes which give the best level of protection tend to leave adhesive deposits on the friction surface when peeled off, especially if they have been left in sunlight for extended periods, or have been over-coated with paints with high solvent levels. Such deposits can be cleaned from the friction surface with solvents and scrapers or wire brushes or the like, but such activities can reduce the slip factor. The tapes which do not leave deposits on the friction surface tend to be only effective for a limited period in the open, usually two to three months.

### References

1. EN 14399-3, High strength structural bolting assemblies for preloading - Part 3: System HR - Hexagon bolt and nut assemblies.
2. EN 14399-10, High-strength structural bolting assemblies for preloading - Part 10: System HRC - Bolt and nut assemblies with calibrated preload.
3. EN 1993-1-8, Design of Steel Structures – Part 1-8: Design of Joints.
4. EN 1090-2, Execution of steel and aluminium structures – Part 2: Technical Requirements for Steel Structures.
5. Report 87, Lack of Fit in Steel Structures, CIRIA, 1981.
6. BS 4604-1, Specification for the use of HSFG bolts in structural steelwork – Part 1: General Grade.
7. Specification for Highway Works, Series 1800, Structural steelwork, 2005.
8. EN 14399-9, High-strength structural bolting assemblies for preloading. System HR or HV - Direct tension indicators for bolt and nut assemblies.
9. Steel Bridge Group: Model Project Specification for the Execution of Steelwork in Bridge Structures (P382), SCI, 2009.

CIRIA report 87, although an old publication, is still recommended reading for designers, contract managers and site staff. The following bullets highlight some of the key conclusions in the report. Reference to HSFC bolts have been changed to refer to preloaded bolts, which is the terminology now used.

### Comments on CIRIA Report 87 - LACK OF FIT IN STEEL STRUCTURES

- The report reinforces a long-held view that preloaded bolts give an excellent rigid and fatigue/crevice-free joint, but all attempts to obtain precise bolt tensions are a total waste of time!
- Ultimate strength of preloaded joints is not affected by lack of fit, or the amount of bolt pretension, for joints in shear (see 2.5.2 & 2.8.2) or tension (2.8).
- The annulus which is effectively clamped extends over an area equivalent to twice the nominal bolt diameter. (2.5.1)
- For end plate connections, bowing is not detrimental to tensile capacity, provided it is convex on outer face (i.e. gaps between end plates at outer edges, not at centre). However, top and bottoms of end plates to be in contact (2.6) especially in region of compression flange (2.8.1). Contact elsewhere unimportant. Lack of fit around bolts of up to 1 mm may not affect performance. (Appendix 2).
- In fatigue situations (i.e. where reversal of load occurs) good fit-up around the bolts is important (2.9). (Applies particularly to bridge girders spliced near the point of contraflexure.)
- Shimmed end plate joints are satisfactory (2.10).
- For oversize and slotted holes a reduction in capacity is evident (2.11) but it is implied that inner ply oversize/slots are not detrimental.
- For bolts in shear, reaming of misaligned holes "could be harmful" (3.2.2)
- Varied misalignment in a group reduces slip under load causing more gradual (and presumably beneficial) deformation (3.3).
- Hole misalignment does not affect bolt tensile capacity. (3.7).
- Distorted bolt ends, up to 3°, are acceptable. (3.8.1).
- Full nut engagement may not be necessary for bolts in shear (3.8.2) - this would apply to ULS capacity after slip; full engagement is required for preloaded bolts, to ensure friction capacity.
- Corrosion in crevices is highest with a gap of 0.75 mm. (7.3.1).



### Scope

This guidance note relates to the transport of large items of steelwork, machinery and equipment, both on public roads and at the construction site.

### Vehicles

All delivery vehicles, large mobile crane bodies and support vehicles are principally road-going vehicles and conform to the various statutory HGV categories.

They all have attachments which allow them to be towed but these are not designed to be used where the vehicle is loaded and on bad ground.

Most large mobile cranes (i.e. 300 t and above) are attended by low loaders which are usually used to transport counterweight. Owing to their low ground clearance and small diameter wheels, these vehicles are the least tolerant to bad ground.

### Abnormal loads and movement orders

Vehicles with rigid vehicle length less than 18.75 m, width less than 3.0 m, gross weight less than 44 tonnes, with no axle over 11.5 tonnes, and overall height less than 4.95 m can travel anywhere at any time, except where the route includes an under-bridge with weight restriction or an over-bridge with height restriction. In the case of transportation of bridge girders, rigid vehicle length is usually the girder length.

Transportation requirements for main girders on bridge projects often fall outside the above limits and there are then various restrictions on movement.

Certain vehicles that exceed the above 'ordinary' limits are covered by a section of the Road Traffic Act 1988, entitled "Road Vehicles, (Authorisation of Special Types) (General) Order". The latest Order is SI 2003 No.1998. The letters STGO, which are displayed on the tractor unit of most abnormal loads, are an abbreviation for this section of the Act. The regulations apply to "Abnormal Indivisible Loads". The word indivisible is important; if the load could be readily split into two or more loads each complying with the normal regulations, as set out in the first paragraph above,

then approval is likely to be denied. If, for example, the girder being transported were formed of two part-girders bolted together, it might be regarded as divisible; if it were formed of two parts that were welded together it would be considered indivisible. In any event, it is a matter for the fabricator and his haulier to consider and resolve.

Table 1 sets out the limits for the three STGO categories. Loads within these categories can move subject to notice to the authorities.

It is necessary to give notice to each police area on the planned route when the load is longer than 18.75 m or wider than 3.0 m, or the gross weight is in excess of 80 t.

It is also necessary to give notice to bridge owners (Highway Authorities, Network Rail, British Waterways, etc.) along the route if the gross weight exceeds 44 tonnes. (The notice given indemnifies the owner against damage potentially caused by the load.) They do not have to be notified if only the dimensions (length or width) are abnormal.

Recently, the operation and maintenance of some sections of roads have been privatised. In such cases, the responsibility of receiving and acting upon notification from hauliers falls to the private company responsible for the road.

Special provisions exist for Greater London and for holiday regions in high season, which may restrict movements at peak periods and at weekends.

If the vehicle and load to be moved fall outside the STGO categories it is still possible to move, but approval must be gained from the Highways Agency (or the Scottish Executive or Welsh Assembly Government) in the form of a VR1 Permit or a Special Order. All details of the load must then be notified to the Highways Agency, together with precise dispatch and delivery points. At least three months should be allowed between the first application for such a permit or order and the anticipated date of the actual movement.

A Special Order details the approved route and must be followed exactly.

# Guidance Note

## No. 7.06

Special Orders are usually valid for 6 months. The specified notice must be given to each police region for the actual movement. Notice

must also be given to the relevant bridge owners, together with a specific indemnity to each.

**Table 1** *Limits of weight and size for STGO vehicles*

Vehicle Type (STGO)	Max Laden Weight	Max Axle Weight	Max Vehicle Length	Max Vehicle Width	Notice to Police
Category 1	50 tonnes	11.5 tonnes	30 m	5 m (6.1 with VR1)	2 days
Category 2	80 tonnes	12.5 tonnes	30 m	5 m (6.1 with VR1)	2 days
Category 3	150 tonnes	16.5 tonnes	30 m	5 m (6.1 with VR1)	5 days

The notice period given above is normal working days (i.e. excluding weekends and public holidays). The period excludes the day of movement and the day of notification. (a VR1 permit form is obtainable from the Highways Agency)

### *Length of load*

A vehicle of rigid vehicle length over 18.75 m but less than 30.0 m (and within the limits of width, weight and axle load mentioned above) requires that notice be given to police.

Any vehicle with rigid vehicle length over 30 m requires a Special Order, as well as the notices to police, etc.

Loads that create a rigid vehicle length between 40 m and 50 m are fairly common, and loads in excess of 75 m have been approved for relatively short movements. No maximum length is given by statute for loads subject to Special Order. However, it should not be taken for granted that an Order can be obtained for any long load, as it is a matter for agreement in each case.

### *Width of load*

Loads over 3.0 m and up to 5.0 m wide require notice to be given to police. Notice to local authorities and other bridge owners would only be required if other limits (on gross weight or axle load) are also exceeded.

Loads between 5.0 m and 6.1 m wide require a VR1 permit, and those over 6.1 m a Special Order. As with length, there is no statutory limit to width, each case being treated on its merits.

Widths up to 5.2 m receive regular approval for movements around the UK. Wider loads often

receive permission to move on individual assessment. In those cases the road distance is not likely to be great.

### *Load height*

A height clearance of 16'3" (4.95 m) is available on all motorways. Any load height above 16'6" must be notified to wire authorities (telephone, electricity, etc.).

Many railway and other bridges over roads have less clearance than 4.95 m. Great care should be exercised to ensure that sufficient height clearance is available under any bridges along the route. Police approval, or approval from any bridge owner is no guarantee that height clearance is available.

It is the driver's responsibility to obey height restriction signs, although highway authorities will give help and guidance if requested.

### **Site roads**

Although steelwork fabricators generally require Main Contractors to be responsible for providing suitable access roads, there is a general obligation for the fabricator to take reasonable steps to satisfy himself that what has been provided is safe and satisfactory. The site roads and any areas on which the vehicles are to stand or travel must be properly prepared to carry the wheel loads and the layout must be adequate for manoeuvring.

The availability of towing equipment (to tow transport vehicles that might become stuck) should not be accepted in lieu of adequate

ground preparation. If a vehicle should for any reason lose traction then it is for the driver to decide if towing is appropriate. On no account should pushing be permitted.

Gradients on site roads require surface conditions such that delivery and crane support vehicles are able to generate sufficient traction to propel themselves. If in doubt, consult the haulage company/crane supplier.

The transitions at the top and bottoms of gradient are particularly important.

Ground clearance is important to low loaders on convex curves.

However, the most critical vehicle in this respect is the multi-axle crane body, where certain axles steer and certain axles drive. Therefore, to maintain proper control of this vehicle, all axles must stay on the ground; it is unacceptable to rock on a convex curve or to bridge a concave curve.

Note that heavy dump trucks, tippers etc., run on large diameter and wide tyres inflated to low pressures to enhance their rough terrain

capability. They are therefore unrepresentative of road going vehicles.

The site access road should be suitable in all weather conditions likely to be encountered. Therefore beware of assessments made in prolonged dry weather or prolonged freezing conditions.

Temporary structures on site must be checked for each abnormal load. In carrying out such checks, care should be exercised if the axle loads stated on the Special Order are used. These can give a significant over-estimate of vehicle gross weight, because hauliers often claim maximum allowable load on each axle to give latitude in the positioning of the load on the vehicle.

### **Highways Agency procedures, ESDAL**

The UK highways Agency has established the ESDAL Project (Electronic System Delivery for Abnormal Loads) with a web-site, which seeks to co-ordinate notifications for abnormal loads. Supporting information and appropriate forms are available for download.

The address is [www.esdal.com](http://www.esdal.com).





### Scope

The purpose of this Guidance Note is to review the use of method statements in the construction of steel bridgeworks. In particular, it gives guidance on best practice for generation, review and control of the definitive form of the method statement used on site by the bridge contractor to carry out the work. The quality of that document is critical to building the bridge correctly in a safe planned manner.

### Terminology

The term 'method statement' is used widely throughout the course of a project, from concept to completion, to refer to a range of quite different documents. For clarity in this Note, the following terms are defined:

**Bridge Contractor:** the organisation, often a specialist sub-contractor, that is directly responsible for erecting the bridgeworks.

**Method statement:** any document used in some manner to describe the erection method during the course of a project, from concept to completion.

**Erection Method Statement:** the Bridge Contractor's document that he uses for implementing the erection method.

**Originator (of method statement):** The person, usually an employee of the Bridge Contractor, who is responsible for the whole process of drafting and bringing to issue for construction the Erection Method Statement.

The term 'Safety Method Statement' is used in some HSE publications covering construction generally to describe a document used by a contractor to set out his safe system of work for a construction activity. As described below, the Erection Method Statement covers more than this.

### Health and safety

The regulation of health and safety was rationalised in the Health and Safety at Work Act, 1974. Recognising that safety on construction sites was heavily influenced by decisions in the conceptual, detail design and procurement phases of a project, the HSE published its Guidance Note GS 28, Safe Erection of Structures (Ref 1) in 1984. For many years this set out good practice for all parties to a steelwork project, and in particular it covered the need, purpose and content of method statements in general terms. GS 28 was withdrawn in 1997

The introduction of the Construction (Design and Management) Regulations in 1994 and their revision in 2007 (Ref 2) placed the force of law on owners (Clients) and designers, as well as contractors, to have due regard to health and safety during construction, and for other phases of a project's life from inception to final demolition. The expectation of good practice became a legal requirement. Industry guidance on best practice is given in the BCSA *Guide to the erection of steel bridges*, published in 2005 [Ref 3].

The following points are basic to health and safety considerations for the methods and method statements for the erection of steel bridges:

- the designer of the bridge (as CDM defines) has to anticipate erection throughout, to ensure that erection is practicable and to minimise hazards and reduce risk as far as practicable
- the designer has to communicate unusual features, constraints and hazards, as well as his technical requirements, to the Bridge Contractor (through the supply chain)
- for any bridge project, the Principal Contractor's Construction Phase Plan (see the CDM Regulations for definitions) will require the Bridge Contractor to work to documented safe systems of work contained in a method statement
- all designers, for permanent works, for temporary works and for construction engineering, are required to cooperate with regard to health and safety.

### Erection method

A new steel bridge is the product of the combined efforts of an owner and a set of designers and contractors. From concept to completion, there is a simple sequence of activities by the participants in which erection is the culmination, if not the conclusion. Consequently:

- the erection method is inextricably linked to the permanent works design
- the method has to be anticipated in all the preceding activities
- the choice of method determines much of what goes before erection.

# Guidance Note

## No. 7.08

---

Clear communication about method is as important as the drawings and the specification – the better the communication, the better the objectives of safety, economy and quality will be met.

Method statements are used to communicate the method up and down the contractual chain, for a variety of purposes throughout the procurement and construction phases.

Changes in the steel construction industry and technical advances in equipment mean that the Bridge Contractor may employ subcontract designers for temporary works and checking, subcontract erectors, and specialists for welding, heavy lifting, jacking and movement, amongst others. These subcontractors will contribute to the development of the method as well as its implementation.

This Guidance Note is primarily concerned with the culmination of this process, the method statement prepared by the Bridge Contractor to reflect all the requirements and constraints of the contract, his own assessment of hazard and risk, and his obligations under the Health and Safety at Work Act.

### **The Bridge Contractor's Erection Method Statement**

Historically, bridge contractors' method statements have been technical documents with explicit control of safety of the works, but only implicit control of the health and safety of people.

In steel bridge building today, the Bridge Contractor's method statement has four essential functions to fulfil in setting out explicitly the plan for carrying out the work. The Erection Method Statement has to communicate:

1. clear instructions for site management and responsibilities
2. engineering instructions to site management for the work necessary to achieve the technical performance
3. the safe systems of work to undertake the potentially hazardous tasks inherent in steel erection.
4. the conduct, control and coordination of erection activities carried out by the specialist sub-contractors.

### **Production of the Erection Method Statement**

The Bridge Contractor is engaged in dialogue about his method with the other parties from the start of his contract: he also has to carry out his own design and planning for construction. Only when the method is agreed and his design is substantially finished can the Erection Method Statement be written ready for use on site - and following on his own risk assessments.

The extent of the Bridge Contractor's design will depend on the scale and complexity of the bridge and will have considered:

- choice of method
- analysis of the structure for each stage;
- design of temporary works
- selection of equipment, plant and access systems
- resolution of the requirements of the contractors, utilities, and other stakeholders.

The Originator of the erection method statement should be an engineer with the appropriate knowledge and experience; he may or may not be the senior person directly responsible for the work on site. The Erection Method Statement should be checked and reviewed internally by engineers or managers for engineering, health and safety, and project considerations. It is probable that the statement will be checked by independent engineers under the terms of the contract (e.g. for the Form C Certificate), but the Bridge Contractor should not rely on an independent review for technical validation of the method.

The Bridge Contractor needs time to consider all these matters, and the Principal Contractor must ensure that this is allowed for sufficiently in the Bridge Contractor's programme. The project programme also has to allow sufficient time for the external review of the Erection Method Statement.

### **Reviewing an Erection Method Statement**

In most projects that include steel bridge-work, the Erection Method Statement will be reviewed externally by the main contractor (Principal Contractor), the engineers responsible for the permanent works (Designer) and

for supervision of the works (e.g. the Employer's Project Manager), and by stakeholders with activity on the site (e.g. Network Rail or a river authority). **Each of them has their own responsibilities for work on the site and obligations under the health and safety legislation and these responsibilities cannot be overridden by the terms of the contract.**

It is important that each party ensures that the review is carried out by a competent person in a co-operative and expeditious manner. The purpose of the exercise is to enable the Bridge Contractor to implement his plan in the knowledge that it is sound and for each party to fulfil its role safely and efficiently.

It is recommended that each external reviewer, in applying their own knowledge, experience and concerns:

- tests the method by working through it line by line, visualising the action in detail,
- does not assume that something is correct because other reviewers have signed it off,
- is constructively critical with the question "what if?" in mind,
- refers any questions which cannot be answered and any assumptions which have to be made back to the Originator.

### What to look for in the Erection Method Statement

Faced with an Erection Method Statement for review, ask the following questions of it.

*Are the purpose and scope of the Erection Method Statement clearly expressed?*

- is it a controlled document from an effective quality management system?
- what is covered?
- what is excluded?

*Are the necessary and sufficient supporting documents referenced?*

- are there meaningful sketches and drawings of erection sequence and temporary works?

- what contract drawings and specifications are required for erection?
- are crane duties documented?
- what project-specific regulations or policies apply?

*Is health and safety policy adequately described?*

- is the contractor's safety policy invoked?
- are special hazards identified (e.g. power lines and hazardous products), and are procedures to deal with them in place?
- who is responsible for safety on the site for these works?
- are generic work procedures in place for common activities covering techniques and safety measures? (e.g. for tightening bolts, slinging, welding, use of hydraulic jacks)
- what evidence is there of a documented risk assessment?
- have the residual risks identified in the Construction Phase Plan and the Bridge Contractor's assessments been allowed for?

*Is management of the works clearly identified and assigned?*

- who is in charge of the works?
- who specifically is in charge of each critical operation? (e.g. crane lift, launch, jacking operation)?
- what are the arrangements for control and communication for each critical operation?
- are responsibilities for interfaces and supporting or dependent activities defined? (e.g. with the Main Contractor or Engineer's Representative)
- are there formal arrangements for coordination with all on site?
- are handover or permit-to-work procedures defined?
- what engineering back-up is provided to deal with unforeseen problems?

# Guidance Note

## No. 7.08

---

*Are the site, the structure and the logic of the scheme adequately described for a competent site manager to understand the method, its constraints and limitations?*

*Is the construction logic clear and sufficient?*

- are options allowed for, or is unnecessary logic imposed?
- are hold points and acceptance criteria properly identified?

Note: It is usually most convenient if the method is set out as a series of short, well-defined phases with each phase covered by:

- a brief narrative describing (preferably in the present tense) the activity, conduct and timing from a defined start point
- a list of the necessary preparatory actions and checks including those by others
- the essential sequence of all necessary actions given as instructions in the imperative tense with all necessary qualifications (e.g. "lift ... until...")
- the acceptance criteria for completion of the phase.

*Are the preparations for each stage of operation properly described?*

- what equipment and plant are required?
- what preparations are required by others?
- are adequate contingency arrangements provided for?

*Are the instructions for each stage of operation clear, explicit and unambiguous?*

*Is the Erection Method Statement complete?*

- are all safe systems of work covered, or identified for the site manager to prepare them? (i.e. by explicit content, by the contractor's documented generic work instructions, or by site procedures for planning and risk assessment.)
- does the Erection Method Statement anticipate all known or possible hazards?
- does it take account of any relevant matters in the Construction Phase Plan?
- are the activities of the Bridge Contractor's sub-contractors identified and fully

integrated into the statement, with the necessary supporting data?

### **Acceptance**

Acceptance of the Erection Method Statement for implementation requires an established project procedure for dealing with and closing out reviewers' comments and queries, prioritised as necessary

On a subjective level, there are sometimes issues of style, undue brevity, superfluous material and presentation. The originator should be required to address these only if they are significant to the ultimate use of the document.

Having completed a review there are two acceptance criteria that should be tested:

- (1) Is the Erection Method Statement, with its reference documents, complete and sufficient for a competent site manager with no previous information to implement it as a safe system of work? (It is not unknown for personnel to be introduced to a project, especially on small bridges, at a late stage.)
- (2) If challenged, can the originator and the reviewers demonstrate from the Erection Method Statement how it satisfies all the technical, safety and management requirements? (One could be faced with a lawyer!) A documented record of review/comment is most effective in this regard.

### **Change control**

The Erection Method Statement is finalised and submitted for review near the end of the contractor's design and planning work, so that it will reflect fully the conditions under which the work is done. It is inevitable, however, from the nature of civil engineering construction that plans change – preceding work may be delayed, access may be lost after bad weather, major plant may become unavailable – in which case the method statement will require revision, unless such change is anticipated by options in the text.

As for any other controlled document, change to the Erection Method Statement would be carried out by the Originator and would undergo the same review process as

before. This may need to be dealt with urgently: a change can be required at the last minute, yet be a very practical problem that needs understanding and co-operation to expedite the solution whilst maintaining the integrity of the construction process.

### **NOTE**

**The Erection Method Statement is a vital document in bridge building; it is the Bridge Contractor's document, but it requires the whole project team's contribution to ensure its validity; a large part of the value of preparing and reviewing a Method Statement is acquired during the process itself.**

### **References**

1. Health and Safety Executive, Guidance Note GS 28, HMSO, 1984 (*withdrawn Dec 1997*).
2. Managing health and safety in construction, CDM Regulations 2007, Approved Code of Practice. HSE Books 2007.
3. The British Constructional Steelwork Association, BCSA Guide to the erection of steel bridges (publication 38/05), 2005.



**Scope**

This Guidance Note covers some of the considerations that are needed in the design, detailing, fabrication and assembly of bridge steelwork to ensure that the protection against corrosion is not compromised by inadequate preparation, damage, or an unnecessarily severe local environment.

The selection of a protective coating system is outside the scope of the Note - see References 1 & 2 for guidance on that aspect.

General information on alternative protective treatments is given in the following Guidance Notes:

- GN 8.03 Hot dip galvanizing
- GN 8.04 Thermally sprayed metal coatings
- GN 8.05 High performance paint coatings

**General**

The application of a protective coating system is the most common way of controlling corrosion. However, the effectiveness of the system depends not just on the coating materials and specified application procedures, but also on the initial surface condition, the access for application and the environment under which the work is done.

**Initial surface condition**

For new works, it is wise to specify that the surfaces shall comply with rust grades A or B according to EN ISO 8501-1 (Ref 3). Material that is pitted, i.e. rust grades C or D, should be avoided if at all possible, since it is difficult to prepare such material sufficiently to clean all the corrosion products from the pits in the surface.

**Surface preparation**

The presence of even small amounts of surface contaminants, oil, grease, oxides etc. can physically impair and reduce coating adhesion and these should be removed before abrasive blast cleaning or mechanical preparation. (It is erroneous to think that subsequent blast cleaning operations will remove such contaminants and it is bad practice to permit them to remain on the surface).

Similarly, millscale on new steelwork is unsuitable for modern high performance coatings and must be removed. This is usually achieved by abrasive blast cleaning to Grade Sa 2½ or Sa 3 as defined in EN ISO 8501-1 (ref 3), depending on the exposure, the coating system and the requirements of the designer.

In addition to the degree of cleanliness, surface preparation also needs to consider the 'roughness' appropriate to the coating to be applied. For example, shot abrasives produce a rounded surface profile and are used for thin film paint coatings (rarely used on bridges), whereas thick or high build paint coatings need a coarse angular surface with a high profile, as provided by grit abrasives, to give a mechanical key.

The surface treatment specification therefore should describe the abrasive to be used and the roughness required, usually as an indication of the average amplitude achieved by the blast cleaning process, and state a method of measurement e.g. comparator panels, special dial gauges or replica tapes. Usually, comparators or replica tapes are used. The comparators are covered by EN ISO 8503-1 (Ref 4). The replica tape method, which is more widely used, is covered by EN ISO 8503-5 (Ref 5).

After abrasive blast cleaning, it is possible to examine for surface imperfections and changes to surface conditions caused during fabrication processes, e.g. by welding.

It may be necessary to remove general surface imperfections on welds and cut edges to produce an acceptable surface condition for coating.

Weldments on fabricated structural steelwork represent a relatively small but important part of the structure and can produce variable surface profile and uneven surfaces or sharp projections that can cause premature failure of the coating. Although welded areas are inspected, the requirements for weld quality do not usually consider the requirements for coating. Welds must generally be continuous and always free from pin holes, sharp projections, excessive undercutting and weld



# Guidance Note

## No. 8.01

---

spatter. Any sprayed coatings used in inspection (e.g. those used in MPI) need to be removed as well. The treatment of welds, cut edges and other areas is covered in EN ISO 8501-3 (Ref 6).

After the preparation of the surface to an acceptable standard of cleanliness and profile, it is important that the steelwork has no residual dust or particulate matter on the surface and is not allowed to deteriorate. Re-rusting can occur very quickly in a damp environment and unless the steel is maintained in a dry condition coating of the surface should proceed as soon as possible. Any significant re-rusting of the surface should be considered as a contaminant and be removed by re-blasting.

### **Corners and cut faces**

Sawn and flame-cut ends and edges need treatment to ensure that the coating adheres and is of sufficient thickness.

At outside arrises (i.e. the meeting between two surfaces), there is a potential problem when there is a sharp (i.e. 90°) edge, because the fluid coating will not cover it properly. Consequently, they should be smoothed by grinding or filing. It is generally considered sufficient to smooth the corner to a radius of about 2 mm; chamfering to 45° is also effective, but it is difficult to avoid leaving some sharp edges when attempting this with hand tools. It can be argued that with modern high-build coatings and the use of stripe coats, smoothing to a 1 mm radius is adequate. Network Rail specifies a minimum radius of 3 mm and this is considered by some fabricators to be an onerous requirement.

In addition to the requirement for smoothing arrises, the SHW, clause 1914(13) (Ref 1), specifies the application of one or more stripe coats (an extra coat applied only locally) for all external corners (and for welds and fasteners, for a similar reason).

The corners of rolled sections generally do not require grinding, as they are usually smooth as a result of the rolling process.

For the treatment of flame-cut surfaces, which are harder than the rolled surface, refer to GN 5.06.

### **Site connections and splices**

Girder splices and connection details are often not given full protection in the shops, leaving the connection zones to be made good on site. A frequent consequence is that these zones are the least well prepared and protected, and are the first to show signs of breakdown.

### *Welded connections*

At welded connections, the key factors in ensuring the effectiveness of the coating system are the effectiveness of the protection before final coating. The areas locally to welds are usually masked, to prevent them being coated. The masking stays in place until the joint is welded; this is not an ideal protection if there is prolonged exposure before welding.

After welding, it is essential that the joint surfaces, including the weld itself, are prepared to the specified standard of cleanliness and profile. Because of the contamination that occurs from the welding flux, particular attention needs to be paid to cleaning off all residues.

The surfaces of welds themselves should not need any grinding if they comply with the requirements of EN 1011-2: 2001 (Ref 7) for smoothness and blending into the parent metal. Rough profiles, badly formed start-stops, sharp undercut and other defects such as adherent weld spatter should be removed by careful grinding, such that the weld is not compromised. Particular attention needs to be paid to the blast cleaned profile, because weld metal is harder and site blast cleaning is more difficult than shop blasting.

### *Bolted connections*

Bolted connections, which are almost always preloaded slip-resistant connections, merit particular consideration, both of the surfaces that will remain exposed and of those that will not (i.e. the faying surfaces). Attention should be paid to the removal of any adhesive used on the protective films for the faying surfaces, and to the removal of any

lubricants used on the threads of bolts. Care should be taken to avoid contamination of surfaces during bolting up, for example, older air-power wrenches tend to produce a fine oily/misty exhaust that may settle on the surface.

### **Damage during handling**

During handling, turning and assembly, damage to edges and to surfaces by the use of sharp-toothed clamps must be avoided by taking precautionary measures, such as the use of properly designed lifting cleats. If damage does occur, it must be carefully blended out by grinding (and the full protective treatment restored, with specified overlaps between coats).

### **Cleanliness at site**

Just as surface cleanliness before first coating is fundamental to performance of the system, so is the cleanliness of painted surfaces prior to the application of subsequent coats. On site, thorough cleaning shortly before painting is always necessary to remove contamination accumulated over time and from construction activities including dust, grout leaks from concreting, and the products of blast-cleaning, bolting and welding.

### **Access for application of coating**

Since the effectiveness of a coating depends on the preparation and the proper application of the coating, it is essential that the preparation, application and inspection are straightforward. Narrow gaps, difficult to reach corners, and hidden surfaces should therefore be avoided wherever possible.

### *Cope holes*

A typical detail that is difficult to protect is a cope hole in a web stiffener. Unless the hole is very large, it is virtually impossible to blast clean the surface properly, and to apply a protective treatment to the surface. (A fluid coating can only be applied by 'bouncing off' other surfaces, and it is totally impossible to apply metal spray.)

If cope holes are used, they should be circular and of at least 40 mm radius, preferably more. (If the cope hole were formed by a 45° snipe, the weld would not be returned

through the hole and there will be the additional problem of a narrow crevice - such a detail should not be used at all.)

There is an argument for using a cope hole in a web stiffener that is fitted to the bottom flange, to provide a drainage path along the flange. The benefits are, in most cases, marginal, and the action of channelling water past surfaces that have probably been less well protected than they should have been is questionable.

The best detail at the inside corner of a web stiffener is a small snipe, just sufficient to clear the web/flange weld, so that the stiffener fillet weld can be continued round the corner, completely sealing the junction.

### *Interfaces*

There are two common types of interface in steel and composite bridges - the faying surfaces of a slip-resistant bolted joint and between a steel flange and a concrete deck slab.

Faying surfaces are usually either unpainted or metal sprayed without sealer. They need to be protected (usually by masking tape) until the parts are finally bolted together (see GN 7.05).

Surfaces in contact with concrete are usually (with the exception of a marginal strip at the edges of the interface) blast cleaned bare steel. The marginal strip should be treated as for the external surfaces, except that only the shop coats need be applied. It is recommended that the width of the marginal strip should be at least equal to the required cover to the reinforcement, for the same exposure condition. A width of 50 mm is common. Any aluminium metal spray on surfaces in contact with concrete needs to receive at least one coat of paint, to prevent the reaction that may occur between concrete and aluminium. It is recommended that any shear connectors be positioned such that they (and their welds) do not lie within the marginal strip; they should also be protected against overspray of the coating.

In both cases, the perimeter of the interface needs to be considered carefully, since water

# Guidance Note

## No. 8.01

---

may penetrate through capillary action. It is usual to specify that a margin inside the interface is also coated; this does not compromise the bonding of the concrete or the friction capacity of the joint. Joints may also be sealed with a suitable high quality alkali resistant mastic.

### *Narrow gaps*

Sometimes narrow gaps are created between two steel elements. These will be very difficult to maintain properly and should be avoided if at all possible. If there are narrow gaps, they should be sealed, either by welding or by proprietary sealants, and covered by the protective coating.

### *Bolts, nuts and washers*

The exposed surfaces of bolted fasteners need to be protected to at least the same level as the rest of the steelwork. Indeed the crevices associated with these fasteners are particularly vulnerable. Short-term protection of the fastener can be obtained by the specification of a sherardized or electroplated coating, but the full coating system should be applied after assembly. Hot dip galvanized fasteners are commonly specified; they should be overcoated after assembly. The SHW requires stripe coats to be applied to all fasteners, including washers. See GN 8.02 for further details on protective treatment of bolts.

### *Moisture and dirt traps*

In detailing the steelwork, avoid any features that would hold or trap water and dirt. For example: avoid arranging channels with toes upward; arrange angles so that the vertical leg is below the horizontal. As a last resort, if features that trap water or dirt cannot be avoided, provide drainage holes, but ensure that they are large enough to be coated properly and kept clean, and that they do not discharge onto other vulnerable areas.

### *Access for maintenance*

Remember that the bridge will have to be maintained and that the coating will need to be renewed during the life of the bridge. This can only be done effectively if there is good access, both for personnel and for the process of cleaning and recoating. Avoid

creating details where this would be difficult or impossible in the assembled configuration.

Further advice on design considerations is given in references 8 and 9.

### References

1. Manual of Contract Documents for Highway Works: Specification for Highway Works, series 1900; Notes for Guidance on the Specification for Highway Works, series NG1900, TSO, 2005.
2. Corrosion Protection of Steel Bridges, Corus, 2005.
3. EN ISO 8501-1:2007 Preparation of steel substrates before application of paints and related products. Visual assessment of surface cleanliness. Rust grades and preparation grades of uncoated steel substrates and of steel substrates after overall removal of previous coatings.
4. EN ISO 8503-1:1995, (BS 7079-C1:1989) Preparation of steel substrates before application of paints and related products. Surface roughness characteristics of blast-cleaned steel substrates. Specifications and definitions for ISO surface profile comparators for the assessment of abrasive blast-cleaned surfaces.
5. EN ISO 8503-5:2004, (BS 7079-C5:2004) Preparation of steel substrates before application of paints and related products. Surface roughness characteristics of blast-cleaned steel substrates. Replica tape method for the determination of the surface profile.
6. EN ISO 8501-3:2007 (BS 7079-A3:2006) Preparation of steel substrates before application of paints and related products. Visual assessment of surface cleanliness. Preparation grades of welds, cut edges and other areas with surface imperfections
7. EN 1011-2, 2001, Welding. Recommendations for welding of metallic materials. Arc welding of ferritic steels.
8. EN ISO 12944 Paints and varnishes. Corrosion protection of steel structures by protective paint systems.
9. Design of steel bridges for durability, The Steel Construction Institute, 1997.

**Scope**

This note covers the various metal coatings that are applied to bolts used in bridgework, and the practical aspects to be considered.

**Why apply metal coatings to bolts?**

With the exception of structures of weather resistant steel (WRS), the long-term corrosion protection to bolt groups in bridge structures is given by the full coating system. (For WRS steel structures the bolts, nuts and washers should be of WRS material and are not given any protective treatment, unless the steelwork is painted for some reason.)

Threaded components are very difficult to blast clean effectively, and even more difficult to metal spray effectively. The normal and recommended approach is therefore to procure bolts that are protected by metal coatings during manufacture in order to avoid blasting and metal spraying of bolted joints in the assembled steelwork.

The metal coating provides primary protection during construction until the rest of the coating system is applied. (For a major structure, this may involve a long period of exposure for the metal coating.) Thereafter, the metal coating provides additional protection, depending on its thickness, in the event that the paint system suffers local breakdown in the long term; it also offers continuing protection to the concealed surfaces of the bolts.

**Beware of cadmium coatings**

Cadmium plating was frequently specified and used up to the early 1990s. It is now prohibited for health and safety reasons. Cadmium is highly toxic if vaporised; this could happen if a cutting flame or welding arc came into contact with a cadmium-coated surface.

On earlier structures, even when zinc electroplated coatings were specified, it was common for fabricators to seek and be granted a concession to use zinc-plated bolts with cadmium plated nuts, it being well known that such a combination gave lower thread friction and reduced tightening problems.

Extreme caution is therefore necessary when dealing with any bolted connections made before 1995, as cadmium may be present even if the original specification suggests otherwise.

**Zinc coatings used in bolt manufacture**

There are three methods of applying zinc coatings to fasteners:

- Electroplating
- Sherardizing
- Hot dip galvanizing

BS EN 14399 does not specify a standard for electroplating or sherardizing and leaves the coatings to be negotiated with the manufacturer.

*(1) Electroplated zinc coatings*

The coating of zinc is applied by the electrolysis of an aqueous solution of a zinc salt. The minimum local thickness typically used in bridge construction is 8  $\mu\text{m}$ .

As a precautionary measure, the Specification for Highway Works (SHW) (Ref 1) requires that any electroplated bolts are heat treated to drive out any possible entrapped hydrogen, because of the danger of hydrogen embrittlement<sup>‡</sup> during the plating process. Current practice is to follow BS 7371-3 (Ref 2), which states that bolts of property class 8.8 do not need to be de-embrittled, but property classes where the tensile strength exceeds 1040 N/mm<sup>2</sup> must be de-embrittled (this may require a formal Departure from Standard). Bolts of grades higher than 8.8 are not normally electroplated.

Chromate passivation is essential for all zinc electroplated components. It is a process by which the surface of the zinc coating is

---

<sup>‡</sup> Hydrogen embrittlement results from the absorption of monatomic hydrogen during the plating process. After installation, and under load, hydrogen atoms can migrate to dislocations in the crystal structure of the metal where they can gather to form gaseous hydrogen, which generates very high levels of internal stress. This can lead to a catastrophic failure of the fastener. Such breakages can occur hours or even weeks after tightening.

# Guidance Note

## No. 8.02

---

converted to extend its life. There are four levels of passivation. If no passivation is applied, zinc salts of a powdery appearance will form on the surface very quickly. This is known as white rusting. The use of chromate is frowned upon for environmental and safety reasons.

The SHW, Series 1900, states that chromate passivation shall not be applied to electroplated bolts which are to be painted. The reason behind this is that many commonly used paint systems will not adhere to zinc-coated surfaces without some form of etching to that surface. The higher levels of chromate passivation can resist such an etching process. Current practice is to apply a basic passivation (designation A, Table 3 of BS 7371-3) to ensure that the bolt arrives on site in a reasonable condition. Class A is the lowest level of passivation, which will not resist a subsequent etching process and which should therefore be deemed to be compliant with the SHW.

The thickness of the coating is such that no special measures are required with respect to thread clearance.

The SHW calls for all zinc plating of bolts up to 36 mm diameter to be carried out in accordance with BS 3382 (Ref 3). The maximum bolt size covered by that standard is  $\frac{3}{4}$  inch and therefore the maximum standard metric bolt size covered is M16. The majority of bolts used in bridgework are of larger diameter. Despite the wording of the SHW, the common approach for bolts over 20 mm diameter is to supply to BS 1706:1960 (Ref 4). Note that the 1990 revision to BS 1706 cannot be used as it was converted from a specification to a method of specifying.

Specifying zinc electroplated bolts to BS 7371-3, grade Zn8A, or to BS EN ISO 4042 (Ref 5), grade Fe/Zn 8c1A, would avoid the use of obsolescent codes. BS 7371-3 was published in 1993 and BS EN ISO 4042 in 2000; both cover bolt diameters up to 64 mm, which comfortably covers the range of sizes normally used in bridge construction.

### *(2) Sherardized coatings*

Sherardizing is a diffusion process in which the components are heated in close contact with zinc dust. The process is normally carried out in a slowly rotating and closed container at a temperature in the region of 385°C.

The resulting coating has a matt grey appearance. Orange staining may become apparent on sherardized coatings early in their exposure, but this is not detrimental to their performance.

Sherardizing tends to be used mostly to protect higher tensile steels (greater than 1000 N/mm<sup>2</sup>), to avoid the risk of hydrogen embrittlement (which can occur with electroplating). It is also the normal treatment for direct tension indicators<sup>†</sup>. Note that sherardizing is only suitable for protecting higher tensile steels if the method of cleaning the bolts prior to sherardizing is mechanical. (For grades 10.9 and above, if the method of cleaning is acid pickling, there is a risk of hydrogen embrittlement.)

Sherardized assemblies for preloading must be passivated to remove loose dust from the threads of bolt the bolt and nut; dust could cause problems when tightening to achieve the preload.

The thickness of the coating requires the nut to be over tapped to create sufficient thread clearance. (See Section 7 of BS 7371-8 for details.)

For bridgework, Class S1 coatings to BS 7371-8 (Ref 6) are normally specified. This gives a coating of minimum thickness 30 µm.

### *(3) Hot dip galvanized coatings*

Bolts and nuts are dipped in molten zinc and then centrifuged to remove excess zinc. Such products are commonly referred to as spun galvanized.

Hot dip galvanizing provides the highest level of corrosion protection as it gives a consid-

---

<sup>†</sup> DTIs can also be 'mechanically galvanized', with a coating thickness of 55 µm.

erably thicker coating than either sherardizing or electroplating

The galvanizing process does not cause hydrogen embrittlement, but embrittlement can be caused by acid pickling, which is used to clean the bolts prior to galvanizing. There is no problem for bolts up to and including grade 8.8, but for higher grade bolts only mechanical cleaning can be used.

High temperature galvanizing is now available from some manufacturers. The normal galvanizing bath has a temperature of approximately 450°C. However, it has been found that if the temperature is raised to approximately 550°C, a more even coating of zinc is achieved. By careful choice of suitable material and processing, manufacturers can ensure that the high temperature galvanizing process does not have any significant retempering effect on the bolt. This process is covered by BS EN ISO 10684 (Ref 7).

Currently, grades up to and including 10.9 can be obtained in a high temperature galvanized finish, and in sizes up to 24 mm diameter.

The major fastener manufacturers have made considerable investments in developing improved methods of galvanizing. However, extreme caution should always be exercised if galvanized bolts are procured through stockists, especially if the galvanizing is being arranged by the stockist; the process used must be identified reliably.

Passivation is not necessary on a galvanized finish.

Bolts are galvanized after threading. Nuts are over-tapped to create thread clearance. This is achieved by galvanizing the nuts as blanks and then tapping them over size after galvanizing. Although this approach results in an uncoated female thread, this will be protected by the coating on the male thread when the fastener is assembled.

Hot dip galvanizing to BS EN ISO 10684 is specified for assemblies to BS EN 14399 (Ref 8); BS 7371-6 (Ref 9) is currently speci-

fied for assemblies to other national standards. The main difference between BS EN ISO 10684 and BS 7371-6 is the degree of over-tapping to accommodate the zinc coating; whichever standard is used, the corresponding requirements for over-tapping should be observed. The minimum local thickness specified by these standards is 40  $\mu\text{m}$  and 43  $\mu\text{m}$  respectively.

### **Tightening zinc-coated preload bolts**

The tightening of zinc coated preloaded fasteners (nuts and bolts to BS EN 14399) requires special care. Zinc coated surfaces tend to bind under high interface pressure; this phenomenon is known as galling. Lubrication is essential to avoid a high proportion of bolt breakages in the latter stages of tightening.

In the UK, all bolts manufactured to BS EN 14399 are supplied in a lubricated condition K0. Furthermore, HRC assemblies to BS EN 14399-10 (TC bolts) must not have their lubrication modified in any way. Similarly, any assemblies supplied for use in either of the K-class conditions K1 or K2 must not have their lubrication modified.

The most effective and economic lubricant is tallow which for the best results should be sparingly applied to the leading threads within the nut and the face of the nut that contacts the washer.

Over-application of tallow, for example dipping complete assemblies in molten tallow, gives no advantage and can create additional problems in cleaning prior to painting.

Some specialist bolt suppliers whose products require consistent torque / tension relationships during tightening apply wax-based lubricants to plated nuts under factory conditions. These are often water-soluble and can be readily washed off after installation. Some manufacturers add a dye to the wax coating to distinguish such bolts from untreated items.

Oils and greases should not be used for the lubrication of preloaded assemblies, as there is a high risk of contaminating faying surfaces and significantly reducing slip factors.

# Guidance Note

## No. 8.02

---

### Painting zinc-coated fasteners

Most paint primers will not satisfactorily adhere directly to zinc-coated surfaces.

Two approaches are commonly used to provide a key for paint systems. The first is to fix the bolts in the structure, as supplied, and then utilise a paint system for the bolted joints that includes, as a first coat, an etch primer. The second is to T-wash the bolts before fixing.

T-wash is a solution containing phosphoric acid and copper carbonate. The phosphoric acid etches the surface of the zinc and the copper carbonate produces a blue/black surface colouration showing that the surface reaction is complete. This discolouration is not absolutely uniform and it is not necessary to try to achieve absolute blue/blackness, as long as it is clear that the solution has been applied over the whole area. Further application will only remove more zinc than is necessary.

T-wash should not be applied after installation as contamination of adjacent surfaces is inevitable and the acid content may damage them.

The data sheets from most paint manufacturers state that T-wash should be brushed on, but this is impractical for fasteners; the normal approach is to batch dip. However, care should be taken to remove the items from the solution as soon as they discolour. If the items are left in the solution for too long, the zinc will be stripped. It is also very important to rinse clean and dry the bolts thoroughly.

Some primers, other than etching materials, are now available that will give satisfactory adhesion directly on zinc plated surfaces. These provide an attractive alternative to T-wash, the use of which now creates many problems under environmental and health and safety legislation. However, it is strongly advised that adhesion tests are carried out to verify the performance of such primers prior to their use.

Alternative pre-treatments to replace T-Wash are also becoming available. Proper testing

should be undertaken before using one of these materials.

Bolts are generally supplied with a lubricant on the threads of the nut. The use of T-wash prior to assembly will remove/destroy the lubricant. Therefore, tightening methods that rely on torque should not be used, as the friction in the threads will be different from that assumed by the manufacturer and the suitability test for preloading (BS EN 14399-2).

The part-turn method of tightening (which is added as an acceptable method of tightening in the MPS, Ref 10) is a predominantly strain-control method that takes the bolt beyond its yield point. Consequently the final preload developed is not sensitive to a change in lubricant such as that caused by T-washing or by the application of tallow. Similarly the use of direct tension indicators (in accordance with BS EN 14399-9) does not rely on controlled lubrication.

### Treatment of plated bolts after installation

Normally the specification of the protective system for slip-resistant bolted joints requires surface preparation of the joint contact surfaces (faying surfaces) by abrasive blast cleaning. This should not be taken to include the bolts, nuts and washers, as they are not 'joint material'. It is less satisfactory to blast off the fasteners' coating and then reapply coatings than simply to degrease the fasteners and apply the remainder of the coating system. However, if the fasteners have only thin plating and there has been lengthy exposure that results in corrosion, then blast cleaning of the fasteners may be required.

### Recommendations

The following table gives an indication of the costs of the various types of zinc coating relative to that of the untreated fastener:

Coating	Cost
Zinc electroplated	20%
Spun galvanized	30%
Sherardized	35%

Note: The total cost of bolts is usually less than 1% of the cost of the structural steelwork.

Of the three processes, the most effective in terms of corrosion protection is spun galvanized.

It is recommended that spun galvanized bolts be specified (in accordance with BS EN ISO 10684 or BS 7371-6) wherever possible.

### References

1. Manual of Contract Documents for Highway Works, Volume 1: Specification for Highway Works, Series 1900, Protection of steelwork against corrosion, 2005.
2. BS 7371-3:1993, Coatings on metal fasteners. Specification for electroplated zinc and cadmium coatings. (Replaced by BS EN ISO 4042:2000 but remains current.)
3. BS 3382: Parts 1 and 2:1961 Specification for electroplated coatings on threaded components. Cadmium on steel components. Zinc on steel components. (Withdrawn)
4. BS 1706:1960, Specification for electroplated coatings of cadmium and zinc on iron and steel (Withdrawn)
5. BS EN ISO 4042:2000, Fasteners. Electroplated coatings
6. BS 7371-8:1998 Coatings on metal fasteners. Specification for sherardized coatings.
7. BS EN ISO 10684:2004. Fasteners. Hot dip galvanized coatings
8. BS EN 14399, High-strength structural bolting assemblies for preloading (in 10 Parts)
9. BS 7371-6: 1998, Coatings on metal fasteners. Specification for hot dipped galvanized coatings.
10. Steel Bridge Group: Model Project Specification for the execution of steelwork in bridges (P382), SCI, 2009.





#### Scope

This Guidance Note provides general information on hot dip galvanizing, its characteristics and properties, and highlights the issues designers should consider when specifying hot dip galvanizing for corrosion protection of structural steelwork.

#### General

An appreciation of the galvanizing process, and the way the coating is formed, is beneficial in terms of understanding the coating's unique characteristics, and how to use hot dip galvanizing.

Zinc coatings protect structural steel by weathering at a slow rate, giving a long and predictable life. In addition, should any small areas of steel be exposed, the coating provides cathodic (sacrificial) protection and corrodes preferentially. If large areas of steel are exposed, the sacrificial protection prevents sideways creep of rust.

Galvanizing is an effective and economic means of corrosion protection, and has many applications for steel bridges including:

- Small components subject to wear and corrosion, especially when chunky and not vulnerable to distortion.
- Bearings
- Bolts & fittings
- Parapets
- Facing panels (not stiffened)
- Expansion joints
- Standard unit bridge components for overseas transit.

#### Process and coating

The hot dip galvanizing process principally involves the formation of an impermeable layer of zinc, which is firmly alloyed to the steel substrate. This is achieved by the immersion of iron or steel articles in a bath of molten zinc.

#### Preparation

The galvanizing reaction will only occur on a chemically clean surface. Most preparation work is done with this in mind. Contamination is removed by a variety of processes. However, welding slag, paint and heavy grease will not be removed by these cleaning

steps and should be removed before the work is sent to the galvanizer.

Common practice is to degrease using an alkaline or acidic degreasing solution into which the component is dipped. The article is then rinsed and then dipped in hydrochloric acid at ambient temperature to remove rust and mill scale.

After further rinsing, the components will then commonly undergo a fluxing procedure. This procedure normally involves dipping in a flux. Alternatively, some galvanizing plants use a flux blanket on top of the galvanizing bath. The fluxing operation removes the last traces of oxide from the surface and allows the molten zinc to wet the steel.

#### The galvanizing reaction

When the clean iron or steel component is dipped into the molten zinc (at about 450°C) a series of zinc-iron alloy layers are formed by a metallurgical reaction between the iron and zinc. The rate of reaction between iron and zinc is normally parabolic with time. The initial rate of reaction is very rapid and considerable agitation can be seen in the zinc bath. The main thickness of coating is formed during this period. Then the reaction slows and the coating thickness is not increased significantly - even if the article is in the bath for a longer period. A typical immersion time is about 4 or 5 minutes but it can be longer for heavy articles that have high thermal inertia or where the zinc has to penetrate internal spaces. On withdrawal from the galvanizing bath a layer of molten zinc will be taken out on top of the alloy layer. This cools to exhibit the bright shiny appearance associated with galvanized products.

Conditions in the galvanizing plant such as temperature, humidity and air quality do not affect the quality of the galvanized coating.

#### The coating

When the reaction between iron and zinc has virtually ceased, and the article taken out of the galvanizing bath complete with its outer coating of zinc, the process is complete. In reality there is no demarcation between steel and zinc but a gradual transition through the

# Guidance Note

## No. 8.03

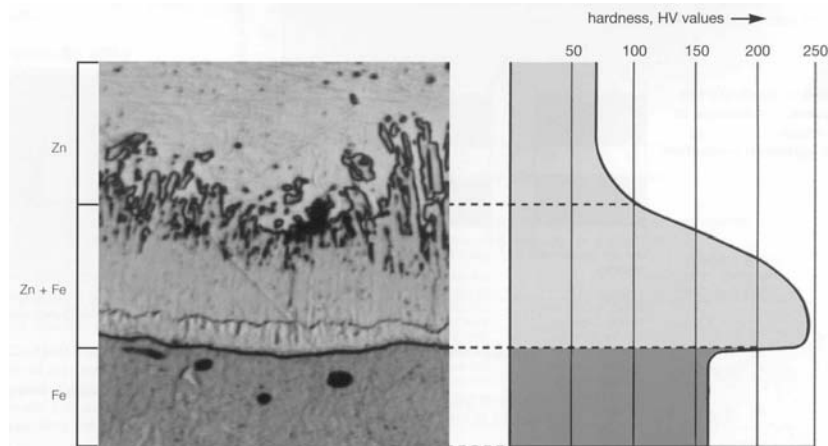

**Figure 1** *Microsection of hot dip galvanized coating and diagram of hardness through coating*

series of alloy layers, which provide the metallurgical bond.

### *Coating thickness*

Coating thicknesses are normally determined by the steel thickness and are set out in EN ISO 1461. The typical minimum average coating thickness for bridge girders is 85  $\mu\text{m}$ .

Thicker coatings may be produced by one of the following:

#### *(i) Thicker coatings by surface roughening*

This is the most common method of achieving thicker coatings. Grit blasting the steel surface to Grade Sa 2½ prior to immersion, using chilled angular iron grit of size G24, roughens and increases the surface area of steel in contact with the molten zinc. This generally increases the weight per unit area of a hot dip galvanized coating by up to 50%. Thicker coatings than those required by EN ISO 1461 should only be specified following consultation with the galvanizer or the Galvanizers Association.

#### *(ii) Using reactive steels*

A thicker zinc coating will be obtained if the article to be galvanized is manufactured from a reactive steel. The constituents in steel that have the greatest influence on the iron/zinc reaction are silicon, and phosphorous. Silicon changes the composition of the zinc-iron alloy layers so that they continue to grow with time and the rate of growth does not slow down as the layer becomes thicker.

### **Physical performance**

The nature of the galvanizing process provides a tough and abrasion resistant coating, which means less site damage and speedy erection of structures.

#### *Cohesion*

Unlike most coatings, which rely solely on preparation of the steel to obtain adhesion, hot dip galvanizing produces a coating bonded metallurgically to the steel. In other words, the iron and zinc react together to form a series of alloys that make the coating an integral part of the steel surface with excellent cohesion.

#### *Toughness*

Resistance to mechanical damage of protective coatings during handling, storage, transport and erection is very important if the cost of 'touching up' on site is to be avoided. The outer layer of pure zinc is relatively soft and absorbs much of the shock of an initial impact during handling. The alloy layers beneath are much harder, often harder than the base steel itself. This combination provides a tough and abrasion resistant coating.

### **Hot dip galvanized fasteners**

Generally, nuts, bolts and washers down to 8 mm diameter can be galvanized and a wide range of threaded components can now be processed using special equipment. For ISO metric fasteners, the galvanizing of one thread, either internal or external, requires an extra clearance of four times the coating thickness. In practice, it is normal for standard bolts from stock to be fully galvanized

but for nuts to be galvanized as blanks and then tapped up to 0.4 mm oversize and the threads then lightly oiled. When assembled, the nut thread is protected by contact with the coating on the bolt. Even after many years of service, galvanized nuts on galvanized bolts can readily be unfastened even though the threads have never been galvanized.

#### **Slip factors for slip-resistant bolted connections**

Initially, the coefficient of friction with galvanized contact surfaces is low - an average of about 0.19. As slip commences, however, friction rapidly builds up and 'lock-up' occurs due to cold welding between the coated surfaces. If a small amount of slip can be tolerated it is therefore unnecessary to treat the surfaces, but if all slip must be avoided, the coefficient of friction can be raised by roughening the surface of the galvanized coating. Wire brushing will raise it to 0.35 and a figure of up to 0.5 has been achieved by a light grit blasting or by roughening with a pneumatic chisel hammer or needle gun

#### **Welding galvanized steel**

Tests at The Welding Institute sponsored by the International Lead Zinc Research Organisation (ILZRO) have established that satisfactory high quality welds can be made on hot dip galvanized steel and that the tensile, bend and fatigue properties of such welds can be virtually identical to those of similar welds made on uncoated steel.

The Specification for Highway Works make reference to the welding of galvanized steel, and require specific procedures to be qualified. However, it is always best to remove the zinc from the fusion faces, and only consider welding galvanized steel as a last resort.

While zinc is a necessary trace element in the human diet and it does not accumulate in the human body, the inhalation of freshly formed zinc oxide fumes can cause a transient 'metal fume fever' with symptoms similar to influenza. To maintain fume levels within acceptable levels, extraction should be provided when welding galvanized steel in

confined areas, as indeed it should when welding uncoated steel.

#### **Painting galvanized coatings**

For many applications, hot dip galvanizing is used without further protection. However, to provide extra durability, or where there is a decorative requirement, paint coatings may be applied. The combination of metal and paint coatings is usually referred to as a 'duplex' coating. When applying paints to galvanized coatings, special surface preparation treatments should be used to ensure good adhesion. These include light blast cleaning to roughen the surface and to provide a mechanical key, and the application of special etch primers or 'T' wash. (T wash is an acidified solution designed to react with the surface and provide a visual indication of effectiveness.)

#### **Renovating damaged coatings**

Small areas of the coating may be damaged during construction and by operations such as cutting or welding after galvanizing. Adequate corrosion protection will be achieved at any damaged area if a repair coating is applied with a minimum thickness of 100 µm. (A lesser thickness might be acceptable when the galvanized surface is to be over-coated.) Follow guidance provided in EN ISO 1461 and datasheets available from the Galvanizers Association.

#### **The 'Zinc Millennium Map'**

The environments in most corrosion guides are necessarily general. Specific corrosivity values in the UK have been mapped by the Agricultural Development Advisory Service (ADAS). The information was based on data obtained from exposure of zinc reference samples at National Grid Reference points in a large number of 10 km square reference areas of the UK.

The results indicated varying rates of corrosion for zinc in different exterior locations in the UK. The Galvanizers Association sponsored the revision of the last map, to provide specifiers with the very latest information on zinc corrosion.

Comparison of data obtained from this latest zinc corrosion rate mapping exercise with

# Guidance Note

## No. 8.03

---

results from previous mapping programmes (1982 and 1991) show a clear, and very significant, drop in the corrosion rate for zinc for most atmospheric exposures across the UK and the Republic of Ireland.

The Zinc Millennium Map results show that a standard 85 µm galvanized coating may now achieve a coating life of more than 50 years in most environments. Similarly, a thicker 140 µm galvanized coating, often produced on structural steel, may achieve a coating life of over 100 years

### Designing articles for galvanizing

Good design requires providing:

- A means for the access and drainage of molten zinc.
- A means for venting for internal compartments.

This latter point cannot be over-stressed. The danger of not providing adequate ventilation for hollow items is that components may explode, and any explosion is likely to be in the bath of molten zinc. If in doubt, contact the Galvanizers Association.

### Size and shape

In recent years, the size and capacity of galvanizing plants has increased significantly. The longest tank in the UK is currently 21 m in length, the maximum double-dip dimension is 30m, and the maximum lift weight is 12 T. Reference should be made to the Directory of General Galvanizers for more details of the bath sizes available, and maximum lift weights, in the UK and Republic of Ireland.

Double-dipping is a special technique which may be employed to facilitate dipping when the length or depth of the item exceeds the size of the bath. However, items which have to be dipped twice are more likely to distort during the galvanizing process. Hence, if the designer is considering such techniques, then the galvanizer should be consulted, and an indication of the maximum component size should be given.

### Galvanized components in composite construction

For small spans, using rolled section beams with relatively little welded fabrication,

galvanizing may well be the preferred protective treatment. Shear stud connectors on such beams should be welded before galvanizing; the galvanized coating does not impair their structural performance at SLS or ULS.

### Steel specification

Structural steel that is to be hot dip galvanized should be clearly specified, by invoking the appropriate options in the material standards, i.e.

EN 10025 - Option 5 (Parts 1, 2, 3, 4, 6)

EN 10210-1 - Option 1.4

These options require control of the silicon and phosphorous levels.

### Distortion

If steel fabrications distort during galvanizing, this is usually due to in-built stresses being released, as the steel is heated to galvanizing temperature. Stresses may be inherent in the steel but they can also be introduced by welding, cold forming, hole punching, and flattening.

Efforts can be made at the design stage and elsewhere to minimize residual stresses, for example:

- Avoid thin plate with stiffeners.
- Arrange weld seams symmetrically. The size of weld seams should be kept to a minimum.
- Avoid large changes in structural cross-section that might increase distortion and thermal stress in the galvanizing process.
- Consider the use of intermittent welds.
- Use a staggered/balanced welding procedure.
- Ensure that work is single dipped where practicable.
- Use a symmetrical design where possible.

Intermittent welds have many advantages on galvanised structures; reducing distortion, reducing the potential for unvented voids, allowing the zinc to coat all surfaces and increasing protection.

**Potential problems, post galvanizing***Hydrogen embrittlement and strain-age embrittlement*

In the past, some problems were experienced with embrittlement of galvanized steel, from trapped hydrogen or from strain ageing. The causes of such problems are now well understood and advice is available on the avoidance of these incidents (see the information sheets referred to at the end of this Note).

*Liquid metal assisted cracking*

For some time it has been recognised that there are occasional incidences of cracking from welds or other details of structural steel members either during or immediately following hot dip galvanizing.

The occurrence of this form of cracking, known as liquid metal assisted cracking (LMAC) depends on a complex interplay of stresses, potential initiation sites, and local material conditions (e.g. hardness) when exposed to the liquid zinc. Although the phenomenon is understood in qualitative terms, since the factors that might contribute to LMAC are each subject to significant variation, the occurrence of cracks in any situation is probably best regarded in statistical terms (i.e. in what circumstances is there a significant risk).

In bridge steelwork, LMAC is rare, but the possibility of it occurring should not be entirely discounted.

Advice on the likelihood of LMAC may be sought from those with experience of the phenomenon. Advice about LMAC is also available from the Galvanizers Association.

As a minimum, it is recommended that a post-galvanizing inspection requirement be included in the project specification. Visual inspection will suffice in most cases, although MPI may be appropriate for critical details.

Finally, if LMAC occurs it may be repairable by gouging and rewelding to an approved procedure, with appropriate post weld testing. Stripping and re-galvanising after repair is not essential; the steel is not permanently embrittled. On some occasions, it may be impracti-

cal or uneconomic to carry out a repair. This could cause problems for unique components that are on the critical path for the construction programme.

**Further Information**

Guidance on the mechanism and avoidance of LMAC is available in *Galvanizing structural steelwork – An approach to the management of liquid metal assisted cracking* (published 2005). This publication is available from the BCSA and the Galvanizers Association.

The BCSA and Galvanizers Association also provide advice on galvanizing fabricated steelwork including bridges via their helpline facilities:

BCSA 020 7839 8566  
GA 0121 355 8838

**Relevant Standards**

- EN ISO 1461: 2009, Hot dip galvanized coatings on fabricated iron and steel articles - Specifications and test methods.
- EN ISO 14713: 1999, Protection against corrosion of iron and steel in structures - Zinc and aluminium coatings – Guidelines. (*due to be revised in early 2010*)
- BS 7371-6:1998, Coatings on metal fasteners. Specification for hot dipped galvanized coatings.
- EN 10244-2:2001 Steel wire and wire products. Non-ferrous metallic coatings on steel wire. Zinc or zinc alloy coatings.
- EN 10346:2009 Continuously hot-dip coated steel flat products. Technical delivery conditions.
- BS 3083: 1988, Hot dip coated corrugated sheet for general purposes.
- EN 10025 Hot rolled products of non-alloy structural steels. (Parts 1 to 6 give technical delivery conditions for the different types of steels.), 2004.
- EN 10210-1: 2006, Hot finished structural hollow sections of non-alloy and fine grain structural steels. Technical delivery requirements.

# Guidance Note

## No. 8.03

---

### **Galvanizers Association publications:**

Detailed information is available from the Galvanizers Association. Their publications include:

- The Engineers & Architects' Guide to Hot Dip Galvanizing
- The Engineers & Architects' Guide to Hot Dip Galvanized Nuts and Bolts
- Directory of General Galvanizers
- Zinc Millennium Map results
- 'GalvAction 21' information sheets (data-sheets) on a whole variety of areas including specification and design for galvanizing, renovation of damaged galvanized

coatings and interpretation of relevant standards for galvanizing

- Case histories on performance of galvanizing

### **Other references**

Manual of Contract Documents for Highway Works, Volume 1: Specification for Highway Works, Series 1900, Protection of Steelwork against Corrosion, The Stationery Office, 2005.

*Acknowledgement: this Guidance Note has been prepared with the assistance of the Galvanizers Association, who may be contacted on 0121 355 8838 (web site [www.galvanizersassociation.com](http://www.galvanizersassociation.com)).*

### Thermally sprayed metal coatings

No. 8.04

#### Scope

This Guidance Note describes the process of applying metal coatings by the thermal spray process and explains the properties of the coating system.

#### Introduction

Thermally sprayed coatings of zinc and aluminium, and more recently zinc-aluminium alloys, have been applied for many years to provide long-term corrosion protection to steel structures exposed to aggressive environments. They are an important component of the coating systems that are currently specified for steel bridges. However, note that the Highway Agency is considering removal of aluminium spray Type II from the Specification for Highway Works 1900 Series at the next revision (February 2010). Metal spray is also commonly used on steel bridge decks prior to surfacing with mastic asphalt systems.

For bridge components, the sprayed metal used for the coating is either aluminium or zinc. Aluminium is usually preferred, except for rail bridges likely to be subjected to collision damage, where zinc is recommended due to its sacrificial nature.

In atmospheric conditions of exposure, aluminium acts as a barrier coating whilst zinc provides protection by a sacrificial process. The thermally sprayed metal coating may be over-coated with paints to form a 'duplex' coating system. The combination of metal and paint in a duplex protective treatment has greater durability in comparison with that of the individual components, and also offers an opportunity to provide an aesthetically attractive finish to the structure by offering a choice of colour.

The total thickness of the selected coating system is usually determined by the required life to first maintenance.

A typical specification for thermally sprayed aluminium and zinc coating thicknesses as part of a multi-coat protection system would be a minimum of 100  $\mu\text{m}$ .

#### Coating application

Before the application of the metal coating, it is essential that the surface of the component to be coated is thoroughly cleaned to ensure that all traces of rust and mill scale are removed and to impart a suitable profile and amplitude to provide the necessary mechanical 'key' for adhesion of the coating.

Surface preparation is normally achieved by blasting with a suitable angular abrasive.

It is well established that the performance of any corrosion protection coating system is significantly influenced by the quality of the initial surface preparation. (See GN 8.01).

The metal to be sprayed can be either in powder or wire form. It is first passed through a heat source that melts the material. The hot molten particles are then projected by compressed air towards the surface to be coated. The particles impact on to the surface, flatten and solidify as overlapping platelets. The equipment used for the melting and spraying process is a hand-held gun that uses either a gas flame system or an electric arc process to provide the necessary heat.

#### *Gas flame spraying*

Metal spraying using the gas flame process is a long established practice that uses powder or wire. However, particular care must be taken to ensure that the surfaces to be treated are properly prepared, especially in areas that have been locally hardened due to flame cutting etc. The process is less tolerant to inadequate preparation than electric arc spraying.

#### *Electric arc spraying*

The electric arc process uses twin wire electrodes that are melted when positioned to form an arc produced by an applied electric current. This process affords many advantages including high speeds of application and improved adhesion to steel substrates, particularly with sprayed aluminium, compared with the gas flame process. Generally, electric arc is not considered as flexible as the gas flame process where intricate articles have to be treated or where access for the equipment is constrained.



# Guidance Note

## No. 8.04

---

Electric arc spraying gives good results on large flat areas, but tends to be relatively rough around web/flange intersections and the corners created by typical stiffener arrangements. This condition is normal and is not detrimental to the performance of the coating.

### **Sealer coat**

After the application of the metal coating, it is usual to apply a thin 'sealer' coat.

The function of a sealer coat is to impregnate the natural pores in the sprayed metal coating and thus prevent any moisture and oxygen reaching the steel surface. Sealants are therefore usually low-viscosity materials that easily penetrate the coating. They do not add significantly to the coating thickness even where several coats of sealer are applied. There are now many different types of sealers available, including those based on vinyl, phenolic and polyurethane formulations. They are readily obtainable in a wide range of colours.

'Over-thick' application is to be avoided. In the Specification for Highways Works, sealer application is specified in terms of an application rate (between 12 and 20 m<sup>2</sup>/litre).

It may be noted that sealer manufacturers state that an application rate of 20 m<sup>2</sup>/litre results in a thickness of 25 µm, but that value relates to thickness on a non-absorbent surface. It is difficult to measure the thickness of sealer after it is applied to metal spray.

Over-application of the epoxy sealer can lead to a smooth glass-like surface and adhesion problems for the first paint coat can result.

As soon as practical, and before the onset of surface deterioration, all thermally sprayed metal surfaces (excluding faying surfaces and abutting surfaces) should be coated with the sealer. Failure to do this may in certain circumstances (i.e. storage in damp or wet conditions) lead to the appearance of dark staining, which is indicative of corrosion of the substrate. In such situations, there is little recourse other than to lightly sweep

blast the surface before sealing but this is not an ideal solution.

### **Life expectancy**

#### *Aluminium*

The life expectancy of sealed, un-painted, sprayed aluminium will extend over several decades, but it is not easy to predict actual life with accuracy. The protection afforded by aluminium is due to the formation of insoluble salts produced on its surface in corrosive conditions. The inert film accounts for the low corrosion rate of the coating in most environmental conditions.

#### *Zinc*

By contrast, the durability of zinc coatings are generally predictable under known local environmental conditions. This is mainly because the coating reacts with the corroding media at a steady rate through the solubility of the zinc corrosion salts that are formed. For this reason, the life of the zinc coating is generally proportional to its thickness. Wetness and contaminants increase the corrosion rate of zinc. At discontinuities in the coating, which may arise due to mechanical damage etc. the zinc provides a measure of protection for the substrate by galvanic action; the zinc behaves in a sacrificial manner.

### **Treatment of faying surfaces at slip-resistant bolted joints**

Research has shown that reliable slip factors can be achieved with metal sprayed surfaces. However, sealers should not be applied to the faying surface, except for a small margin (10 – 15 mm) around the edges, as they will significantly reduce slip factors.

If all the steel surfaces of a component are metal sprayed, including the faying surfaces, then masking off for subsequent paint coatings is an easy matter. The steel is in a protected state and the identification and masking of faying surfaces may be done without delay to the finishing process, without undue haste and with no detriment to the eventual protection.

Subsequent paint coats should be kept completely clear of the faying surfaces. This latter margin will be properly coated when

final painting takes place, in the knowledge that the substrate is well protected. The arrangement of coating and masking for the flange of a bolted splice is shown diagrammatically in Figure 1.

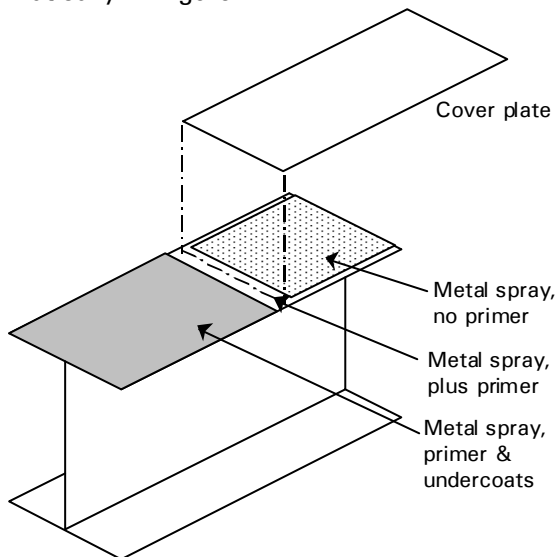

**Figure 1** *Coating and masking at a bolted splice*

#### **Repair of damaged areas and treatment at site welds**

Where the coating has become damaged, it is generally acceptable to repair the damage by locally blast cleaning followed by the application of a zinc rich epoxy paint to either zinc or aluminium thermally sprayed coatings. Similar treatment can be applied at site welded joints. For structures that are to be exposed to high service temperatures, an inorganic zinc silicate repair coating is preferred.

#### **Properties of thermally sprayed coatings**

Thermally sprayed metal coatings have several significant properties that make them suitable for application to steel structures;

- Sprayed metal coatings solidify immediately on application and, unlike paints, no drying time is involved.
- They do not sag or run and can be applied to a range of thicknesses in one operation.
- They have good handling, erection and mechanical damage resistance.

- They do not interact or harden before use in hot weather or during prolonged storage.

As a result, metal-coated components can be handled, lifted and transported as soon as required. (This contrasts with painted components, where a curing period is required.) Coating thickness can be measured as the work proceeds and thin areas rectified at once

When it is not possible to fully coat a beam that has been blast cleaned, the partially coated section can be protected whilst the remainder is re-blasted and coated, with a feathered edge on the end of the previously applied coating.

The metal coatings also offer protection to areas around slip-resistant bolted connections during the construction period, until final site paint over-coating is completed.

Additionally, the coating materials do not require the addition of hardeners, accelerators or thinners and therefore present no mixing problems. Nor do they contain inflammable solvents. However, the formation of zinc fumes does necessitate the use of personal protective equipment.

Thermally sprayed coatings are compatible with a wide range of sealers and paints. They do not suffer from degradation or embrittlement due to ultra-violet or thermal effects. Consequently, they can be over-coated with paints, etc. even after long-term exposure. (The only preparation needed is the removal of loosely adherent corrosion products by light wire brushing.)

However, there are a number of aspects that also need careful consideration.

- Thermally sprayed metal coatings in typical multi-coat protective systems are relatively expensive. They require more time and skill to apply, and need a clean surface ideally to Sa3 standard, although Sa2½ is satisfactory for zinc.
- Thermally sprayed coatings need the substrate to have an angular surface profile with a greater amplitude (in the range 75 µm to 100 µm) than other coatings.

# Guidance Note

## No. 8.04

---

- Thermally sprayed coatings are difficult to remove with blast cleaning. (But if the paint coating in a typical duplex system is properly maintained, then removal of the metal coating will not be necessary.)
- Thermally sprayed coatings are best suited to shop application, as the equipment required is bulky and cumbersome. Nevertheless, the process is used on site for 'touch-up' areas on new construction and for large areas on maintenance contracts.

### Measurement of thickness

The use of modern digital thickness gauges, on well applied and uniformly sprayed metal coatings, tends to give significantly varying readings within small test areas due to a combination of the inherent surface profile of the sprayed metal and the relatively rough grit blasted substrate.

To overcome the variation problem, a method of measurement is set out in EN ISO 2063 (Ref 2), based on averaging a set of individual readings within a test area. However, this method does not take into account the profile of the substrate when determining the coating thickness. One way of achieving a more realistic measurement of coating thickness is to take a set of initial 'profile' readings prior to spraying. The averaged value may then be discounted from the final thickness measured using the EN ISO 2063 method. Whichever method is

used, it is important to appreciate that thickness can only be assessed, rather than directly measured.

### Reference documents

1. Manual of Contract Documents for Highway Works. Specification for Highway Works, Series 1900: Protection of Steelwork against Corrosion, 2005.
2. EN ISO 2063:2005 Thermal spraying. Metallic and other inorganic coatings. Zinc, aluminium and their alloys

### Other relevant Standards and further reading

BS 4479-7:1990. Design of Articles that are to be coated. Recommendations for thermally sprayed coatings.

EN ISO 14713:1999. Protection against corrosion of iron and steel structures-zinc and aluminium coatings-Guidelines.

Corrosion Tests of Flame-Sprayed Coated Steel 19 Year Report American Welding Society Inc., Miami, Florida 33125.

Sealing and Painting of Sprayed Aluminium and Zinc Coatings. Information Sheet No. 2, Thermal Spraying and Surface Engineering Association, Warwickshire.

*Acknowledgement: This Guidance Note is based on a paper prepared by M.J.Round, The Thermal Spraying and Surface Engineering Association. (01789 842 822 and [www.tssea.co.uk](http://www.tssea.co.uk))*

## High performance paint coatings

## No. 8.05

**Scope**

This Guidance Note describes the fundamental requirements relating to the application of paint coatings for the corrosion protection of steel bridges. Metal coatings applied by hot dip galvanizing and thermal spray are covered in separate Guidance Notes (GN 8.03 and GN 8.04 respectively).

**General**

Most new steel bridges are protected against corrosion by a paint system.

Specifications for systems for road bridges are contained in the Highways Agency Specification for Highway Works 1900 Series. The current Specification includes paint-only and metal coating plus paint systems designed to provide lives to first maintenance of up to and in excess of 20 years. However, note that the Highways Agency is considering removal of the aluminium spray Type II system at the next revision (February 2010).

The paint coatings used have changed over the years, primarily as a result of new environmental legislation and in response to the demand for extended lives to first maintenance by bridge owners. The legislation has effectively limited the range of paint coatings that can be applied. Generally, the use of high solids coatings has been adopted to comply with the legislation and to improve coating durability.

Additionally, it should be appreciated that modern high performance coatings have become increasingly more specialised and need to be correctly applied to optimise properties.

Paint coatings are complex chemically engineered products formulated to have specific properties to satisfy durability and appearance requirements.

The number of coats of paint in modern specifications is less than in previous specifications with the old 5 and 6 coat systems being replaced by 2 and 3 coat systems that effectively reduce time in the paint shop and enable quick completion of the work.

Specifications for the protection of new highway bridges now typically include epoxy 'build' coats with polyurethane or epoxy/acrylic finishes.

Single high-build coatings, where correctly applied, have also indicated good long-term performance on bridge structures, suggesting a very long life to first maintenance.

However, it is important to appreciate that the overall performance of a coating system is dependent upon good workmanship at all stages of the surface treatment process, including substrate preparation, coating application and final inspection. Each stage must be carried out according to the requirements of the specification and in compliance with the information provided in the paint manufacturer's datasheets.

**Surface preparation**

It is vital to prepare the surface of the steel properly before the application of any coating. The performance of a coating is significantly influenced by a number of issues, including surface cleanliness, profile and the preparation of welds and cut edges. See GN 8.01 for further guidance.

**The protective paint system**

Modern coating systems usually consist of a sequential coating application of paints applied directly to prepared steel substrates or, in a duplex system, over metal coatings.

Conventionally, protective paint systems consist of primer, undercoat(s) and finish coats. Modern specifications typically comprise three coat systems. Each coating 'layer' in any protective system has a specific function.

It is usual for the primer and undercoats to be applied in the shop and untreated areas (such as bolted splices, site welds) brought up to the shop coating state before finish coats are applied on site.

The individual coats of paint are now described.

**Primer**

The primer is applied directly onto either the cleaned steel surface or, in the case of du-

# Guidance Note

## No. 8.05

---

plex systems, the sealed metal coating. Its purpose is to wet the surface and to provide good adhesion for subsequent coats. In the case of paint-only systems, primers are sometimes also required to provide corrosion inhibition.

There are two basic types of primer:

*(i) Primers pigmented with metallic elements anodic to steel.*

These primers are formulated so that, when a break in the coating (due to damage or local corrosion) exposes the steel substrate, the anodic metal corrodes sacrificially in preference to the steel. This effectively stifles steel corrosion and under-rusting of the primer until the anodic metal is exhausted. Zinc-rich primers are the most commonly used of this type.

*(ii) Primers relying on the high adhesion and chemical-resistance properties of the binding media.*

With these primers, good adhesion is obtained (provided that the surface is very thoroughly cleaned) and it is sufficient to prevent under-rusting at any break in the coating (due to damage). Two-pack epoxy primers are typical of this type. These primers may contain inhibitive pigments to interfere with the corrosion process. Zinc phosphate, for example, is a mildly inhibitive pigment and is widely used in modern primer formulations.

*Undercoat(s) (intermediate coat(s))*

Intermediate or undercoats are applied to build the total film thickness of the system. Undercoats are specially designed to enhance the overall protection and, when highly pigmented, to decrease permeability to oxygen and water. Generally, the thicker the coating the longer the life, as the path length for moisture and oxygen through the film is longer.

The incorporation of lamellar pigments, such as micaceous iron oxide (MIO), reduces or delays moisture penetration in humid atmospheres by increasing the path length and improves tensile strength.

Modern specifications now include inert pigments such as glass flakes to act as lamellar pigments. Undercoats must remain

overcoatable even when there are unavoidable delays in applying them and the finish coats.

*Finish coat(s)*

The finish coat provides the required appearance and surface resistance of the system. Depending on the conditions of exposure, it must also provide the first line of defence against weather (i.e. sunlight, open exposure) and condensation (as on the undersides of bridges).

*Stripe coat*

Stripe coats are additional coats of paint that are applied locally to welds, fasteners and external corners. Their function is to build a satisfactory coating thickness at edges and corners where paint has a tendency to contract and thin upon drying. Specifications should indicate the type and number of stripe coats required and state when they are to be applied. Stripe coats, and indeed most intermediate coats, are specified in contrasting colours to aid application and inspection.

**The paint system**

The various superimposed coats within a painting system have, of course, to be compatible with one another. They may be all of the same generic type or may be different, e.g. chemical resistant types, such as a recoatable polyurethane finish coat, may be applied onto epoxy primer and intermediate coats. However, as a first precaution, all paints within a system should normally be obtained from the same manufacturer; they must also be used in accordance with that manufacturer's recommendations.

**Coating thickness**

The coating thickness (both overall and of individual layers) is an important factor in the performance of the coating system. Specifications usually quote minimum dry film thickness, although they usually also require that the application avoids excessive film thickness. The over-application of paints can result in the formation of high stresses and may cause premature failure of the system. Guidance on the measurement of coating thickness is given in GN 8.06.

### **The application of paints**

The method of application and the conditions under which paints are applied have a significant effect on the quality and durability of the coating. Standard methods used to apply paints to steel bridges include airless and air assisted spraying, plural component spraying and brushing.

For airless spraying, the paint is hydraulically compressed and, when released through a small orifice in an airless spray gun, it is atomised and projected onto the surface. By changing the orifice size and shape and by varying the hydraulic pressure, atomisation can be accomplished for a wide range of paint consistencies from thin to thick, to give a wide range of rates of deposition. The equipment required is much more expensive than for air-assisted spraying, because it must withstand the much higher pressures involved. Hydraulic pressures up to 280 bar may be required.

A variant of airless spraying involves heating to reduce the viscosity of the paint rather than adding diluents. In this way, greater film thickness per application is achieved. This method can be used for the application of solvent-free materials such as two-pack products that can be mixed at the spray gun nozzle at the moment of application. The use of expensive equipment and highly skilled labour is necessary for the achievement of optimum results but is justified for the protection of large and important structures.

### **Conditions at application**

The principal conditions that affect the application of paint coatings are temperature and humidity. These can be more easily controlled under shop conditions than on site.

#### *Temperature*

Air temperature and steel temperature affect solvent evaporation, brushing and spraying properties, drying and curing times and the pot life of two-pack materials, etc. Where heating is required, this should only be by indirect methods.

#### *Humidity*

Paints should not generally be applied when there is condensation present on the steel

surface or the relative humidity of the atmosphere is such that it will affect the application or drying of the coating.

However, moisture cured paints are available. These paints are specifically formulated for application in damp and humid conditions; reference should be made to the manufacturer's data sheets for details of limiting conditions of application.

### **Inspection and testing of paint coatings**

It is essential that all of the stages of surface preparation and coating are inspected by an appropriately qualified person. The importance of inspection cannot be overstated. It is very important to the achievement of long-term performance to ensure that the coated structure has been correctly treated according to the specification and coating manufacturers' data sheets.

See GN 8.06 for further information about inspection of coatings.

### **Reference documents**

1. Manual of Contract Documents for Highway Works Specification for Highway Works, Series 1900: Protection of Steelwork against Corrosion, 2005.

### **Other relevant Standards and further reading**

EN ISO 8501-1:2007, Preparation of steel substrates before application of paints and related products. Visual assessment of surface cleanliness. Rust grades and preparation grades of uncoated steel substrates and of steel substrates after overall removal of previous coatings

EN ISO 8503-1:2007, Preparation of steel substrates before application of paints and related products. Surface roughness characteristics of blast-cleaned steel substrates. Specifications and definitions for ISO surface profile comparators for the assessment of abrasive blast-cleaned surfaces

Corrosion Protection of Steel Bridges, Corus, 2005.



### The inspection of surface preparation and coating treatments

No. 8.06

#### Scope

This Guidance Note describes the fundamental requirements relating to the inspection of surface preparation and coating treatments applied to steel bridges. It is intended to provide an appreciation of the need for total inspection throughout all of the stages associated with application of surface treatments for durability and appearance.

#### General

Most new steel bridges in the UK are protected in accordance with specifications contained in the Highways Agency Specification for Highway Works, 1900 Series (Ref 1). Sometimes, client-designed specifications may be required instead, but whichever is to be followed, the basic principles for adequate surface preparation and the correct application of the protective coatings should be common.

It is important that, whatever the source of the specification, the required parameters/values should be clearly set out. In the instances where there are different methods available to check those parameters/values the method of checking and the interpretation should be made clear.

The employment of an appropriately experienced and/or qualified paint and coating inspector is essential to monitor for compliance with any specification, to record essential data and to advise where any non-conformances are found.

One recognised qualification scheme currently available is that certified by the Institute of Corrosion. This international scheme is available for the qualification and certification of industrial painting and coating inspectors and operates in accordance with EN ISO/IEC 17024 (Ref 2).

The inspector should have recourse to all of the equipment for testing and measuring the specified parameters plus the relevant standards for reference.

The absence of a properly conducted inspection regime at the preparation and application

stages can account for a significant number of the premature coating failures experienced in service. The costs associated with remedial treatment for coating systems that fail prematurely are well in excess of the costs for proper inspection.

#### Definition and requirements

The term 'inspection' is defined in EN 45020 (Ref 3) as the "evaluation for conformity by observing, testing or gauging the relevant characteristics"

Additionally, the evaluation for conformity is defined as "systematic examination of the extent to which a product, process or service fulfils the specified requirements".

#### Surface preparation

The performance of a coating is significantly influenced by a number of characteristics of the substrate surface including: its condition before treatment; its post-treatment state of cleanliness and surface profile and surface imperfections on welds and cut edges. All of these directly affect the adhesion of the protective coatings. See GN 8.01 for further guidance.

Surface preparation is the essential and most important first stage treatment of a substrate. There is little point in continuing with the application of the coating(s) if there is failure to achieve a satisfactory surface condition.

The importance of checking that surfaces are adequately cleaned and profiled to receive the subsequent coating cannot be overstated.

#### Conditions at application of coating(s)

A basic requirement of all specifications is that the conditions of temperature and humidity are favourable for the application of the coating.

Normal practice is to measure the steel temperature with a contact thermometer and the humidity by using a whirling hygrometer. The dew point may be calculated from the readings obtained. It is usually specified that



# Guidance Note

## No. 8.06

---

the steel temperature should be maintained at least 3°C above the dew point (except for moisture-cured paints).

Records of all parameters should be kept along with dates, times and signature of the inspector.

These records may be used as a basis for future maintenance programmes and are also essential to provide data in the event of premature coating failure.

### **Inspection and testing of metal coatings**

The inspection of metal coatings is usually straightforward. A visual check is made on the condition of the surface and measurements are taken of the coating thickness.

For thermally sprayed coatings, the inspector should check that the surface is uniform in texture without coarse, lumpy or powdery deposits. Any damage to the coating should be noted and further checks made on repairs, which should be made by an agreed method (see GN 8.04).

For hot dip galvanized coatings, the inspector should check that the surface is uniform in appearance and reasonably smooth. Variations in colour and texture are acceptable, because these vary according to the steel chemistry and processing. The appearance of uncoated areas, flux and ash inclusions, distortion and damage may be causes for rejection. Any defects that are repairable should be noted and further checks made on the repairs. (For guidance on repair of galvanized coating, see GN 8.03.)

### **Metal coating thickness measurement**

The thickness of metal coatings is measured using standard non-destructive methods (e.g. an electromagnetic induction paint thickness gauge). There may also be a specified requirement for adhesion testing for thermal sprayed coatings. More information can be found in EN 22063 (thermal sprayed coatings) and EN ISO 1461 (hot dip galvanized coatings).

### **Inspection and testing of paint coatings**

Paint coating systems are usually multi-coat systems and it is important to make checks

at each coating stage. Visual checks should be made for obvious coating imperfections and defects. Measurements of coating thickness should be made on both wet and dry film thicknesses during and after the paint application process. In addition, there is sometimes a requirement to undertake other tests such as for adhesion and porosity or pinholes.

### **Measurement of paint coating thickness**

#### *Wet film thickness*

Wet film thickness (wft) checks are usually required during the application of the coating to check that a subsequent satisfactory dry film thickness will be achieved. The most common instrument is the wet film comb. Disposable plastic types can be used once only, to speed measuring.

#### *Dry film thickness*

An important factor in the inspection of the coating system is the measurement of the dry film thickness (dft). Dry film thickness is generally measured on the complete paint system, although individual films may be required to be checked separately as application progresses (minimum values for each coat are usually stated in specifications).

As mentioned previously, what the specified dft is and actually means should be clear in the specification. It must be appreciated that most dft gauges can be calibrated in various ways and that different methods of calibration may give different values on the same surfaces being checked.

One common method of measuring dft is to use a calibrated digital electromagnetic induction paint gauge. The accuracy of the gauge should be checked periodically during use against calibrated thickness shims.

If an electromagnetic gauge is used on a coating over a blast cleaned substrate, the dry film reading will not take into account the profile of the blast cleaned substrate. One widely used method to compensate for this is first to obtain an average of the peak-to-trough height of the surface after surface preparation and before coating, and then subtract this value from the reading shown on the display of the gauge. Other methods

require the use of smooth surface shims that are coated at the same time as the work piece. No surface profile then needs to be deducted.

It can be seen that it is essential that the specification makes clear what is required and how fulfilment of the requirement should be ascertained. In situations where the specification is lacking in these respects, it is important that agreement as to what the actual requirements are and how they are to be monitored is resolved prior to project commencement.

A significant number of measurements are required to determine whether the target thickness has been achieved. To avoid erroneous readings, measurements should not be taken within 12 mm of edges or holes etc.

As well as measuring the dft, the inspector should check that excessive film thickness is not applied. The 'over application' of paints can result in the formation of high stresses and may cause premature failure of the system.

### Other checks on paint coatings

The requirement for testing of high build glass flake epoxy/polyester paint coatings to check for pinholes or discontinuities has recently been introduced by the Highways Agency as part of a (draft) item sheet for glass flake and polyester in all steel structures. This is to ensure that a satisfactory continuous cover has been achieved.

It should be noted that the test parameters selected for the high voltage holiday testing must take into consideration the coating dielectric strength as well as the coating thickness. Serious damage can be caused to an otherwise sound coating if the coating is subjected to an inappropriate test voltage.

### References

1. Manual of Contract Documents For Highway Works Specification for Highway Works, Series 1900: Protection of Steelwork against Corrosion. 2005.
2. EN ISO/IEC 17024:2003 Conformity Assessment. General requirements for bodies operating certification of persons
3. EN 45020:2007 Standardization and related activities. General vocabulary. (Partially replaced by EN ISO/IEC 17000:2004.)

### Other relevant Standards and further reading

EN ISO 8501-1:2007, Preparation of steel substrates before application of paints and related products. Visual assessment of surface cleanliness. Rust grades and preparation grades of uncoated steel substrates and of steel substrates after overall removal of previous coatings

EN ISO 8503-1:1995, BS 7079-C1:1989. Preparation of steel substrates before application of paints and related products. Surface roughness characteristics of blast-cleaned steel substrates. Specifications and definitions for ISO surface profile comparators for the assessment of abrasive blast-cleaned surfaces.

EN ISO 2808:2001, BS 3900-C5:1997. Paints and varnishes. Determination of film thickness.

Corrosion Protection of Steel Bridges, Corus, 2005.

*Acknowledgement: This Note was prepared with the advice of J.D.Griffiths, Director, Griffiths and Associates Ltd. Consulting and Inspecting Protective Treatment Engineers.*

