

SCI PUBLICATION 172

Castings in Construction

Nancy R Baddoo MA, CEng, MICE

Published by:

**The Steel Construction Institute
Silwood Park, Ascot
Berkshire SL5 7QN**

**Telephone: 01344 23345
Fax: 01344 22944**

© 1996 The Steel Construction Institute

Apart from any fair dealing for the purposes of research or private study or criticism or review, as permitted under the Copyright Designs and Patents Act, 1988, this publication may not be reproduced, stored, or transmitted, in any form or by any means, without the prior permission in writing of the publishers, or in the case of reprographic reproduction only in accordance with the terms of the licences issued by the UK Copyright Licensing Agency, or in accordance with the terms of licences issued by the appropriate Reproduction Rights Organisation outside the UK.

Enquiries concerning reproduction outside the terms stated here should be sent to the publishers, The Steel Construction Institute, at the address given on the title page.

Although care has been taken to ensure, to the best of our knowledge, that all data and information contained herein are accurate to the extent that they relate to either matters of fact or accepted practice or matters of opinion at the time of publication, The Steel Construction Institute, the authors and the reviewers assume no responsibility for any errors in or misinterpretations of such data and/or information or any loss or damage arising from or related to their use.

Publications supplied to the Members of the Institute at a discount are not for resale by them.

Publication Number: SCI-P-172

ISBN 1 85942 041 9

British Library Cataloguing-in-Publication Data.

A catalogue record for this book is available from the British Library.

FOREWORD

Casting is a versatile method of producing structural iron and steel components of complex shape, or of shapes that would be difficult to fabricate from wrought steel. This publication provides advice for structural engineers, architects and fabricators on the selection, design and procurement of castings.

The preparation of this guide was sponsored by the following organisations:

Department of Trade and Industry
British Steel Tubes & Pipes
Goodwin Steel Castings Ltd

The publication has been prepared by The Steel Construction Institute under the guidance of a project advisory group including representatives from the sponsoring organisations and other recognised experts. Their contribution to the preparation of the guide is gratefully acknowledged. The group consisted of the following people:

Martin Manning (<i>Chairman</i>)	Ove Arup & Partners
Steven Birks	Goodwin Steel Castings Ltd
Brian Goodall	British Steel Tubes & Pipes
Alan Jones	Anthony Hunt Associates
Keith Temple	Westbury Tubular Structures plc
Bassam Burgan	The Steel Construction Institute

The publication was also reviewed by Cast Metals Development and Arup Research and Development.

CONTENTS

	Page No.
SUMMARY	vi
1 INTRODUCTION	1
1.1 What is a casting?	1
1.2 Why use castings in structures?	1
1.3 What has prevented the wider use of castings in structures?	4
1.4 A brief comparison of wrought, forged and cast metals	5
1.5 Objectives of this design guide	6
2 CASTING MANUFACTURE	8
2.1 The casting process	8
2.2 Patterns	8
2.3 Moulds	10
2.4 Feeding and gating	13
2.5 Finishing of castings	14
2.6 Technological advances in casting manufacture	15
3 DESIGN CONSIDERATIONS	17
3.1 Material selection	17
3.2 Designing for production - limitations on section size, shape and thickness	22
3.3 Prototyping	26
3.4 Costs	27
4 DETAILED DESIGN	29
4.1 Structural analysis	29
4.2 Structural design	29
4.3 Welding	30
4.4 Machining	32
4.5 Dimensional tolerances	32
4.6 Surface finish	34
4.7 Surface treatment	35
5 INSPECTION AND TESTING	37
5.1 Verification of mechanical properties	37
5.2 Non-destructive testing - an introduction to the main methods	38
5.3 Non-destructive testing - guidance on typical specification requirements and acceptance levels	41
5.4 Repair	45

6	PROCUREMENT	46
6.1	Procurement route	46
6.2	Procurement specification	47
6.3	Castings for standardised simple connections	47
7	REFERENCES	52
APPENDIX A	Mechanical and physical properties	54
APPENDIX B	Key issues which require addressing in a specification for a cast structural component	58
APPENDIX C	Detailed case histories	64
APPENDIX D	Summary of recent projects using castings	78
APPENDIX E	Specifications and Standards relating to castings	82
APPENDIX F	Useful addresses	84
APPENDIX G	Addresses of some UK foundries supplying structural castings to the construction industry	85
	Photographic credits	87

SUMMARY

The purpose of this guide is to advise structural engineers, architects and fabricators of the properties and capabilities of iron, carbon steel and stainless steel castings. It emphasises that the high strength, ductility and toughness of these castings, coupled with their efficient production method, offer cost-effective solutions for a variety of structural components. Additionally, castings have excellent surface finish, together with good welding and machining characteristics. Functional shapes can be streamlined to give the best combination of strength, stiffness, slenderness and weight, thus saving on materials and minimising manufacturing costs.

The guide explains the basic processes and techniques of casting and provides information for the designer on welding, surface finishes, tolerances and inspection and testing methods. The guide emphasises that the specification of the correct casting techniques and the appropriate level of quality are very important and require close liaison between the foundry and the design and construction team. The procurement process is explained and illustrated with flowcharts.

Appendices give examples of recent projects using structural castings, including four detailed case histories featuring main truss connections, glazing connections, beam to column connections and compression members in a bridge. Lists of sources of further information and the addresses of some UK foundries are also given.

Pièces moulées pour la construction

Résumé

Le but de ce guide est d'informer les ingénieurs, architectes et constructeurs sur les propriétés et les possibilités du moulage de pièces en fer, en acier au carbone, ou en acier inoxydable. Il montre que la grande résistance, la ductilité et la dureté de ces pièces moulées, associées à des méthodes de production très performantes, peuvent apporter des solutions intéressantes pour une grande variété de composants structuraux. En plus, les pièces moulées ont un excellent fini de surface, une bonne soudabilité et sont aisées à retravailler à l'aide de machines outils. La forme des pièces peut être optimisée pour obtenir la meilleure combinaison possible de résistance, rigidité, élancement et poids propre, permettant ainsi d'économiser la matière et de minimiser le coût de fabrication.

Le guide explique les procédés et techniques de moulage et fournit les informations principales relatives au soudage, au fini de surface, aux tolérances et contrôles ainsi qu'aux méthodes d'essais de pièces moulées. Il insiste sur l'importance d'une bonne collaboration entre la fonderie, le projeteur et le constructeur et donne des informations concernant les spécifications à préciser.

Des annexes donnent des exemples de réalisations récentes concernant des assemblages de charpentes métalliques, des assemblages pour verres structuraux, des assemblages poutres-poteaux et des éléments comprimés de ponts. Une liste de références, d'adresses utiles et de fonderies anglaises est également fournie.

Gußteile im Bauwesen

Zusammenfassung

Der Zweck dieses Leitfadens ist die Beratung von Tragwerks-planern, Architekten und Stahlbauern bezüglich Eigenschaften und Fähigkeiten von Gußteilen aus Eisen, Stahl und rostfreiem Stahl. Hohe Festigkeit, Duktilität und Härte, verbunden mit effizienten Herstellungsmethoden führen zu wirtschaftlichen Lösungen für eine Vielzahl von Bauteilen. Gußteile können eine hervorragende Oberfläche haben und gut schweiß- und bearbeitbar sein. Die Formen können so gestaltet werden, daß eine bestmögliche Kombination von Festigkeit, Steifigkeit, Schlankheit und Gewicht, Einsparungen bei Material und Fertigungskosten ermöglicht.

Der Leitfaden erklärt die grundlegenden Prozesse und Techniken beim Gießen und informiert über Schweißen, Oberflächenbeschaffenheit, Toleranzen und Prüfmethoden. Betont wird, daß die Auswahl des richtigen Gießverfahrens und das erforderliche Qualitätsniveau sehr wichtig sind und eine enge Zusammenarbeit zwischen Gießerei, Entwurfs- und Montageteam erfordern. Der Beschaffungsprozeß wird erklärt und mittels Flußdiagrammen illustriert.

Im Anhang sind ausgeführte Projekte zu finden, die vier detaillierte Fallbeispiele enthalten (Fachwerkknoten, Verbindungen für Verglasungen, Träger-Stützen-Verbindungen, druckbeanspruchte Bauteile in Bücken). Weitere Informationsquellen und die Adressen einiger englischer Gießereien sind ebenfalls angegeben.

Elementi da fusione per le costruzioni

Sommario

Questo manuale intende illustrare a ingegneri strutturisti, architetti, e produttori le proprietà e le potenzialità di elementi ottenuti da fusione in ferro, in acciaio al carbonio e in acciaio inossidabile. Si sottolinea come l'alta resistenza, la duttilità e la tenacità degli elementi fusi, soprattutto se accoppiate a un efficiente metodo di produzione, offrano soluzioni altamente competitive anche dal punto di vista economico per una vasta gamma di elementi strutturali. In aggiunta, i prodotti ottenuti per fusione presentano un'eccellente rifinitura superficiale unitamente a un'ottima saldabilità e una buona lavorabilità. I profili possono essere progettati in modo da fornire la migliore combinazione di resistenza, rigidità, snellezza e peso al fine di risparmiare materiale e quindi minimizzare i costi di produzione.

Il manuale illustra i principali processi e le tecniche di fusione e fornisce al progettista informazioni relative alla saldabilità, alla rifinitura superficiale, alle tolleranze, ai controlli e ai metodi di prova. Inoltre viene sottolineato come la precisazione della corretta tecnica di fusione unitamente a un adeguato livello di qualità risultano fattori molto importanti e richiedono una stretta collaborazione tra i gruppi di lavoro di fonderia, di progettazione e di costruzione. Il processo produttivo viene spiegato e illustrato con dettagliati diagrammi di flusso.

Nell'appendice sono presentati alcuni esempi relativi a recenti progetti realizzati con elementi fusi; sono trattate in dettaglio quattro problematiche relative a collegamenti in sistemi reticolari, collegamenti per vetrate, collegamenti trave-colonna e elementi compressi per strutture da ponte. Infine è fornito un elenco di riferimenti per ulteriori informazioni unitamente agli indirizzi di alcune fonderie della Gran Bretagna.

Los moldeados en la construcción

Resumen

El objetivo de esta guía es ayudar a los ingenieros estructuralistas, arquitectos y talleres, a comprender las propiedades y posibilidades de los moldeados de hierro, aceros al carbono y aceros inoxidable. Se hace hincapié en la alta resistencia, ductilidad y tenacidad de estos moldeados lo que combinado con su eficiente método de producción ofrece soluciones competitivas en coste para diferentes tipos de componentes estructurales. Además los moldeados tienen un excelente acabado superficial junto con buenas propiedades de soldabilidad y mecanizado. Puesto que las formas pueden proyectarse para conseguir la mejor combinación de resistencia, rigidez, esbeltez y peso, es posible conseguir la reducción del material empleado así como minimizar los costes de fabricación.

La guía explica los procesos fundamentales y las técnicas de moldeo además de suministrar información para el proyectista sobre la soldabilidad, acabados superficiales, tolerancias y métodos de inspección y ensayos. La guía acentúa la importancia de las especificaciones para conseguir técnicas correctas de moldeo y niveles de calidad apropiados entre la fundición y los equipos de proyecto y construcción. El proceso de adquisición es explicado e ilustrado mediante flujogramas.

En los apéndices se dan ejemplos de proyectos recientes que usan modelos estructurales, entre los que se incluyen cuatro casos detallados que sirven de ejemplo a uniones de cerchas maestras, uniones en vidrieras, uniones viga columna y piezas comprimidas de puentes. Además se incluyen listas de fuentes documentales para mayor información y direcciones de algunas fundiciones en el Reino Unido.

Gjutna byggkonstruktioner i stål

Sammanfattning

Syftet med denna handbok är att upplysa konstruktörer, arkitekter och stålbyggare om egenskaper och användbarheten av gjutna konstruktioner i järn, stål och rostfritt stål. Den betonar att den höga hållfastheten, formbarheten och hårdheten hos de gjutna konstruktionerna, tillsammans med den effektiva produktionsmetoden erbjuder kostnadseffektiva lösningar på en rad olika konstruktionskomponenter. Dessutom har gjutna konstruktioner en utmärkt ytfinish samt goda svets-och mekaniska egenskaper. Konstruktioner kan utformas så att man får den bästa kombinationen av styrka, styvhet, slankhet och vikt så att material sparas och tillverkningskostnaderna minimeras.

Handboken förklarar grundläggande om processer och teknik vid gjutning samt ger information till konstruktörer om svetsning, ytfinish, toleranser och kontrollmetoder. Handboken betonar att noggrann specifikation av rätt gjutteknik och rätt kvalitetsnivå är väldigt viktig och kräver samordning mellan gjuteriet, konstruktör och byggare. Processen för att ta fram en gjuten byggkomponent är förklarad och illustrerad med flödesscheman.

I appendix ges exempel på genomförda projekt där man använt sig av gjutna konstruktionsdetaljer inklusive fyra detaljerade beskrivningar av anslutningar i fackverk och glasade konstruktioner, balk-pelareanslutning samt tryckta komponenter i en brokonstruktion. Litteraturhänvisningar och adresser till gjuterier i Storbritannien avslutar handboken.

1 INTRODUCTION

1.1 What is a casting?

Iron and steel castings are formed by pouring molten metal into a mould containing a cavity which has the desired shape of the component. The liquid metal cools and solidifies in the mould cavity and is then removed for cleaning. Heat treating may be required to meet desired properties, but there is no need for subsequent hot or cold working. Casting is a versatile method of metal processing because it provides a direct means of manufacturing complex shapes. Castings can be produced as one-off components or in many thousands.

Castings can be produced in a wide range of sizes and weights, the upper limits being governed by:

- the casting process used,
- the required mechanical properties,
- the required surface finish.

It is possible to achieve high strength, high ductility and high toughness in the cast form. Castings can have excellent surface finish and good welding and machining characteristics.

Castings can operate at high and low temperatures, under high pressure and in severe environments. They do not exhibit the effects of directionality on mechanical properties that exist in some wrought steels.

1.2 Why use castings in structures?

In building structures, castings have been used as compression members (*e.g.* columns, brackets, *etc.*) for 200 years. However, in the last twenty years or so, the desirable combination of high strength, ductility and toughness coupled with an efficient manufacturing route has led to increasingly diverse applications as structural components for use in both offshore and onshore construction. For example, castings have been used in offshore platforms for fatigue resistant nodes, heavy duty lifting padears, conductor guides, and nodes for modules and module support frames. Onshore, castings have found applications as glazing connections, beam to column connections, as compression members in bridges as well as major cable saddles in suspension bridges.

Some advantages of using castings are:

Unlimited choice and range of sizes and sections - from simple block or plate-like structures to highly intricate forms.

Streamlined shapes for minimum stress concentration - Notches, abrupt changes in section, and sharp fillets can lead to premature failure of parts subject to fatigue loads. Castings permit the use of shaped fillets and blended sections at any location

including highly stressed areas. Streamlined designs which minimise stress concentration in service also tend to be best from the standpoint of castability.

Shaping for maximum strength and minimum weight - metal can be added where it is needed for greatest resistance to bending, compression and tension forces.

Single integral components - single piece construction leads to greater structural rigidity and avoidance of misalignments and assembly errors.

High dimensional accuracy - tight tolerances can be achieved depending on service requirements, pattern equipment, size of casting, process employed and finishing requirements.

Desirable surface finish - a wide range of surface finishes can be achieved, depending on the casting process employed. It is easier to achieve a consistently higher standard of surface finish with a casting than with a fabrication.

Ease of integration within the overall structure - a cast connection is formed off-site, within a quality controlled foundry environment and facilitates simple site assembly. With a casting it is possible to displace welded joints to locations of reduced stress, usually where welding can be carried out more easily. Use of a fully tested component can lead to easier post-assembly inspection.

With these advantages in mind, it can be seen that a casting may be a cost-effective design solution for:

- large quantities of repetitive components,
- complicated tubular connections, with incoming members at different angles,
- connections subject to very high forces, where large welds would be difficult to inspect and test and expensive to repair,
- tapered sections, or where thick sections are required adjacent to thin sections,
- thick plate details where isotropic material properties are required,
- visibly exposed connections where aesthetics are important,
- fatigue-sensitive joints.

Table 1.1 on page 4 summarises the reasons for choosing a casting, giving examples of recent projects (some of which are described later in this publication) and Figure 1.1 gives a schematic cost comparison between cast and fabricated components.

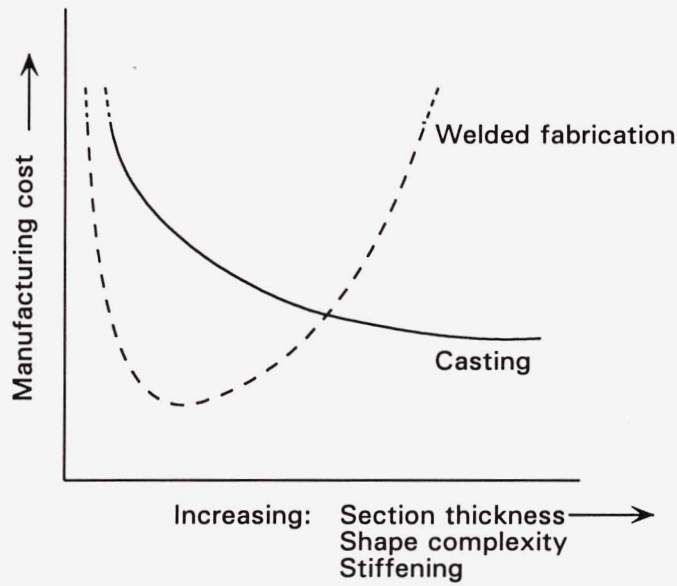

Figure 1.1 *Schematic cost comparison between cast and fabricated components*

(Steel Castings Handbook, 6th Ed., Steel Founders' Society of America and ASM International, 1995)

Figure 1.2 shows the cast steel fork-ends used to form the connections between the principal tubular members in the Clydebank Tourist Village. The fork-ends were cast with a spigot and shoulder to suit the internal and external diameters of the tubes, which were cut square to length and butt welded to the castings.

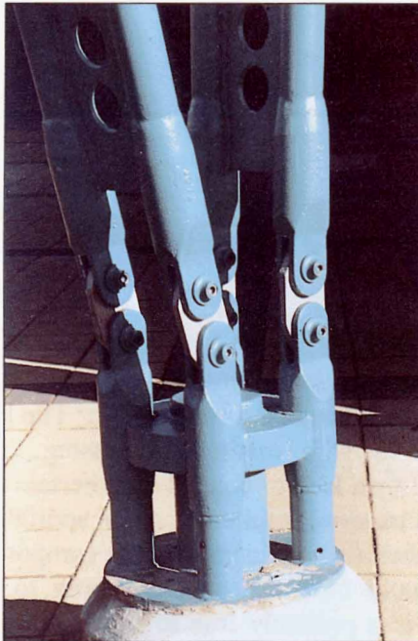

Figure 1.2 *Cast fork-end connectors in the Clydebank Tourist Village*

Table 1.1 *Why choose a casting?*

	Reasons	Examples
Fabrication reasons	<p>Component is difficult to fabricate</p> <p>Not possible to fabricate the component in such a way that it can be tested after assembly</p>	<p>Main truss pin connections at Waterloo International Terminal Trainshed Roof</p> <p>Circular infill member in Tees Barrage bridge</p>
Post-fabrication reasons	<p>Requires unreasonable amount of non-destructive testing</p> <p>Fatigue-sensitive areas of peak stress even after stress-relieving</p>	Nodes in Lee House
Commercial reasons	<p>Cheaper</p> <p>Quicker</p>	<p>Bracing fork ends at NEC</p> <p>Tubular node joints at Stansted Airport</p>
Visual requirements	<p>Finish</p> <p>Shape</p> <p>Uniformity</p> <p>Lack of welds</p>	<p>Beam to column nodes at Bedfont Lakes</p> <p>Main node joints at Ponds Forge swimming pool</p> <p>Glazing arms at Western Morning News</p>
Miscellaneous	<p>Desire to have component made in one piece</p> <p>Integrating a whole number of different elements</p>	Stainless steel glazing fixings

1.3 What has prevented the wider use of castings in structures?

Structural castings are not widely used. This is partly due to the lack of easily available technical data and information on the cast material, along with concerns about the presence of defects, brittleness and weldability. The latter concerns date back to problems encountered with castings possessing inferior mechanical properties which were caused by a lack of control over certain foundry processes. Providing the correct grade of material is selected and an appropriate inspection and testing regime implemented, there is no reason why the composition, properties or performance of castings should be inferior in any way to that of fabricated components. Nevertheless, it is probably true to say that the total value of the castings in the structure usually needs to be high to justify the design and verification time needed.

Tight project schedules have also acted as a disincentive to pursue a cast solution partly because of the 'novelty' factor and also the increased risks of delay arising from sub-contracting part of the steelwork contract to a foundry. Foundries should be aware of this concern, and it is the responsibility of the fabricator to ensure that the founder fully appreciates the implications of the construction programme.

A further objection to the use of castings has been their high cost, but experience shows that this has frequently been due to over-specification, again arising from the paucity of design data available to structural engineers and architects, and ignorance of the capabilities of the modern casting processes.

1.4 A brief comparison of wrought, forged and cast metals

Wrought metal is metal that has undergone hot rolling. Slabs, billets or blooms (semi-finished cast products of the iron or steel making processes) are reheated, then passed through a series of mills and rolls of the required profile to force the hot metal into the finished shape. Most steel products have undergone hot rolling.

A forging is manufactured by heating a bloom to the austenitising temperature range and then forming it by repeated mechanical pressing in different directions to achieve the required shape. Simple shapes with high volume requirements are suitable for forging.

The mechanical properties achievable with castings, particularly cast steels, are generally comparable with those of hot rolled structural steels. Similarly, the quality, integrity and consistency of castings are at least as good as for fabricated steel.

Many of the material compositions used for castings are quite similar to those of standard wrought metals. However, the mechanical properties of cast metals are not necessarily identical to those of wrought metals of corresponding composition, because castings do not receive the benefits of hot working. The properties such as yield stress and ductility of wrought metals are related to the thickness of the material, whereas those of cast metal are less thickness-dependent. The mechanical properties of castings quoted in British Standards are those determined either from separately cast or attached test bars. Close liaison is therefore required between the structural engineer and foundry to ensure that the desired properties are achievable for the section size under consideration, and not just the test bar (see Section 5.1).

It is possible to obtain cast steels with similar strength and ductility to wrought steels. The longitudinal (*i.e.* parallel to the main rolling direction) properties of a wrought or forged steel are somewhat higher than the properties of a cast steel of similar composition. However, the transverse properties are lower by an amount that depends on the degree of working. (Specifications for wrought steels are based on test results for properties parallel to the main rolling direction.)

Structural cast steels can be obtained with equivalent strength and toughness to grade S355J2 to BS EN 10025 (formerly 50D to BS 4360) steel. Table 3.1 in

Section 3.1.4 compares the mechanical properties of two cast grades of carbon steel with those of the hot rolled grades S275 and S355.

Cast steels are no more difficult to weld than wrought steels.

The cross-section of a casting can be chosen with the design loads in mind to give optimum strength and stiffness properties. Design with rolled sections is limited by the available standard sizes. Forged components offer greater design flexibility than wrought products. Compared to castings, however, their design flexibility is limited due to manufacturing considerations (die design) and the high cost of design changes (new dies required).

1.5 Objectives of this design guide

The purpose of this guide is to give structural engineers, architects and fabricators the information they need in order to:

- assess whether casting is the most appropriate production method for a given component,
- understand the underlying principles of designing a casting, including the limitations and capabilities of different casting techniques,
- specify adequate but realistic requirements concerning material, surface finishes, tolerances, inspection and testing,
- understand the process for procuring a structural casting,
- assess the impact of using a casting on the project schedule.

Section 2 describes the casting production process.

Section 3 covers fundamental design considerations related to production, material selection and costs. Further details on mechanical properties are given in *Appendix A*.

Section 4 deals with detailed design issues such as structural design, welding, surface finishes and tolerances.

Section 5 discusses inspection, testing and repair methods.

Section 6 covers the procurement process for castings, advising on project scheduling and the preparation of a casting specification. *Appendix B* discusses the minimum issues which need to be addressed in a casting specification.

Section 7 gives details of publications which are referred to in the main text. Published Standards are not individually referenced; a list of relevant Standards is given separately in *Appendix E*.

Appendix C gives four detailed case histories of projects using iron, steel and stainless steel castings, outlining the reasons for using a casting in each case, any particular problems encountered and how they were overcome.

Appendix D gives a list of recent construction projects using structural castings.

Appendix F gives some useful addresses for obtaining further information on castings.

Appendix G gives the addresses of some foundries in the UK and the types of castings they produce. The foundries listed here all have some experience of producing structural castings for the construction industry.

The guide recognises that a structural engineer need not be an expert on all the various issues arising out of the use of castings. Rather, he or she will have to seek advice from independent specialists and/or the foundry. The extent of this advice will, of course, depend on the importance of the cast component within the overall structure.

There is a danger of the foundry assuming that the engineer is in control technically, while the engineer assumes the foundry is in control! For example, if surface finish requirements or dimensional tolerances are not defined in detail in the specification, then the foundry will supply castings which meet a low standard of surface finish and wide dimensional tolerances. Some foundries are used to dealing with expert clients and may not question what they are asked to do. However, the engineer may be expecting the foundry to advise when something could be changed to improve the finish or tolerance, or to reduce costs.

Certain aspects of casting design and production will differ depending on the significance of the role played by the casting within the overall structure. Furthermore, the size and shape of some castings are controlled by aesthetic rather than functional requirements. As a consequence, such castings may only be subject to low stresses in service. The guide highlights instances where these castings merit different treatment from those subject to stress levels more typical of structural components.

This guide is written primarily with castings for building and bridge structures in mind. However, the basic principles also apply to castings in offshore structures, although higher strength and tougher grades are usually required, and fatigue resistance is then a key design criterion.

2 CASTING MANUFACTURE

This Section gives a brief introduction to methods of casting manufacture. Castings must be designed both with production and performance in mind, so early collaboration between structural engineer, fabricator and founder is essential. It is also important for the architect, engineer and fabricator to understand the method of casting production so they are aware of any problems that the founder may have to overcome and the kinds of shape which may be difficult to form.

The founder will be able to advise on the type of pattern and the method of moulding required to produce a casting of the desired surface finish and dimensional accuracy. The method of casting manufacture has a major impact on the delivery time and cost.

2.1 The casting process

A casting is formed by pouring molten metal into the cavity of a mould which is the exact shape of the casting to be produced.

Moulds are formed by packing a refractory material, usually sand containing a suitable bonding agent, firmly around a pattern of the shape to be cast. The pattern and compacted sand are usually contained in a moulding box assembly. The most suitable method of moulding depends on the size of the cast product, the number required, the desired surface finish, *etc.*

After compaction, the pattern is removed and metal is poured into the mould cavity through channels which form the runner system. Where internal cavities are required in the casting, these are formed by inserting appropriately shaped sand plugs called cores. They are located in the mould cavity by means of projections called prints which are generally at the ends of the cores.

Once the metal has completely solidified, the casting is taken out of the mould and finished by removing excess metal and blemishes.

Figure 2.1 shows a simplified flow diagram of the basic operations for producing a casting.

2.2 Patterns

Patterns are usually made of wood, but metal or plastic may be used when long production runs are envisaged. Patterns are generally split, with the two halves mounted on separate plates or boards, one forming the top and one the bottom of the mould. The parting line is the plane or planes along which a pattern is split. Parting in one plane facilitates the production of the pattern as well as the making of the mould.

Patterns are not a simple positive of the casting, but allow for the flow of molten metal as well as its contraction during cooling and solidification.

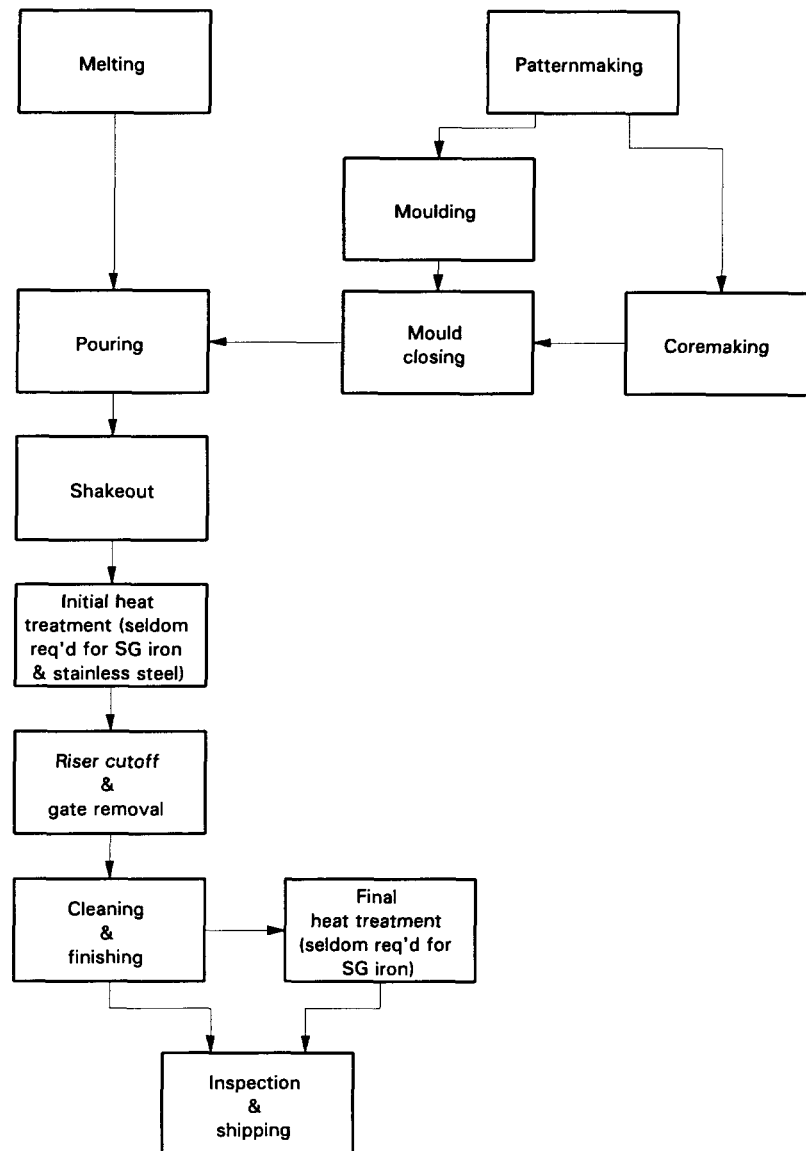

Figure 2.1 *Flow diagram of the basic operations for producing a casting*
(Adapted from Steel Castings Handbook, 6th Ed., Steel Founders' Society of America and ASM International, 1995)

Extra feed metal must be placed at strategic locations around the mould during casting to avoid the formation of unwanted cavities within the casting due to shrinkage on solidification. The overall aim is for all parts of the casting to cool and solidify at approximately the same rate. Patterns should be made with dimensions larger than those required in the finished casting. Typical shrinkage allowances are 0-0.7% for SG iron, 2% for carbon steel and 2.5% for stainless steel.

The vertical sides of a pattern usually have a taper or draft to permit removal of the pattern from the mould. Some patterns include projections called core prints to hold cores for producing shapes such as internal cavities which cannot be moulded directly from the pattern. To ensure adequate dimensional accuracy of the cast product, the probable wear rate of the pattern must also be considered.

The choice and design of pattern depends on the number of castings to be produced, the moulding and core process to be used, dimensional tolerances required and size and shape of casting. Investing in a good pattern can lead to considerable cost savings in the long term, *e.g.* by reducing the cost of machining the cast product.

For replacement work, it may be possible to use an original casting as the pattern, although the new piece will be slightly smaller than the original due to shrinkage. This is only likely to be practical if one or a small number of castings are needed and the piece required is reasonably small. With large pieces, a replica may be made by forming a mould of plaster of Paris or latex against the original and then casting a pattern inside this in epoxy resin.

2.3 Moulds

The prime requirement of a mould is that it must be able to withstand the action of the poured metal and extract heat from the molten metal in such a way as to produce the required mechanical properties in the casting.

No single moulding process will satisfactorily make all types and sizes of castings. Therefore the process must be carefully selected in order to produce castings which are 'fit-for-purpose', to specified dimensional tolerances and with the desired surface finish. Table 2.1 compares the relative cost, dimensional accuracy, flexibility, *etc.* of the main sand casting techniques.

2.3.1 Sand moulding processes

The principal sand mould production techniques are briefly described below.

Greensand moulding

Most iron and steel castings weighing up to 200 kg are produced in greensand moulds in which the sand grains are bonded together by a moist clay film. The metal is poured into the mould with the sand in its green or undried state.

Drysand moulding

This is a similar process to greensand moulding except that the clay-bonded sand is dried before pouring, which increases its strength. These moulds are therefore suitable for heavier castings requiring more rigid moulds. Because the drying process is slow and highly skilled labour is required, drysand moulds are rarely used, and have been superseded by cold-set moulding techniques which enable rigid moulds to be produced more quickly.

CO₂/silicate process for bonding moulds

A binder based on a solution of sodium silicate is mixed with silica sand which is then easily compacted to form a mould. The mould is hardened by passing CO₂ gas through the mould material for a short period (usually seconds). The mould rapidly develops moderate strength, and upon standing very high strengths can be achieved. Castings made from this process are dimensionally accurate, have a good surface finish and are less likely to suffer from porosity and blow-hole defects. Gas hardening is less suitable where large masses of sand are involved and so cold-set sands are preferable for medium to large moulds.

Table 2.1 *A comparison of the main sand moulding processes (approximate and depending upon the alloy to be cast)*

(Adapted from Kempe's Engineer's Yearbook, 97th Ed., Benn Business Information Services Limited, 1992)

Moulding process	Casting weight	Number of Castings		Types of pattern	Relative cost		Dimensional accuracy (casting)	Surface finish (casting)	Relative ease of changing design in production
		min.	max.		in small numbers	in quantity			
Greensand	0.025kg to 1 tonne	1	Limited to pattern life	Wood Resin Metal	Low	Lowest	Poor to very good	Poor to very good	Poor to good
CO ₂ process	0.025kg to 20 tonne	1	Limited to pattern life	Wood Resin	High	Low	Good	Good	Very good
Cold-set sands	0.025kg to 200 tonne	1	Limited to pattern life	Wood Resin	High	Low	Good to very good	Very good	Very good
Shell moulding	0.025kg to 100kg	500	Limited to pattern life	Metal	Highest	Low	Excellent	Excellent	Very good
Expendable pattern (a) Bonded sand	20kg to 20 tonne	1	5	Polystyrene	Lowest	Very high	Poor to good	Poor to good	Excellent
(b) Unbonded sand (vacuum)	1kg to 250kg	500	20,000 +	Polystyrene	Very high	Low	Very good	Very good	Very poor

Cold-set sand moulding

Cold-set sands include a hardening agent (usually a resin) which causes them to set in a predictable manner at room temperature, the speed being determined by the amount or strength of hardener that is added. Accurate casting dimensions are obtained and casting surface quality is excellent. The process is very flexible and is used for producing castings in all metals weighing from a few kilograms up to 200 tonnes.

Shell moulding

In this process, a heated metal pattern is covered with a layer of sand whose grains have been pre-coated with resin. Heat conduction from the pattern cures the resin to a limited depth, resulting in the production of a relatively thin-wall mould. This process is particularly suited to the production of large numbers of small to medium-sized castings with good surface finish and dimensional accuracy.

Expendable pattern moulding

Expendable polystyrene patterns are used to a limited extent, particularly for the production of one-off or restricted quantity designs. The pattern can be constructed at low cost by gluing together sections cut from expanded polystyrene slabs. Because of the low density of this material, the pattern need not be removed from the mould. When the casting is poured, the products of decomposition of the pattern escape by diffusion through the mould and core venting system. As the pattern is not removed from the mould, there are no parting lines, no pattern taper and the use of separate cores is not required. Cold-setting sands are often used for the production of castings in small batches by hand moulding. For repetitive work the 'Replicast' method may be used where unbonded sand is held by an applied vacuum.

2.3.2 Cores and core-making

Cores are separate shapes which are placed in the mould to provide castings with contours, cavities and passages which cannot be provided by the mould. The shapes of cores are often complex. Some provision must be made in the design of the mould for supporting the core. Most of the principles that apply to making a mould are relevant to cores also. In addition, they must be sufficiently low in gas-forming materials to prevent excess gas entering the metal, and are more likely to be subjected to severe temperature conditions whilst retaining their shape until they are required to collapse at a critical stage of solidification.

2.3.3 Special moulding and casting processes

Investment casting or lost wax process

A mould is produced by coating (investing) a wax replica of the final casting with a refractory slurry that sets at room temperature. The wax is then melted or burned out leaving a cavity in the mould of exactly the same shape as the wax pattern. This process is suitable for certain highly specialised castings, requiring an unusually fine finish, precise detail or close tolerances. It is generally limited to the mass production of small castings with weights from 0.025 kg to about 10 kg and with section thicknesses in the range of 1-2 mm to about 75 mm.

Ceramic moulding

Ceramic moulds are produced using refractory aggregates bonded with silica. The moulding slurry is poured over the pattern and then allowed to set or gel. The rubbery nature of the gelled mould allows the pattern to be removed without mould distortion. Once the pattern is removed, the mould is torched and fired until it is strong. Casting quality generally lies between that obtained by investment casting and sand casting. Castings have excellent surface finish, close dimensional tolerances and fine details. This process is suitable for castings from 0.025 kg to about 150 kg in weight and with section thicknesses in the range of 1-2 mm to about 75 mm.

Centrifugal casting

In this process metal is poured into a rotating metal mould. It is used for the manufacture of tubular shapes such as pipes and cylinder liners.

Continuous casting

This is a steel-making process whereby solidification takes place within a cooled die from which the solidified product is continuously withdrawn. This process is used for the production of round bar and many other axisymmetric solid sections.

2.4 Feeding and gating

Feeding is the process of supplying molten metal to compensate for volume shrinkage while a casting is solidifying. A riser is a reservoir of molten metal from which a casting feeds as it shrinks during solidification. A gating (or running) system consists of runners (channels) and gates in a mould through which the molten metal flows before entering the casting cavity. Channels are also required to allow gas to escape. In order to obtain a sound casting without shrinkage cavities, it is desirable that sections remote from the feeder head solidify first and those nearest last. This is called directional solidification and can only occur if the gating system is designed correctly to:

- trap slag in the metal or any oxidation products in the runners so that only clean metal enters the mould,
- allow the metal to flow quickly but without turbulence,
- permit the distribution of metal to form a sound casting,
- prevent undue wear or corrosion of the mould or cores.

As liquid and solidification contraction occurs, the formation of shrinkage cavities is prevented by the addition of molten metal from feeder heads. A feeder head needs to be large enough to supply the metal which must remain molten until the casting has solidified.

2.5 Finishing of castings

Once a casting has been separated and removed from its moulds and boxes (this process is called shakeout), it must undergo certain finishing processes. The type, number and sequence depends on the composition and quality requirements of the castings and the manufacture route. Finishing costs can constitute up to 30% of the total process costs for iron and steel castings.

Finishing (also called fettling) operations typically involve:

- removal of moulding material and scale (usually by abrasive blast cleaning or chemical cleaning methods such as acid pickling),
- removal of excess metal such as feeder heads, runner systems and any metal which is superfluous to the castings (usually by oxygen/fuel gas cutting, sawing or shearing). This process is called dressing.
- removal of blemishes and defects (usually by welding),
- smoothing over the weldments, areas from which metal has been cut, or any rough areas on the casting surface (generally by grinding). Hand grinding may also be used to improve dimensional accuracy, especially at important points of the casting.
- for steel and stainless steel castings, heat treatment, usually by annealing, normalising or both. Heat treatment will dissipate any residual stresses and break up the dendritic grain structure formed during solidification in order to obtain the required mechanical properties. (SG iron castings are often used 'as-cast'; the required mechanical properties being obtained by compositional control.)

Figure 2.2 shows a casting just after removal from the mould.

Accurate moulds and careful pattern design can help to reduce this labour intensive activity. Sometimes, fettling operations will include machining if the accuracy required in the piece cannot be achieved simply by casting. For example, column bases or other bearing surfaces may need to be machined flat. It may also be necessary to drill holes in the casting: holes are easier to form accurately in this way rather than by casting them.

Finishing operations also involve checking, testing and inspection, and in some cases, polishing, painting, *etc.*

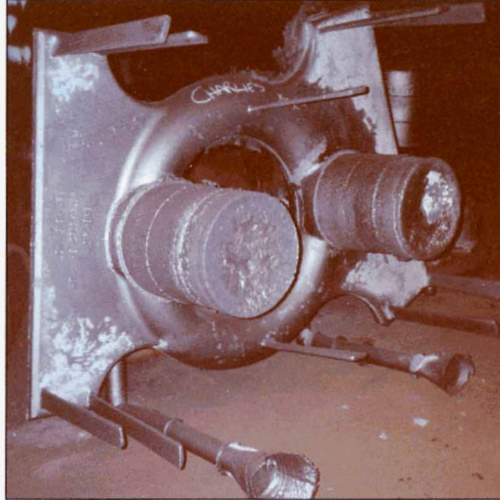

Figure 2.2 *Casting for Tees Barrage Bridge just after it was removed from the mould, with risers and feeder heads still attached*

2.6 Technological advances in casting manufacture

Computer programs are used increasingly in casting production and have enabled costs to be cut and production to be speeded up. Programs to calculate feeder head sizes and casting weights have been used in foundries for many years. Newer programs model solidification of the casting in order to optimise its shape. As well as explaining shrinkage problems, solidification times can be predicted. It is also possible to predict residual stresses, which is useful for alleviating hot cracking. Hence problems can be identified and corrective measures taken prior to production. These models assume that the mould is full; computer simulations of mould filling are still under development.

Figure 2.3 shows the predicted temperature distribution across a section of a steel node during solidification using the software package Magma.

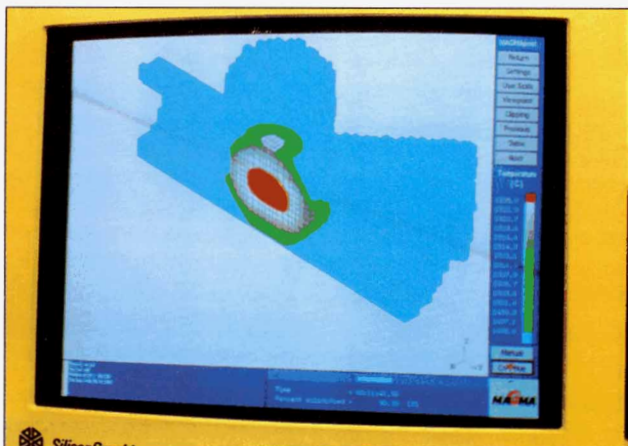

Figure 2.3 *Predicted temperature distribution across a section of a steel node during solidification*

There are also software products available for the generation of machining instructions to produce patterns or other relevant tooling. This enables geometrically accurate patterns and/or prototypes to be manufactured at lower cost and with short lead times. Modifications can also be easily carried out.

3 DESIGN CONSIDERATIONS

3.1 Material selection

A very wide range of iron and steel castings are available with varying mechanical and physical properties, making them suitable for sub-zero, heat- and corrosion-resistant service, wear and abrasion resistance and magnetic or non-magnetic applications.

Although there are British Standards giving physical and mechanical properties of specific grades, in some cases it may be more appropriate for a foundry to develop a new, specific grade exactly suited to a given application. For example, the very large cast steel nodes in Lee House are grade CSN3, which is very similar to grade S355J2 to BS EN 10025 (formerly 50D to BS 4360). This was a grade originally developed for use offshore.

The following sections give some brief information about the metals covered in this guide, namely iron, steel and stainless steel. *Appendix A* gives the mechanical properties of six grades commonly used for structural applications.

3.1.1 Iron

Types of cast iron

Cast iron is an alloy of iron containing more than 2% carbon, 1-3% silicon and up to 1% manganese. Cast iron contains higher levels of trace elements than cast steel. The four most common types of cast iron are briefly described below:

Grey cast iron exhibits non-elastic behaviour under tensile stress, owing to the presence of graphite flakes. It is prone to crack-like discontinuities which reduce the material's tensile characteristics; for this reason it is generally only used in buildings for straightforward compression joints. The tensile strength is typically as low as 20-25% of the compressive strength, depending upon the form of the casting, and the elongation is less than 1% before failure.

White cast iron has a very high compressive strength. It also has a high wear resistance and hardness which are both retained at temperatures up to red heat for limited periods.

Malleable iron is more ductile and has higher strength than grey cast iron. It may be divided into whiteheart, blackheart and pearlitic malleable iron. These are all formed by extended heat treatment.

Spheroidal graphite (SG) iron, also known as *nodular cast iron* or *ductile iron*, is a type of iron developed 50 years ago which displays improved strength and ductility due to the carbon being coagulated into spheres. It is formed by adding magnesium to the melt in the ladle. The tensile strength is typically 75% of its compressive strength, and elongations are between 2 and 22%, depending on the grade. SG iron has found application as standards for crash barriers or bollards because it can be cast to the preferred shape and provides adequate protection against vehicle impact by bending and absorbing energy before breaking.

Generally, the weldability of grey cast, white cast and malleable irons (with the exception of some ferritic grades of malleable iron) is poor, because they are brittle and often cannot withstand contraction stresses set up by a cooling weld. The weldability may be further decreased by hard and brittle microstructures consisting of iron carbides and martensite which form in the heat affected zone.

The type of cast iron used in historical structures was almost always grey cast iron. A number of failures of these structural iron castings occurred in the nineteenth century before the limitations of the material were fully understood (*i.e.* lack of strength in tension and the risk of brittle fracture as a result of notches or cracks in the material). Poor foundry practice also contributed to the failures.

In recent years, cast iron has been making a comeback in conservation work, largely because of the need for castings to replace damaged or lost components. Guidance on appraisal techniques for existing structures and the design of grey cast iron is given by Bussell⁽¹⁾.

The remaining commentary in this publication concerning cast iron is confined to SG iron, since it is the most appropriate type for structural applications due to its improved ductility.

SG iron to BS 2789

The properties of 11 grades of SG iron are given in BS 2789.

The designation system is as follows. The first number of the grade gives the minimum tensile strength in N/mm²; the percentage minimum elongation values are given by the second number of the grade. For example, grade 400/18 has a minimum tensile strength of 400N/mm² and a minimum elongation of 18%.

There are five high-ductility grades of ferritic iron with various combinations of strength and Charpy impact energy. Two of these grades, with L20 and L40 appended to their designation, are grades with high Charpy impact energy at sub-zero temperatures of -20°C and -40°C respectively. Three intermediate-strength grades and three high strength grades which can be either 'pearlitic as-cast and normalised' or 'hardened and tempered' are also given in BS 2789.

The minimum 0.2% proof strengths in tension vary from 215 to 710 N/mm². The modulus of elasticity is around 170,000 N/mm² for all the grades.

Gilbert⁽²⁾ gives further data on the mechanical properties of SG iron to BS 2789.

3.1.2 Carbon steel

Carbon steel has a lower carbon content and thus a higher melting point than cast iron. The tensile and yield strength, ductility, impact properties, fracture toughness, high temperature strength and weldability of cast steel are superior to SG iron. A higher hardness, lower toughness and lower ductility are typically associated with higher strength. Cast steel is usually subjected to heat treatments, consisting of annealing, normalising or annealing and normalising, to produce the necessary property requirements.

Cast steels to BS 3100

The mechanical properties of general engineering cast steels are covered by BS 3100.

The designation system for carbon and alloy steels in this standard consists of one or two letters followed by a number. The first letter is 'A' for carbon and carbon manganese steels and 'B' for low alloy steels. The second letter (if appropriate) consists of one of the following:

No letter	for general purpose use
L	for low temperature toughness
W	for wear resistance
T	with higher tensile strength (low alloy steels only)
M	with specified magnetic properties (carbon steels only)

These letters are followed by an arbitrary reference number.

For example, grade AL2 is a carbon steel casting with specified low temperature toughness properties.

The minimum yield strengths vary from 185 to 695 N/mm². The modulus of elasticity is between 200,000 to 215,000 N/mm² for all the grades.

More information on the properties of steel castings is given in *Steel castings, design properties and applications*⁽³⁾, *Steel Castings Handbook*⁽⁴⁾ and *Kempe's Engineer's Yearbook*⁽⁵⁾.

3.1.3 Stainless steel

The physical and mechanical properties of stainless steels show several important differences from carbon steels. Although density, elastic modulus and specific heat are similar, stainless steels have higher thermal expansion coefficients and lower thermal conductivities than carbon steels. Austenitic stainless steels, which are the types most widely used for structural applications, are non-magnetic and retain a high toughness at very low temperatures.

Cast stainless steels to BS 3100

The mechanical properties of a variety of corrosion and heat resisting cast steels are also covered by BS 3100.

The designation system used is that, wherever possible, the first three digits correspond to the AISI stainless steel designation. The letter 'C' as the fourth character denotes casting and the last two digits are an arbitrary reference number. (The composition of the cast grade differs from that of its wrought equivalent to improve fluidity in the mould, reduce shrinkage and minimize hot tears and cracks.)

Grades 304 and 316 are most suitable for structural applications. 304C15 and 316C16 are the grades with a standard carbon content (0.08%). The low carbon versions 304C12 and 316C12 contain 0.03% carbon and are more appropriate for welding thicker sections (> 15 mm) because of their greater resistance to sensitisation (reduction in corrosion resistance) in weld heat affected zones.

The minimum 1.0% proof strengths vary from 170 to 485 N/mm². The modulus of elasticity is 170 - 200,000 N/mm² for all the grades.

Further information on the mechanical and physical properties of stainless steel castings can be found in references 3, 4 and 5.

3.1.4 Choosing the right material for the job

SG iron has a high carbon content which lowers its melting point and thus eases the casting process. Molten cast iron flows better than cast steel and therefore can form shapes with thinner walls. Iron castings also provide a better surface finish than steel castings. Under conditions of severe abrasive wear where high hardness is required, cast iron may be better than cast steel. In applications where shock or unexpected impact may occur, the superior toughness of steel takes over. Sometimes it is appropriate to use the two materials in conjunction, as in the NODUS joint, which is a standardised jointing system for members in a spaceframe. This joint includes cast SG iron casings and cast steel fork-end connectors (Figure 3.1).

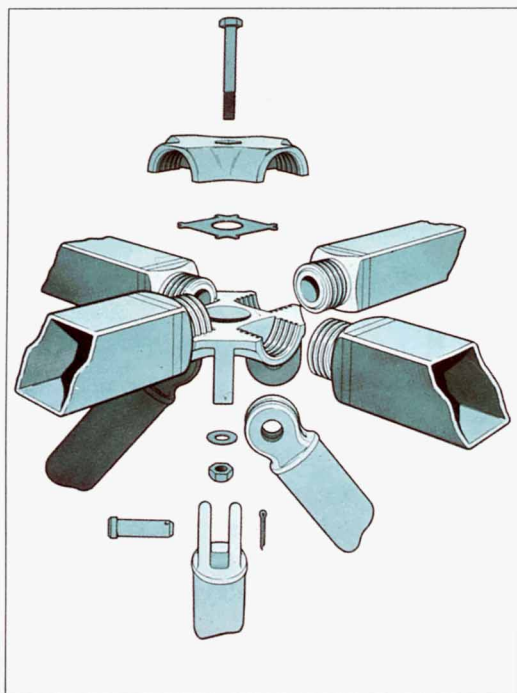

Figure 3.1 *The Nodus joint*

SG iron castings are difficult to weld and are consequently more suitable for bolted connections. For an application where machining presents a major cost element, an SG iron would probably be chosen, provided its toughness was adequate for the intended service.

Stainless steel castings are readily weldable, both to stainless steel and to carbon steel members. Stainless steel castings should be considered where the appearance of the casting is particularly important or if superior corrosion resistance with minimum maintenance is required. Grade 304 is a basic chromium-nickel stainless

steel and is suitable for rural, urban and light industrial sites. Grade 316 is a chromium-nickel-molybdenum stainless steel, the presence of molybdenum greatly improving the overall corrosion resistance and especially pitting resistance. These stainless steels are suitable for industrial and coastal sites.

Regarding basic material costs, stainless steel is the most expensive and iron the least. However, the basic material costs are only around 10-30% of the total cost of producing a cast component, so, depending on the type of casting, a stainless steel casting may cost only slightly more than an identical carbon steel casting (see Section 3.4 for more information on costs).

Table 3.1 gives the key mechanical properties of six widely used iron and steel castings.

Table 3.1 *Summary of mechanical properties for six common grades of cast metal compared to mechanical properties of hot rolled carbon steel (shown shaded)*

Property	SG iron (BS 2789)		Carbon steel (BS 3100)		Carbon steel (BS EN 10025)		Stainless steel (BS 3100)	
	350/22	400/18	AL2	A4	S275	S355	304C12	316C12
0.2% proof strength or lower elastic yield strength or yield strength ¹⁾ (N/mm ²)	215	259	275	320	275 ³⁾	355 ³⁾	180 ⁷⁾	180 ⁷⁾
Tensile strength ¹⁾ (N/mm ²)	350	400	485 to 655	540 to 690	410 to 560 ⁴⁾	490 to 630 ⁴⁾	430	430
Modulus of elasticity (N/mm ²)	169,000	169,000	203,000 to 210,000 ²⁾	203,000	210,000	210,000	186,000	170,000
Elongation ¹⁾ (%)	22	18	22	16	22 ⁵⁾	22 ⁵⁾	26	26
Charpy impact energy	17 J at 20°C	14 J at 20°C	20 J at -46°C	30 J at 20°C	27 J at 0°C ⁶⁾	27 J at 0°C ⁶⁾	8)	8)
Notes: 1) Minimum specified values 2) Typical values 3) Nominal thickness, $t \leq 16\text{mm}$ 4) Nominal thickness, $3 \leq t \leq 100$ 5) Nominal thickness, $3 \leq t \leq 40$ 6) Impact energies are for steel of quality S275J0 and S355J0 7) The Standard quotes minimum 1% proof strengths of 215 N/mm ² . The values in this table are 0.2% proof strengths, taken as 84% of the 1% proof strength (see Section 4.2.2). 8) Charpy impact energies are not appropriate as austenitic stainless steels are inherently tough materials								

3.2 Designing for production - limitations on section size, shape and thickness

If castings are not designed with production in mind, they will be difficult to manufacture, which will increase the production costs and may lower the quality of the finished article. Correct design for production can reduce costs, eliminate unnecessary weight and improve the ability of the component to withstand service stresses.

It is important to appreciate that the economic viability of castings is dependent on the costs of pattern construction. Therefore *repeatability* and *simplicity* are crucially important considerations during conceptual design. There are no general rules on the amount of repetition necessary for economic production. For example, some large nodes show economic benefit with only two similar castings from one pattern, whereas casting simple fork-end connectors typically becomes cost effective only when the number required exceeds 30-50, depending on the detail of the connector. It is also possible to make a number of alternative shapes from one pattern with differing member sizes and angles, simply by using change pieces.

If the casting is a fairly typical component, then it can be worthwhile considering use in future projects as well as just the project in hand.

There is much interaction between the various characteristics of the casting. For example, the local thickness will determine the frequency of the channels in the mould to convey molten metal, which will have an impact on the finish. The function of the casting will dictate the mechanical properties, toughness and surface finish. These factors will determine the level and frequency of testing and the acceptance criteria, all of which have a significant effect on the cost.

Although it is possible to cast virtually any shape by adopting suitable techniques in the foundry, there are certain practical requirements which should be met if production costs are to be minimised and problems of casting quality, such as hot tears, are to be avoided. Rules governing the design of castings are based upon:

- the fluidity and solidification of the metal,
- practicalities associated with the production of moulds and cores,
- finishing requirements.

3.2.1 Design for casting

Fluidity is the ability of molten metal to fill completely a mould cavity and reproduce its details. With metals of low fluidity, there is a limit to the minimum section that can be cast. The minimum thickness depends on the composition and characteristics of the mould (in particular the length and surface area of the section) and method of mould-filling (in particular the position of the thin section with respect to the gating system). For example, it is impracticable to produce plate sections which are very thin in relation to their surface area by the normal gravity casting processes.

A minimum thickness of 6 mm is generally recommended for iron and steel. (Iron castings with thicknesses down to 4-5 mm have given acceptable results.) If the

6 mm section is longer than about 300 mm, the minimum thickness should be greater (see Figure 3.2 for guidance on minimum thickness as a function of the largest dimension).

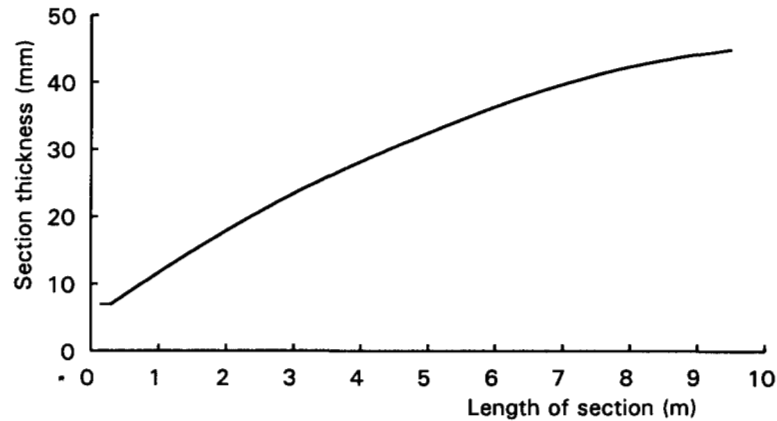

Figure 3.2 *Minimum thickness of steel castings as a function of their largest dimension*

(Steel Castings Design Properties & Applications, edited by W.J. Jackson, Castings Technology International, 1983)

Special foundry techniques can permit thinner sections to be cast in certain situations, though the costs will be higher.

There is no practical upper limit on the choice of section thickness.

3.2.2 Design for internal soundness by promoting directional solidification

The volumetric contraction which occurs within the cross-section of a solidifying cast component must be compensated by liquid feed metal from an adjoining heavier section, or from a riser which serves as a feed metal reservoir and which is placed adjacent to, or on top of, the heavier section. If there is insufficient feed metal to compensate for volumetric contraction, shrinkage cavities will form. These typically occur in parts of a mould which are fed through thinner sections - the thinner sections solidifying too quickly to permit liquid feed metal to pass from the riser to the thicker section.

In the production of a sound casting, the aim is for progressive solidification to occur from the thinner sections at the casting extremities into heavier sections towards the point of metal entry into the mould. Special aids such as tapers, padding and 'chills' may be used to encourage directional solidification. Figure 3.3 shows some examples of incorrect and correct designs to improve casting soundness.

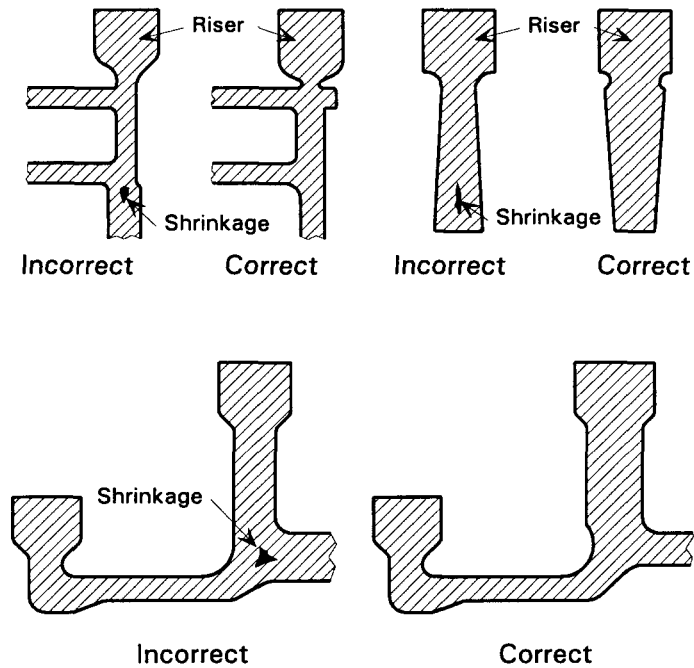

Figure 3.3 *Examples of design sections showing correct arrangements to improve casting*

(Steel Castings Handbook, 6th Ed., Steel Founders' Society of America and ASM International, 1995)

Tapering is a cost-effective way of achieving directional solidification. If design parameters do not permit the use of a taper on a casting section, then it is possible to thicken certain sections up by padding. For example, metal padding can be used to bridge the gap between one heavy section and another isolated heavy section, so that directional solidification can occur through the thinner joining member. Obviously, the use of metal padding raises production costs due to the extra metal needed and cleaning effort required to remove the metal and give a uniform surface finish. It is more cost-effective if the padding is incorporated as part of the final shape of the casting.

Chilling is another method used to reduce shrinkage. A chill fits the contour of the surface of the casting to be chilled and removes heat from the surface of the casting at a much faster rate than the surrounding mould wall.

Wherever shapes or sections join together in a casting, an increase in mass occurs at the junction. These areas of greater mass must be fed by risers, or cavities will occur. Alternatively, the design of the casting should minimise the occurrence of isolated masses, for example, by removing the centre of a heavy mass by using a core. Detailed guidance is given in References 3 and 4.

3.2.3 Design for surface integrity

Cracks or hot tears tend to occur at changes in section or junctions unless proper design rules are followed. These areas are particularly susceptible to hot tears because the larger section solidifies later and tears more readily than the adjacent thinner sections. The formation of cracks and tears necessitate costly removal, repair (*i.e.* welding, weld dressing, further inspection and heat treatment) and production delays.

To avoid cracks or hot tears, the greatest possible uniformity of thickness should be maintained. Changes in section thickness should be smooth and gradual. It is better if the change in section takes place entirely on one side of the thinner section, and in accordance with the details shown in Figure 3.4.

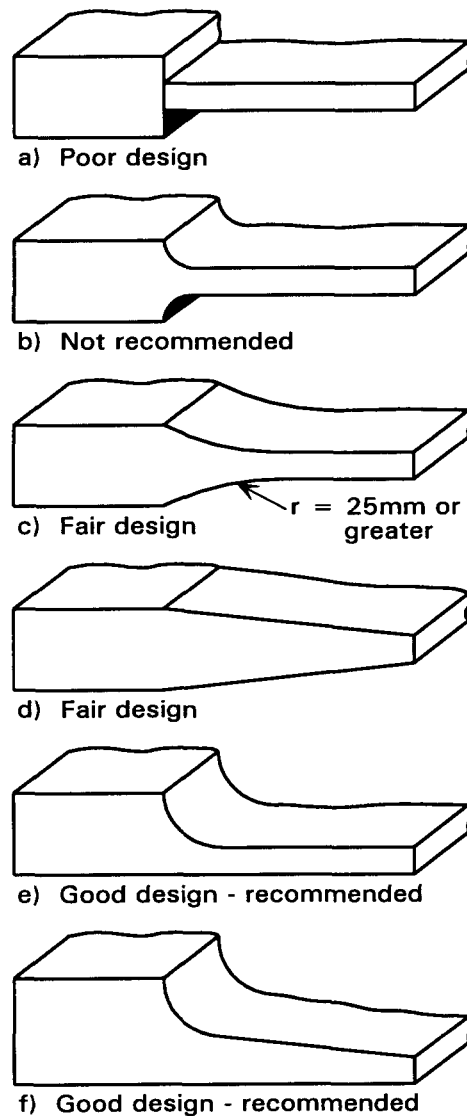

Figure 3.4 *Changing section thickness*
(Steel Castings Handbook, 6th Ed., Steel Founders' Society of America and ASM International, 1995)

3.2.4 Design for moulding

Although almost any shape of casting is possible, there are some limitations because the pattern has to be removed from the mould. For this reason, shapes which appear simple may be difficult to cast. Straight sides should be avoided because of the difficulty of removing patterns cleanly. As general guidance, a taper of not less than one degree, or 0.5 mm per 100 mm, is usually recommended. The use of tapers can lead to a reduction in the number of cores required, which reduces costs.

Patterns with straight parting lines (*i.e.* in one plane) can be produced more easily and at lower cost than those with irregular parting lines.

The minimum diameter of a core which can successfully be used in a casting depends on the thickness of the metal section surrounding the core, the core length and any special procedures used by the foundry.

Small decorative features, for architectural items, are not difficult to form on the surface of the pattern providing they are not on or near a parting line. A core will have to be used for complex features or those near mould joints. Then the basic pattern will have a simple block-like shape in place of the decorative feature and the core for the feature is then placed in the print left in the mould by this block. Such cores should be kept simple and the difficulty of placing them in the mould must be considered. For the most complex shapes, it may be simpler to weld together several separately manufactured castings.

3.2.5 Design for finishing

The ease of carrying out subsequent cleaning and finishing operations (which are labour intensive) must be considered at the design stage. The design should include openings which are sufficiently large to permit access for the removal of any cores.

3.2.6 Design for machining

If the casting requires machining, then the design must include an adequate machining allowance and ensure that there are suitable positions for clamping devices to be used during machining. The quantity of components to be produced and machined will also have an influence on the design. It is obviously important that an appropriate material and heat treatment are specified.

Section 4.4 discusses machining of castings in greater detail.

3.3 Prototyping

A prototype or sample casting is usually made to highlight any potential problems with the proposed manufacturing process and ensure that the client is satisfied with the overall appearance of the component. The prototype will be subject to the specified non-destructive testing (NDT) procedures and a rigorous dimensional audit. Any non-compliance with the requirements of the specification may lead to modifications in the production process and/or the casting design.

For castings in critical applications, a prototype is sometimes thoroughly tested to indicate whether the proposed programme of NDT can identify all the critical

defects; this usually leads to a reduction in inspection and testing requirements during production (see Sections 5.2 and 5.3). Clearly this has cost and schedule implications.

Some specialist organisations offer a prototyping service which develops components from design drawings using 3-D modelling and analytical tools, as well as producing and testing full prototypes prior to tender.

3.4 Costs

The actual cost breakdown of a casting depends on the particular application, the production route and number of castings required. As mentioned in Section 3.1.4, the basic material costs only account for 10-30% of the final cost of the casting. (For a fabricated component, the basic material costs are usually a higher proportion of the total cost, due to the cost of the rolling processes.) Items such as finishing and inspection and testing can have a significant effect on the final cost of the casting, as well as on the production schedule. The cost of the pattern as a proportion of the total cost is closely dependent on the number of castings being produced.

Figure 3.5 shows pie charts giving a notional breakdown of costs for castings required in two different projects. The first demonstrates a typical cost breakdown for a small quantity of medium weight castings and the second a large quantity of high weight castings.

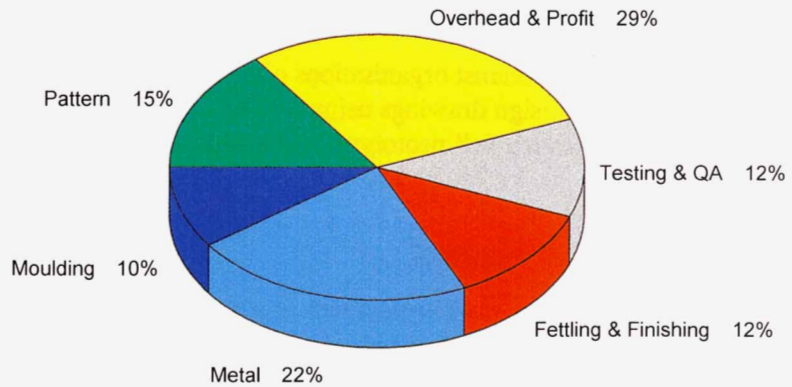

Carbon steel castings (grade A4) - small quantity - medium weight

Quantity: 5 off
 Unit weight: 235 kg
 Total value: £13,500
 Testing: First casting was subject to 100% magnetic particle and ultrasonic inspection. Thereafter, only the fillets were subject to magnetic particle inspection and critical areas tested ultrasonically.

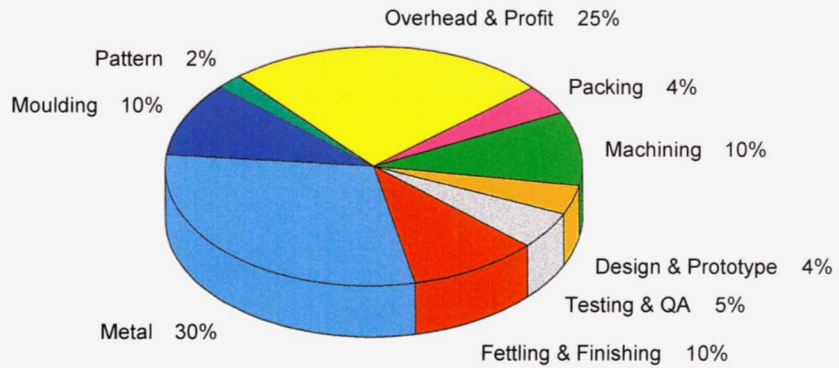

Stainless steel castings (grade 316) - large quantity - high weight

Quantity: 120 off
 Unit weight: 1200 kg
 Total value: £1,200,000
 Testing: First casting was subject to 100% penetrant flaw inspection and radiographic testing in critical areas. Thereafter, only critical areas were subject to penetrant flaw inspection.

Figure 3.5 Cost breakdown for two different cast components (source: Goodwin Steel Castings)

4 DETAILED DESIGN

4.1 Structural analysis

The stresses in a cast component induced by the dead and live loading on the structure may be determined from elastic analysis in a manner similar to that used for fabricated connections. Generally 'hand' techniques are sufficient, although certain simplifying assumptions may need to be made for complex connections. The shape and size of some structural castings are governed by aesthetic and not functional requirements, and consequently may be only lightly stressed. No rigorous structural analysis techniques are required in those cases.

For applications where a more accurate prediction of the stress distribution or deformation of the casting is required, or where fatigue endurance is a primary design consideration, theoretical or experimental stress analysis techniques may be used. Finite element methods using solid elements can effectively model the stress distribution in a casting, and thereby predict stress concentration factors, fatigue endurance and deformations. This technique permits the form of the casting to be optimised. Unless the structure is subject to fatigue loads, this approach is generally only necessary for highly stressed castings playing a critical role in the overall structure.

4.2 Structural design

4.2.1 SG Iron

There is no British Standard covering the structural design of SG iron. Reference 2 recommends permissible stresses in tension and compression, based on the supposition that the limit of proportionality should not be exceeded under nominal working loads. The limit of proportionality is between 0.6 and 0.75 of the 0.1% proof stress, depending on the grade. Table 4.1 gives the recommended values.

Table 4.1 *Permissible stresses in tension and compression for SG iron*

(Adapted from Gilbert, G N J, Engineering data on nodular cast irons -SI units, BCIRA, 1986)

Stress condition	Ferritic SG iron		All other grades of SG iron	
	Grades 350/22, 350/22L40, 400/18, 400/18L20	Grade 420/12	Grade 450/10	Grades 500/7, 600/3, 700/2, 800/2, 900/2
Direct tension	$0.75 \times 0.75 R_{p0.1}^t$ $= 0.56 \times R_{p0.1}^t$	$0.75 \times 0.70 R_{p0.1}^t$ $= 0.52 \times R_{p0.1}^t$	$0.75 \times 0.693 R_{p0.1}^t$ $= 0.52 \times R_{p0.1}^t$	$0.75 \times 0.6 \times R_{p0.1}^t$ $= 0.45 \times R_{p0.1}^t$
Direct compression	$0.75 \times 0.8 \times R_{p0.1}^c = 0.6 \times R_{p0.1}^c$			
Notes: Permissible stress = $0.75 \times$ limit of proportionality $R_{p0.1}^t$ = 0.1% proof stress in tension $R_{p0.1}^c$ = 0.1% proof stress in compression				

4.2.2 Carbon and stainless steel

For carbon steel castings, the adequacy of the proposed cast component to withstand the design loads can be determined using the provisions in BS 5950: Part 1. Equivalent guidance for stainless steel is presented in the *Concise guide to the structural design of stainless steel*⁽⁶⁾.

The design strength of the material may be taken as the 0.2% proof stress (or lower yield strength in the case of some cast carbon steels).

Then, for example, the shear capacity, P_v for a component cast from steel grade A4 is given by:

$$P_v = 0.6 p_y A_v \quad \text{BS 5950: Part 1: Clause 4.2.3}$$

where

$$\begin{aligned} p_y &= \text{design strength} \\ &= 320 \text{ N/mm}^2 \text{ (0.2\% proof strength for grade A4)} \quad \text{BS 3100: Table 5} \\ A_v &= \text{shear area} \end{aligned}$$

For stainless steels, BS 3100 only gives 1% proof strength values. However, the 0.2% proof strength is normally taken as the design strength. For austenitic grades 304 and 316, the 0.2% proof strength is about 84% of the 1% proof strength.

4.2.3 Brittle fracture

The energy absorption provisions detailed in Clause 2.4.4.3 of BS 5950: Part 1 are applicable to SG iron and carbon steel in the majority of cases. For thick sections and/or high strength grades, this approach will predict high Charpy impact energies. However, Charpy impact energies in excess of 27 J at -20°C may be impractical for the foundry to achieve; in such circumstances, the structural engineer should seek further guidance from experts in the field of structural integrity assessments.

Brittle fracture need not be considered for austenitic stainless steels because they are inherently tough materials.

4.3 Welding

Weldability of the material is important in castings both from the point of view of joining and repair (Section 5.4 gives advice on repair).

4.3.1 SG Iron

Welding SG iron is quite distinctly different from welding carbon steels. SG iron is generally difficult to join by fusion welding techniques - structural changes in the material are inevitable and the heat affected zone is hard and brittle. All welding must be carried out in carefully controlled situations and followed by heat treatment. The advice of a specialist welding engineer or authority should always be sought.

Since few foundries have the necessary qualified procedures or skilled welders to produce satisfactory welds with SG iron, it is best to avoid welding and use SG iron castings with bolted connections only.

4.3.2 Carbon steel

Cast steels have similar welding characteristics to wrought steels of comparable carbon equivalent. However, cast steels usually have higher silicon and manganese contents than their wrought steel equivalents and therefore have higher hardness and hardenability. Special care is also needed when heavy sections are involved or the castings have complicated shapes.

MMA, MIG, submerged arc and TIG are all suitable welding processes for cast steels.

As mentioned in Section 3.1.2, carbon steel castings are heat treated to produce the necessary property requirements. Depending upon the carbon content, this may consist of annealing, normalising or annealing and normalising. When the carbon content is low, it is possible to carry out welding prior to heat treatment, but in the majority of cases, welding is carried out after at least one thermal heat treatment.

Recommendations for the welding of carbon and low alloy steel castings are given in BS 4570. The weldability of steel castings is also dealt with in detail in References 3 and 4.

The mechanical properties of welds joining cast steel to cast steel and of welds joining cast steel to wrought steel are of the same order as similar welds joining wrought steel to wrought steel, providing the materials are of similar composition.

Where castings are to be welded, either to themselves or to other structural members, it is essential that correct welding procedures are developed and used. These need to reflect the particular joint configurations, steel chemistry (as defined by the carbon equivalent), *etc.* General guidance on the development of procedures can be found in BS 5135 and BS 4570. The procedures should be qualified to a recognised standard, such as BS EN 288.

4.3.3 Stainless steel

Austenitic stainless steels have excellent weldability both to themselves and to carbon steels. Inert-gas-shielded welding processes are used in addition to metallic-arc and gas welding. Since the steels are non-hardenable, neither pre-heat nor post-heat is needed to ensure good welds, although post-weld heat treatment is used to obtain the required mechanical properties, for stress removal and for improving corrosion resistance. Care should be taken in selecting the correct weld consumable to meet the strength and corrosion requirements whilst preventing the formation of hot cracks during cooling of the weld metal. Specialist advice should be sought from the manufacturer of the welding consumable.

The thermal conductivity of stainless steels is about one third that of carbon steel and the thermal expansion coefficient is about 50% greater. This low conductivity results in the retention of local heat for longer times, and the high coefficient of expansion means that higher residual stresses and more distortion can be expected.

For welding thicker sections (> 15 mm), lower carbon grades (*e.g.* 304C12 and 316C12) or a niobium stabilised grade (*e.g.* 347C17) are more appropriate, due to

their greater resistance to sensitisation (reduction in corrosion resistance) in weld heat affected zones.

As for carbon steels, it is essential that correct welding procedures are developed and used (see Section 4.3.2).

4.3.4 Inspection of welds

Depending upon specified requirements, it may be necessary to inspect castings to ensure freedom from defects introduced during the welding operation. The more common processes are ultrasonic and radiographic inspection, which are used for the detection of sub-surface defects such as porosity, slag and cracks. Magnetic particle inspection is normally used to detect surface-breaking defects such as cracks.

4.4 Machining

SG iron, carbon steel and stainless steel castings can all be readily machined. Low strength, low hardness, a brittle structure, a coarse grain structure and soft non-metallic inclusions all tend to lead to good machining characteristics in a casting. Manufacturing procedures can affect the machinability of castings, for example macroscopic sand, slag and refractory inclusions impair machinability.

The surface of a sand-moulded casting wears a cutting tool rapidly, possibly because of adherence of abrasive mould materials to the casting. Therefore the initial cut needs to be deep enough to penetrate below the skin, or, alternatively, the cutting speed can be reduced to 50% of that recommended for the base material. However, once the surface is removed, the machinability is no different to that of a wrought metal of similar composition and in a similar condition of heat treatment.

The machinability of SG iron with a tensile strength of up to about 550 N/mm² is better than that of cast carbon steel. At higher strengths, the difference in machinability between SG iron and cast steel is less pronounced.

Particular care is required in machining stainless steels because of their tendency to work harden. Cutting lubricants are essential.

4.5 Dimensional tolerances

Dimensional accuracy is required in order to reduce rejects, limit weld rectifications, cut machining costs and facilitate assembly of castings. Tolerances are affected by the material, casting design, pattern equipment, moulding process and quantity of castings required. Post-casting operations such as mould stripping, fettling and heat treatment can cause variations in casting dimensions, for example by excessive metal removal or heat distortion.

It is extremely difficult to predict the metal contraction of a cast component in all directions. Furthermore, there are variations in mould hardness and mould stability at elevated temperatures which may cause mould wall movement, and an increase in mould volume. Minimum dimensional tolerances can therefore only be achieved

by progressive modification and so are not cost-effective for non-repetitive work. The closer the tolerances specified and the greater the number of dimensions with very close tolerances, the higher the cost of the piece. However, specifying tight tolerances can save on machining costs. The structural engineer and fabricator are advised to consult the foundry about the most cost-effective way of obtaining the required dimensional tolerances.

In general, greensand moulding is the least precise, followed by drysand, shell and investment moulding in order of increasing accuracy. Metal and resin patterns are more accurate than wood patterns.

The mould layout affects the dimensional consistency because increased tolerances are needed where the dimension crosses a mould joint, a mould joint and a core, or two or more cores. With normal jointed moulds, dimensional accuracy is improved where mould joints and cores are kept to a minimum and the most critical dimensions are formed in the same half of a mould.

For critical dimensions, a foundry may be able to achieve closer tolerances than normally possible by, for instance, applying special measures which control the position of the core in the mould or altering the pattern after production of pilot castings. Although these add to the cost of the casting, they may well reduce the cost of the finished part.

BS 6615 specifies the tolerances applicable to dimensions of metal castings produced by different moulding processes. The Standard introduces various tolerance grades (CT4 to CT13) which relate to tolerances corresponding to a series of basic casting dimensions. However, the figures quoted in the Standard are generally inappropriately large for structural applications and values of ± 1 to ± 5 mm are more suitable.

Figure 4.1 shows a cable band casting for the Tsing Ma Bridge undergoing a dimensional audit.



Figure 4.1 Cable band casting for the Tsing Ma Bridge undergoing a dimensional audit

4.6 Surface finish

As with dimensional accuracy, surface finish is dependent on the alloy being cast, the size of component, the type of mould, the method of finishing, *etc.* Moulds with fine impenetrable surfaces give the smoothest surface, for example castings made in plaster, investment or ceramic moulds have smoother surfaces than those from conventional sand moulds. Smooth castings are likely to be more expensive than those with a rougher finish. In sand castings, the type of sand used has a significant effect on the surface quality of the casting. Iron castings usually give a better surface finish than steel castings.

Surface finish requirements should be discussed with the founder early in the contract. While surface finish may not have a great effect on the structural performance of the casting, it can be a very important consideration for the end-user. Clearly, the type of surface finish which is acceptable on a two tonne base is quite unlikely to be acceptable for an architectural detail.

It is important to remember that uniformity of surface finish is also desirable. When the appearance of the casting is critical, feeder heads, runner systems, *etc.* should be located in positions which will not be prominent in the final assembled structure since it is difficult for an exact match and consistency in surface finish to be obtained by hand grinding. Very smooth surface finishes should only be specified for critical faces of a casting; the highest standards of surface finish may not always be achievable all over the casting.

Surface finish of castings is specified using visual or tactile replicas of a standard range of actual cast surfaces. The use of tactile comparators is better than simply

referring to photographs because the depth of surface irregularities can be compared more accurately.

There are three specifications in common use:

- *MSS-SP-55 Quality standards for steel castings for valves, flanges and fittings and other piping components - visual methods* - the specification consists mainly of photographs of different types of surface conditions. It is widely used throughout the casting industry. MSS-SP-55 has one acceptance level which should be achievable on all sand castings. This level is midway between ASTM A802 levels II and III.
- *ASTM A802 Standard practice for steel castings, surface acceptance standards, visual examination* - this standard gives four different acceptance levels, all based on the CTI comparators.
- *CTI (formerly known as SCRATA) Comparators for the Definition of Surface Quality of Steel Castings⁽⁷⁾* - these are tactile comparators; no acceptance levels are given. The replica plates represent various features found on steel castings, such as surface texture, gas porosity and non-metallic inclusions.

Further guidance on acceptance levels is given in Section 5.3.

4.7 Surface treatment

Surfaces can be treated or coatings applied in order to provide protection against corrosion, fire, wear, galling, *etc.* However, special finishes should only be specified where absolutely necessary, since they may greatly increase the cost of a component and can have a significant impact on the production schedule because finishing is often subcontracted out of the foundry.

Regarding the application of paint, the most important factor influencing the life of a paint is the proper preparation of the surface to be painted. When paint has lifted off a surface, it is usually due to chemical or electrolytic action underneath, caused by some contaminant which was not removed. In large components where descaling is difficult, an etch primer or phosphate primer can be used. In applying such a primer, metal reacts with it to form an insoluble complex phosphate. Primers may be applied by dipping, spraying or brushing. Polymer binders are contained in the primer, which seal the coating and form suitable pre-treatment surfaces for subsequent painting.

Heat tint forms on the surface of carbon and stainless steels after heat treatment or welding due to interference colours being set up by the thickening oxide layer. Although not a concern for carbon steel components because they are invariably painted, heat tint in stainless steels is undesirable. Even if discolouration is aesthetically acceptable, there is some uncertainty regarding whether its removal is necessary to maintain corrosion resistance. It does not seem generally important to remove heat tint for service in atmospheric conditions where the steel offers a good margin on resistance to that required for the particular environment. Removal of heat tint can be costly; if required, a pickling and passivation procedure should be followed. Local heat tint can be removed by polishing.

Surface finish is also important for carrying out various non-destructive tests and has an effect on the ability to interpret results obtained from magnetic particle and ultrasonic examination. For magnetic particle inspection, all surfaces to be tested should be free from scale, dirt, grease or paint and should be shot blasted or chemically cleaned. It is also advantageous for surfaces to be lightly ground, especially fillet radii. For ultrasonic examination, loose scale and excessive roughness should be removed and any local grinding should be carefully carried out to avoid ridges and hollows which make probe contact difficult. Cast surfaces should not be peened or fettled by hammering prior to ultrasonic examination.

5 INSPECTION AND TESTING

The extent of inspection and testing is specified by the structural engineer and depends on the process of casting manufacture and the foundry's usual testing procedures (which can vary considerably from foundry to foundry). If castings are to be provided to the correct quality at an economic price, then it is essential that inspection and testing are limited to those features which are relevant to the service use of the casting. This applies both to the methods specified, the extent to which they are invoked and whether inspection can be restricted to certain parts of the casting.

The significance of the casting within the overall structure should also be considered when planning the inspection programme. The shape and size of some castings are determined by aesthetic and not functional considerations, and so although a member is critical to the integrity of the structure, it may be subject to such low stresses that extensive inspection is inappropriate. The case histories in *Appendix C* illustrate this point; the beam to column nodes in the buildings at New Square, Bedford Lakes operate at very low stresses because they were sized for appearance. A less extensive programme of inspection and testing was therefore appropriate than for castings operating closer to their structural capacity.

5.1 Verification of mechanical properties

BS 2789 and BS 3100 are written with castings for general engineering purposes in mind; great care must be exercised when applying them to structural castings. In particular, they only require that the minimum specified mechanical properties apply to test bars (also known as keel blocks) cast at the same time as the piece, and not the piece itself. The limits in the specifications were established by the evaluation of the results from thousands of these standard test bars. To remove test bars from the casting itself is impractical because it would destroy the usefulness of the component or require costly weld repairs to replace the material removed for testing purposes.

However, the properties of test bars can only give *approximations* of the properties of the finished castings. For example, the cooling rate for small individually cast blocks is normally greater than for heavy wall castings; both corrosion resistance and tensile properties are sensitive to cooling rate. Furthermore, the response to heat treatment can be different because of differences in cross-section or thickness. For this reason, separately cast test bars with cross-sections significantly different from those of the casting do not provide an adequate check on mechanical properties for structural applications, although they are probably sufficient for architectural details and castings which are subject to low stresses.

These difficulties can be overcome to a certain extent by testing coupons which are larger than normal and that have cooling rates more representative of those experienced by the piece being produced (*e.g.* test bars with sections $t \times t \times 3t$, where t is the nominal thickness of the casting). It is generally preferable, however, for the structural engineer to specify in the procurement documents that the integrity of the casting be verified by testing blocks cast-on to the casting. In some situations

it is not possible to cast integral test coupons because they may have an adverse effect on the casting itself, for example in a thin section where the test coupon will affect the cooling rate or induce residual stress. In these cases, the structural engineer should specify that the test blocks should accompany the castings they represent during all heat treatment processes (option B.17 of BS 3100).

An alternative approach is to cast a prototype alongside some separate test blocks, all manufactured according to the proposed production method. The prototype is examined for cracks and holes using the proposed non-destructive techniques, test loaded beyond its working load and areas of high strain noted. The prototype is then dissected and re-inspected on the cut surface to determine whether there are any defects not revealed by the conventional non-destructive tests. Samples are then cut from the loaded prototype and mechanically tested along with test bars cut from the test blocks. This approach will give an indication of how closely the mechanical properties of the test blocks predict those of the cast piece.

The usual mechanical tests carried out on SG iron are tensile, elongation and hardness. Impact tests are only carried out on a couple of grades, and then only when specified. Tensile, elongation, impact and hardness tests are routinely carried out on carbon steel. The frequency of testing for mechanical properties is typically once per ladle for batch melting, or once per 3 tonnes for continuous melting.

If the notched bar impact tests indicate toughness values below those required in the specification, then COD (crack opening displacement) tests can be carried out to BS 5762. A fracture mechanics analysis based on the COD data and the maximum size of defect permitted within the NDT regime can then investigate whether the casting is fit for purpose. The analysis may conclude that more stringent defect acceptance criteria need to be specified. PD 6493⁽⁸⁾ gives relevant information on fracture mechanics methods for assessing the acceptability of flaws in structures. COD tests are fairly time-consuming and costly, so the impact of a COD test programme on the overall project schedule should be carefully considered.

5.2 Non-destructive testing - an introduction to the main methods

A number of non-destructive examination and testing techniques are used by foundries to ensure that the product complies with the specification.

No single method of NDT can survey all defect situations. For this reason non-destructive testing techniques are often used in a complementary manner, *e.g.* magnetic particle inspection will show a surface crack while ultrasonics will measure its depth, or ultrasonics may reveal a defect and radiography will show its identity.

As described in Section 5.1, for castings which are very highly stressed, or critical to the integrity of the structure, thorough testing of a prototype may be carried out in order to investigate whether the proposed programme of examination can identify all the critical defects; this will usually lead to a reduction in examination and testing requirements. Alternatively, a fracture mechanics assessment based on COD (crack opening displacement) test data can be carried out to define more clearly the toughness of the material. (Reference 8 gives guidance on methods for this.) This

information will be useful in defining appropriate acceptance levels, techniques and frequency for the NDT regime. Occasionally, fracture mechanics methods may be used to investigate whether a casting containing defects larger than the maximum permitted size is fit for purpose.

Prior to inspection by any method, it is essential that the surface of the casting is suitably prepared; BS 4080 gives guidance on this (see also Section 4.7).

The following sections summarise the main techniques of non-destructive testing used on castings. Halmshaw⁽⁹⁾ gives further information. Table 5.1 summarises the strengths and weaknesses of penetrant flaw, magnetic particle, ultrasonic and radiographic inspection methods.

Table 5.1 *Summary of strengths and weaknesses of the most common non-destructive test methods*

(Adapted from Introduction to the non-destructive testing of welded joints, R Halmshaw, The Welding Institute, 1988)

Method	Advantages	Disadvantages
Magnetic particle	Sensitive to fine cracks	Ferromagnetic materials only
	Inexpensive	Surface breaking defects only
Dye penetrant	Sensitive to fine cracks	Needs prior surface cleaning
	Inexpensive	Surface breaking defects only
	Any material	
Ultrasonics (manual)	Can detect fine cracks	No direct flaw image
		Totally reliant on operator
		Not suitable for austenitic stainless steels
Radiography	Direct image of flaws	Slow, high cost
	Applicable to all metals	Potential safety hazard
		Limited ability to detect fine cracks

5.2.1 Surface inspection methods

Visual inspection

Visual inspection is generally carried out with the unaided eye in good lighting. Surface imperfections such as sand inclusions and cold laps can be detected visually, but pinhole porosity, cracks and hot tears cannot.

Magnetic particle inspection

Magnetic particle inspection is a cheap, simple, yet sensitive method of detecting cracks which reach the surface of a casting. The casting is first magnetised to produce magnetic lines of force in the material. Fine iron particles are then applied either in dry powder form, or in a suspension in a liquid medium. The particles accumulate at discontinuities, such as cracks, due to highly localised magnetic fields set up in these regions.

Magnetic particle testing is only applicable to magnetic materials; austenitic stainless steels are non-magnetic and therefore cannot be inspected using this method.

Penetrant flaw inspection

Penetrant flaw inspection is a sensitive and cheap method of detecting defects open to the surface. The surface of the casting must be cleaned thoroughly prior to testing because any foreign matter or oxide coating may hide a defect. Liquid is put on the surface of the casting and given time to soak into surface-breaking cracks and cavities. Surplus liquid is then removed from the surface and any liquid which has entered cracks *etc.* is made visible by a developer, fluorescence or seepage.

Penetrant flaw detection can be used on all steels, but it is generally only used on non- or slightly magnetic steels such as austenitic or duplex stainless steels.

5.2.2 Sub-surface inspection methods

Ultrasonic inspection

Ultrasonic impulses are sent into the casting from special probes. Attenuation and echoes of the impulses are monitored to determine the presence and location of defects. Cracks and linear discontinuities, as well as holes larger than 3 mm can be detected. Ultrasonic inspection by manual methods depends on the skill of the operator for correct calibration, application and interpretation of the displayed signals in order to estimate the nature and size of the defects. Nevertheless, it is often used as a rapid and economical check of casting soundness.

Austenitic stainless steels cannot be inspected by ultrasonic methods; the grain size in the cast product is much too large, which causes the ultrasound to be refracted.

Radiographic inspection

This method involves placing a film immediately behind the casting with a source of radiation directed towards the casting from the other side. The source may be gamma or X-rays. The wavelength of the radiation is sufficiently short to allow a proportion of the radiation to pass through the metal to reach the film. The amount of radiation absorbed depends on the thickness and density of the metal. Thus differences in the thickness of the metal due to the presence of flaws will lead to a difference in exposure on the film.

It is important to note that any flaws which do not affect the thickness of the metal will not be detected. Hence, radiography is good at detecting volumetric non-planar flaws such as porosity; planar flaws which are aligned to the direction of the beam and are not closed tightly together can also be detected. However, planar flaws inclined at an angle to the beam or hairline cracks cannot be detected.

Radiography produces an image directly related to the flaws, which is usually easy to interpret. It also provides a hard copy record of inspection. It is useful for inspecting castings with complex shapes. However, radiography is slow and expensive, particularly for thick castings.

Since it is much more expensive than ultrasonic inspection, it is important to consider how much radiographic coverage is required and in which areas the radiograph should be located in order to detect the most probable defects. Radiographic examination is more usual with cast steels, partly because the results are easier to interpret than those obtained with cast iron.

5.3 Non-destructive testing - guidance on typical specification requirements and acceptance levels

For every non-destructive test, the following should always be carefully specified:

- i) The type of test and the relevant standard
e.g. Magnetic particle inspection to BS 6072
- ii) The acceptance level
e.g. Level 2 in weld areas and Level 3 elsewhere (quality levels specified in BS 4080: Part 1)
- iii) The coverage required
e.g. Fillet areas, changes in section and all weld areas
- iv) Quantity of castings to be inspected
e.g. One in every five castings

Overly conservative specification, *i.e.* full inspection of every casting, or a blanket requirement for elimination of all types of defect from every area of the casting, is inappropriate. The choice of acceptance level should be based on an evaluation of the design and stress distribution under anticipated service conditions. Many castings are not subject to high stresses and very onerous acceptance levels for surface flaws (unless the casting is clearly visible and architecturally important) or sub-surface flaws should not be specified.

The same acceptance levels need not apply to all areas of a casting, or to all types of defect. Some types of defect are more detrimental than others, depending on the nature of the stress to which the casting is subject in service. However, it is important to ensure that the areas of a casting which are to be welded to other structural members are subject to more rigorous inspection and more stringent acceptance levels than the rest of the casting.

For investment castings, shell moulded castings and the weld ends of sand castings, it is likely that the highest acceptance level quoted in the relevant standard for the particular method of test would be appropriate. However, depending on the stresses within the component, for large sand castings it is likely that a lower acceptance level would be adequate.

Sections 5.3.1 to 5.3.5 give details of typical specification requirements and acceptance levels for the common non-destructive testing methods.

5.3.1 Visual inspection

Acceptance level

ASTM A802 gives acceptance levels for surface finish. The standard refers to the CTI graded reference comparators (Reference 7) for the visual determination of surface texture, discontinuities, *etc.*

There are four acceptance levels in ASTM A802. Level I is the most stringent and is more likely to be applicable to shell-moulded castings and any castings which are architecturally important. For the surfaces of sand castings which are not architecturally important and for sand castings over 500 kg in weight, less onerous acceptance levels may be more appropriate, such as levels II or III.

Coverage

100% coverage of all accessible areas is typically required.

Quantity of castings to be inspected

All castings should be visually inspected.

5.3.2 Magnetic particle inspection

Specification for test method

Magnetic particle inspection should be carried out in accordance with BS 6072.

Acceptance level

BS 4080: Part 1 gives acceptance levels for magnetic particle inspection. For each of the five acceptance levels, a maximum allowable defect size for non-linear and linear defects is given. The maximum size for linear defects increases as the wall thickness of the casting increases. Note that the standard uses the term *severity level* in place of acceptance level (the terminology adopted in this guide). The Standard states that levels 1 and 2 are only suitable for precision castings (*e.g.* investment and shell moulded castings) and should be specified with care. Acceptance level 5 is rarely appropriate for castings in construction.

A minimum defect size to be considered during the test is also quoted for each acceptance level, *e.g.* for level 1, the size of the smallest defect to be considered is 1.5 mm and for level 2 the corresponding figure is 2 mm.

Coverage

Depending on the criticality of the application, typical options are:

- i) 100% coverage of all accessible areas
- ii) Fillets, changes in section and weld areas
- iii) Weld areas.

Quantity of castings to be inspected

Depending on the criticality of the application, typical options are:

- i) Every casting
- ii) 1st off sample castings
- iii) One in every 5 castings
- iv) Castings selected at random.

5.3.3 Penetrant flaw detection**Specification for test method**

Penetrant flaw detection should be carried out in accordance with BS 6443.

Acceptance level

BS 4080: Part 2 gives acceptance levels for penetrant flaw inspection. For each of the five acceptance levels, a maximum allowable defect size for non-linear and linear defects is given. The maximum size for linear defects increases as the wall thickness increases. Note that the standard uses the term *severity level* in place of acceptance level (the terminology adopted in this guide). The Standard states that levels 1 and 2 are only suitable for precision castings (*e.g.* investment and shell moulded castings) and should be specified with care. Acceptance level 5 is rarely appropriate for castings in construction.

A minimum defect size to be considered during the test is also quoted for each acceptance level, *e.g.* for level 1, the size of the smallest defect to be considered is 1.5 mm and for level 2 the corresponding figure is 2 mm.

Coverage

Depending on the criticality of the application, typical options are:

- i) 100% coverage of all accessible areas
- ii) Fillets, changes in section and weld areas
- iii) Weld areas

Quantity of castings to be inspected

Depending on the criticality of the application, typical options are:

- i) Every casting
- ii) 1st off sample castings
- iii) One in every 5 castings
- iv) Castings selected at random.

5.3.4 Ultrasonic examination**Specification for test method**

Ultrasonic inspection should be carried out in accordance with BS 6208 using compression probes and FBH (flat bottom hole) reference blocks. For critical applications, angle probes may be used but this significantly increases the inspection time.

Acceptance level

BS 6208 gives four acceptance levels for ultrasonic inspection. For each level, a maximum allowable defect size for planar and non-planar defects is given. The maximum size increases as the wall thickness increases. Acceptance level 4 is rarely appropriate for castings in construction.

Coverage

Depending on the criticality of the application, typical options are:

- i) 100% coverage of all accessible areas
- ii) Fillets, changes in section and weld areas
- iii) Weld areas.

Quantity of castings to be inspected

Depending on the criticality of the application, typical options are:

- i) Every casting
- ii) 1st off sample castings
- iii) One in every 5 castings
- iv) Castings selected at random.

5.3.5 Radiographic inspection**Specification for test method**

Radiographic inspection should be carried out in accordance with ASTM E94 *Guide for radiographic testing*.

Acceptance level

Acceptance levels for radiographic inspection are given in DIN 1690 *Technical delivery conditions for castings made from metallic materials Part 2 Steel castings; classification into severity levels on the basis of non-destructive testing*. (There is no equivalent British Standard; the DIN standard is likely to form the basis for the new European Standard.) Four acceptance levels are given, though level 4 is rarely appropriate for castings in construction.

DIN 1690 makes reference to ASTM standard radiographs which are in common use in most countries.:

- ASTM E446 for wall thicknesses less than 50 mm
- ASTM E186 for wall thicknesses from 50 to 115 mm
- ASTM E280 for wall thicknesses from 115 to 300 mm.

Coverage

Depending on the criticality of the application, typical options are:

- i) 100% coverage of all accessible areas
- ii) Fillets, changes in section and weld areas
- iii) Weld areas.

Quantity of castings to be inspected

Depending on the criticality of the application, typical options are:

- i) Every casting
- ii) 1st off sample castings
- iii) One in every 5 castings
- iv) Castings selected at random.

5.4 Repair

It is common practice to repair (commonly termed 'upgrade') defects in steel castings by welding. When unacceptable surface or internal faults (*e.g.* air voids or lumps of entrapped sand) are detected, they are typically removed by cutting out with an arc-air lance. The cavity can then be filled with sound metal by welding using a consumable that ensures compatibility with the original cast material. After repair, heat treatment needs to be carried out to temper the metallurgical structure and eliminate residual stresses introduced by welding operations.

Repair of steel castings by fusion welding is covered by BS 4570. Manual metal arc (MMA) methods with coated electrodes are widely used. Low hydrogen electrodes, shielding gases such as CO₂ and argon, and submerged arc and electro-slag methods are also suitable.

Repairs in iron castings are generally confined to non-critical areas, *i.e.* surface irregularities, and not to internal faults. Most cast iron repairs are carried out by MMA welding.

Weld repairs should have no adverse effects on the integrity of castings because they are carried out under controlled shop conditions to qualified procedures and are followed by controlled heat treatment. Any qualification to the extent of welding or the circumstances under which it can be used must be specified by the structural engineer, *e.g.* 'any single repair requiring an excavation greater than a certain size or in an area indicated on a drawing is not permitted without specific approval'.

Following any rectification, the repaired area should be ground or machined flush and re-examined by the methods and to the acceptance criteria specified *e.g.*:

- visual inspection to BS 5289,
- magnetic particle testing to BS 6072,
- ultrasonic examination to BS 3923: Part 1.

6 PROCUREMENT

6.1 Procurement route

The founder is responsible for choosing a method of manufacture that produces a casting to the requirements in the specification in an economical and efficient way. It is the responsibility of the architect, structural engineer and fabricator to state their requirements clearly, and ensure that these requirements are appropriate for the type of casting being ordered. It is extremely important that early discussions are held between the parties so that the implications of the various processes and desired quality requirements are fully understood, taking due account of project schedule and cost.

Many end-users of castings tend not to require such tight tolerances, so particular care is needed in agreeing these requirements with the founder. Foundries are more familiar with call-off orders to retained patterns than orders involving pattern development within a fast-track programme, which is typical of a construction project.

Casting supply is usually entirely within the structural steelwork contract, *i.e.* the fabricator is responsible for purchasing the castings from the foundry. In certain situations, for special or one-off castings, the structural engineer may wish to procure castings directly from a foundry.

As with any custom-made item, it is advisable to allow as much time as possible between ordering and the required delivery date. Although feasibility and costs may be discussed at an early stage, foundries often complain that too little lead time is given between the placing of the order and the required delivery date. Typical lead-in times are 6-8 weeks from finalisation of the approved casting construction drawings. On standard details, such as fork-ends, where patterns are 'off-the-shelf', deliveries can be within 4-5 weeks.

Foundries normally keep their patterns, so that if the fabricator deals with a foundry with some experience of architectural or structural work he or she may be able to buy an item almost 'off-the-peg'. Cast iron stair treads are a good example of an architectural standard item.

The following flowcharts show the sequence of activities and parties responsible for each activity in the procurement of a structural casting. The flowcharts divide the procurement process into four main phases:

- Developing the design.
- Describing the design.
- Engaging a fabricator and foundry.
- Production and quality control.

Appendix G lists a number of foundries and the types of castings they produce. The foundries listed all have some experience of producing structural castings for the construction industry.

6.2 Procurement specification

Great care is needed in developing the procurement specification in order for the required quality to be obtained without over-specifying, which would lead to unnecessary cost and delays in delivery. It is important that full details of quality requirements are agreed as early as possible.

As a baseline, the following must be covered in a specification:

- material composition
- mechanical properties
- surface finish
- dimensional tolerances
- testing and examination requirements
- rectification procedures
- heat treatment.

Appendix B gives guidance notes on key issues that should be addressed in a specification for a cast structural component.

6.3 Castings for standardised simple connections

The casting process can prove to be a cost-effective way of manufacturing simple connections, providing relatively large numbers are required in order to offset the initial costs of tooling. Standardised cast connections with proven strength capacities are obtainable 'off-the-shelf' from some fabricators. Typical delivery times are around a month. Examples include fork-end connectors for hollow sections and tension rods or tee connections for portal frame structures.

Fork-end connectors were used in the roof truss joints at Stansted Airport. Experience on this project indicated that casting the fork-ends, as opposed to fabricating them, became cost-effective when the quantity required exceeded 30-50, depending on the detail of the connector.

Procuring a Structural Casting - Part 1: Developing the Design

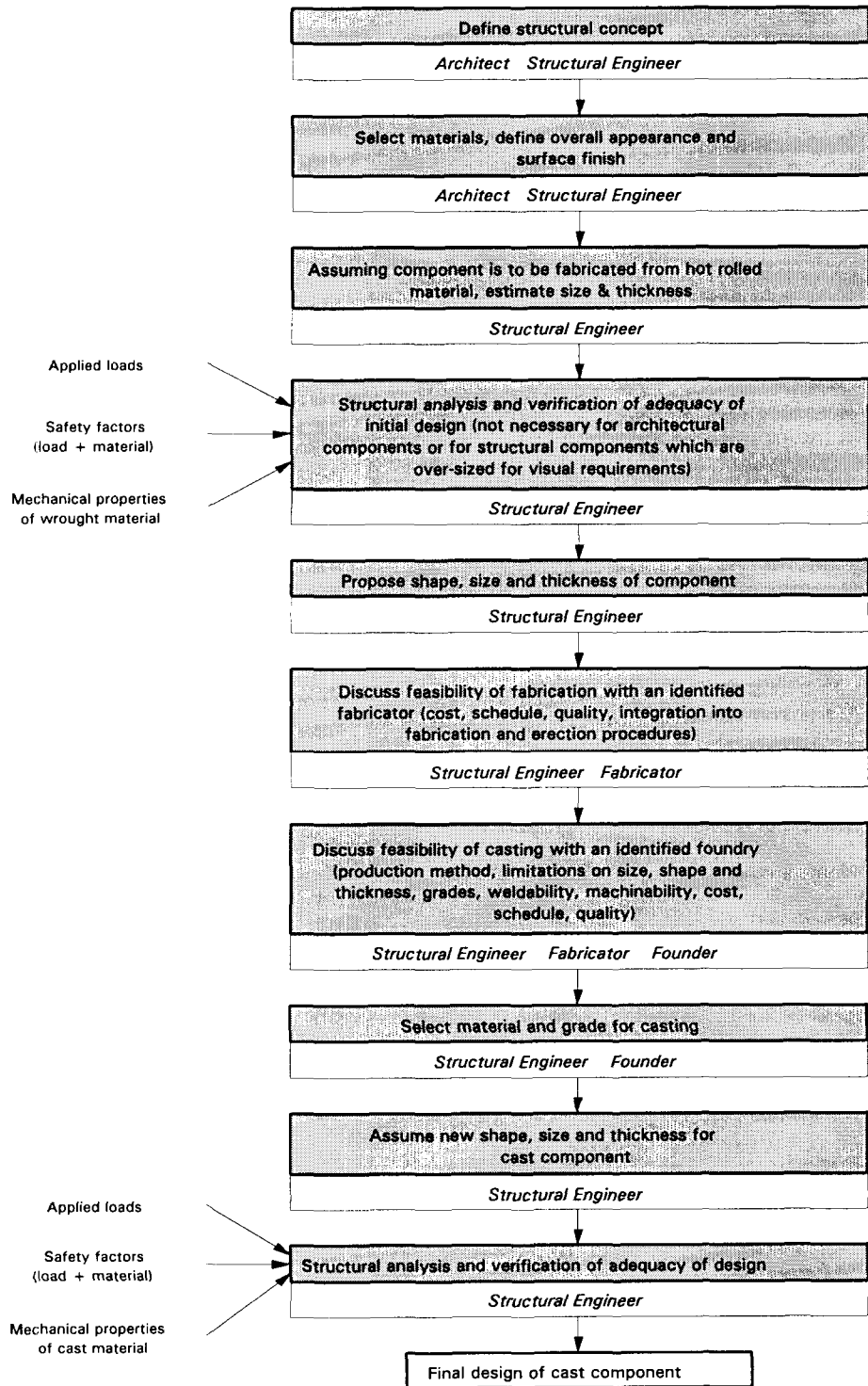

Note: Part 1 refers to activities prior to contract award. The structural engineer will approach one or more identified fabricators and foundries to ask for advice on construction and casting issues.

Procuring a Structural Casting - Part 2: Describing the Design

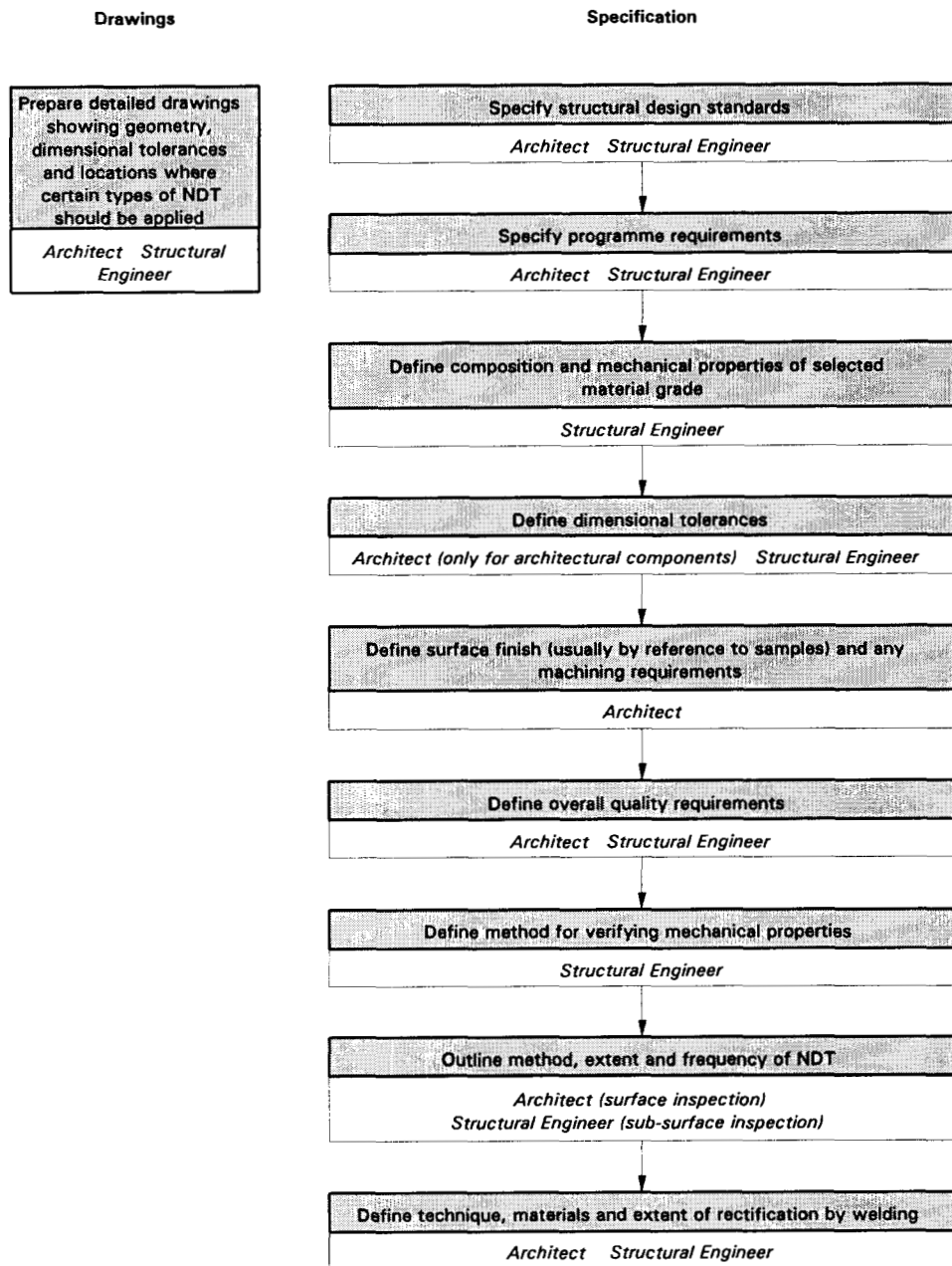

Note: Part 2 refers to activities prior to contract award

Procuring a Structural Casting - Part 3: Engaging a Fabricator & Foundry

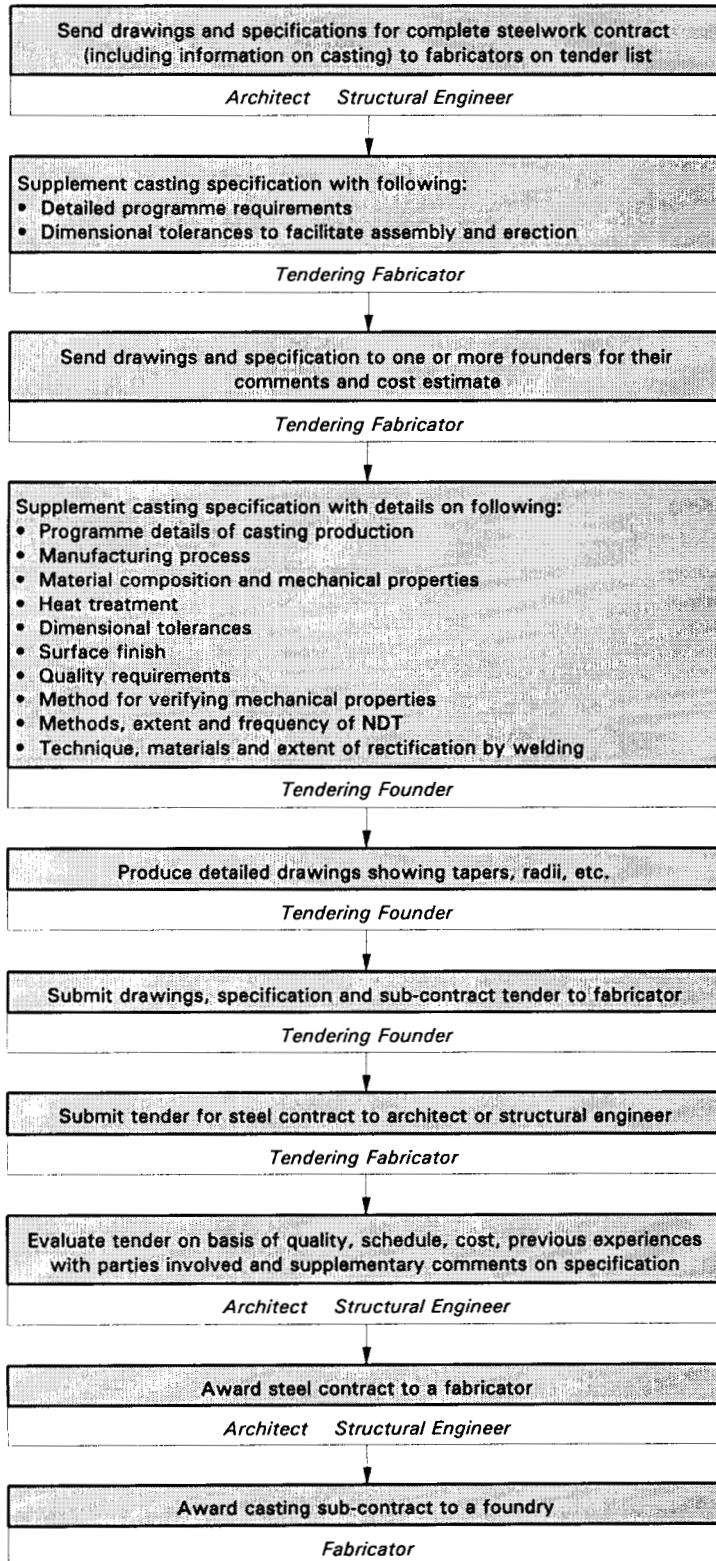

Procuring a Structural Casting - Part 4: Production & Quality Control

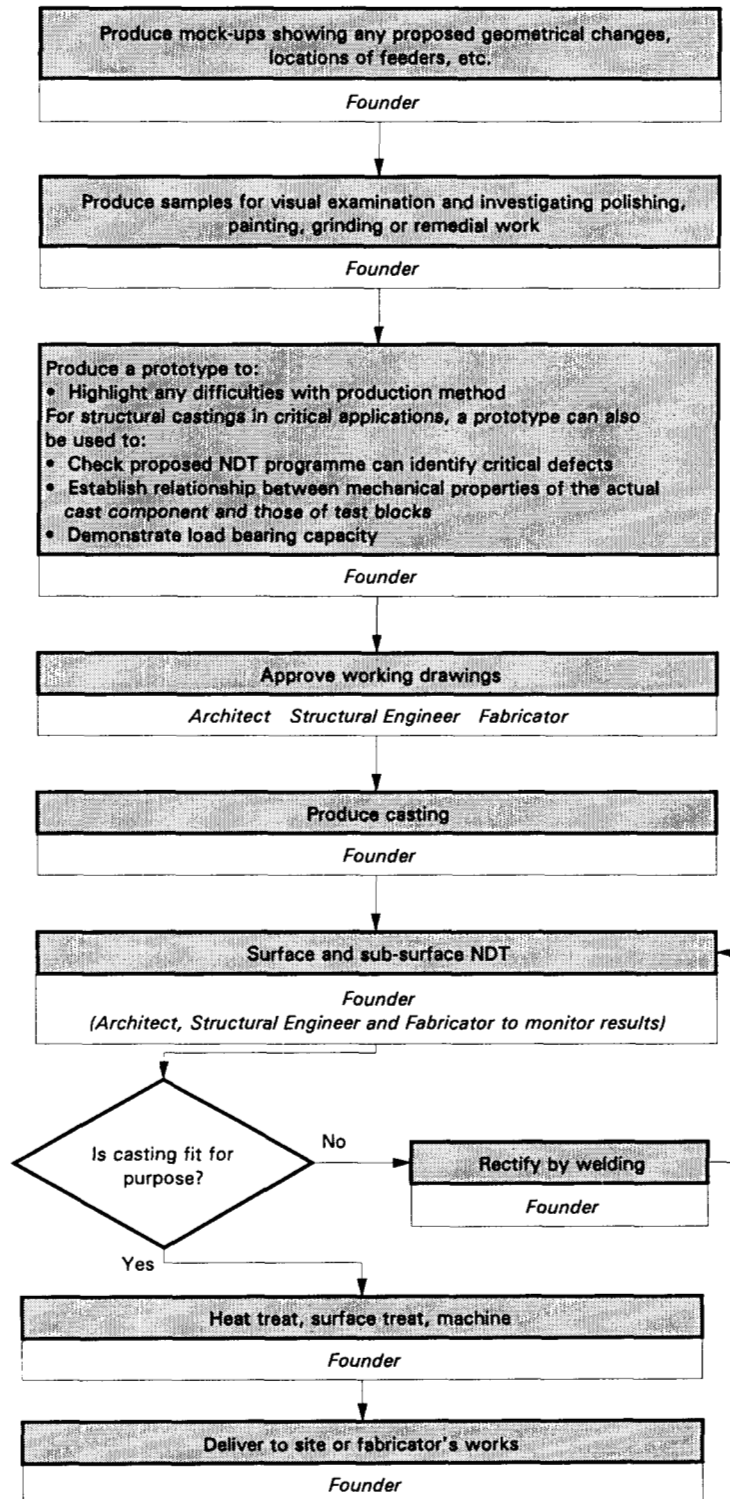

7 REFERENCES

For a list of relevant published standards, see Appendix E.

1. **BUSSELL, M.**
Appraisal of existing iron and steel structures
The Steel Construction Institute, 1996
2. **GILBERT, G. N. J.**
Engineering data on nodular cast irons - SI units
BCIRA, 1986
3. **JACKSON, W. J.**
Steel castings design properties and applications
Steel Castings Research and Trade Association, 1983
4. **Steel Castings Handbook**
Sixth Edition, Steel Founders' Society of America and ASM
International, 1995
5. **Kempe's Engineer's Yearbook**
Section C5, 97th Ed, Benn Business Information Services Limited, 1992
6. **BURGAN, B. A.**
Concise guide to the structural design of stainless steel
The Steel Construction Institute, 1992
7. **CASTING TECHNOLOGY INTERNATIONAL LIMITED**
Comparators for the definition of surface quality of steel castings
CTI, 1982
8. **BRITISH STANDARDS INSTITUTION**
PD 6493 Guidance on methods for assessing the acceptability of flaws in
fusion welded structures
BSI, 1991
9. **HALMSHAW, R.**
Introduction to the non-destructive testing of welded joints
The Welding Institute, 1988

APPENDIX A

Mechanical and physical properties

This appendix gives mechanical and material properties for six grades of iron and steel castings which are commonly used in structural applications. The grades covered are:

- Iron grades 350/22 and 400/18, to BS 2789
- Steel grades AL2 and A4, to BS 3100
- Stainless steel grades 304C12 and 316C12, to BS 3100

The fatigue strength of cast nodes may be assessed in accordance with BS 7608 *Fatigue design and assessment of steel structures* and the Department of Energy Guidance Notes¹.

The corrosion resistance of cast iron, steel and stainless steel is similar to that of their wrought counterparts; guidance prepared for the wrought metals may be directly applied to the cast metal.

¹Department of Energy
Offshore Installations Guidance on Design, Construction and Certification
Fourth Edition, 1990

A.1 Iron

Properties of SG iron		Grade 350/22	Grade 400/18
Minimum specified properties [†] (BS 2789)			
Tensile strength	N/mm ²	350	400
0.1% proof strength (in tension)	N/mm ²	203	247
0.1% proof strength (in compression)	N/mm ²	226	270
0.2% proof strength (in tension)	N/mm ²	215	259
0.2% proof strength (in compression)	N/mm ²	229	273
Elongation	%	22	18
Brinell Hardness		107-130	120-140
Representative physical properties⁽²⁾			
Impact properties (V-notched according to BS 131: Part 2)			
Start of ductile to brittle transition	°C	-10°C to +30°C	-10°C to +30°C
Minimum impact value at 20°C	J	17	14
Modulus of elasticity	N/mm ²	169,000	169,000
Poisson's ratio		0.275	0.275
Density (typical values)	kg/m ³	7,100	7,100
Specific heat capacity	J/kgK		
	20°C to 200°C	461	461
	20°C to 700°C	603	603
Coefficient of thermal expansion	10 ⁻⁶ /K		
	20°C to 200°C	11.0	11.0
	20°C to 400°C	12.5	12.5
Thermal conductivity	W/mK		
	100°C	36.5	36.5
	500°C	35.8	35.8
[†] Note that the minimum specified properties apply to separately cast or attached test blocks and not to the castings themselves.			

A.2 Steel

Properties of steel		Grade AL2 ¹⁾	Grade A4
Minimum specified properties † (BS 3100)			
Tensile strength	N/mm ²	485 to 655	540 to 690
Lower yield stress or 0.2% proof strength	N/mm ²	275	320
Elongation	%	22	16
Brinell Hardness		140 to 185 ²⁾³⁾	152 to 207 ³⁾
Charpy impact energy	J °C	20 -46	30 20
Representative physical properties⁽³⁾¹⁾			
Modulus of elasticity	N/mm ²	203,000 to 210,000 ²⁾	203,000
Density (typical values)	kg/m ³	7,820 to 7,850 ²⁾	7,830
Specific heat capacity	J/kgK	420-460	420-460
Coefficient of thermal expansion	10 ⁻⁶ /K		
	20°C to 200°C	-	12.32
	20°C to 400°C	-	14.44
	20°C to 600°C	14.25-14.50	
Thermal conductivity	W/mK 100°C	46.9 (approx)	46.9 (approx)
<p>† Note that the minimum specified properties apply to separately cast or attached test blocks and not to the castings themselves.</p> <p>1) If attached test blocks are used, the mechanical properties can only be expected in those cases where the maximum section thickness of the casting is less than 500 mm. Where castings include sections of greater thickness the structural engineer should agree, with the founder, the mechanical properties to be obtained from such test blocks.</p> <p>2) Typical values.</p> <p>3) Brinell hardness is only required if requested by the structural engineer and stated on the order.</p>			

A.3 Stainless steel

Properties of steel		Grade 304C12	Grade 316C12
Minimum specified properties [†] (BS 3100)			
Tensile strength	N/mm ²	430	430
1% proof strength ¹⁾	N/mm ²	215	215
Elongation	%	26	26
Charpy impact energy	J	- ²⁾	- ²⁾
Representative physical properties⁽³⁾			
Modulus of elasticity	N/mm ²	186,000	170,000
Density (typical values)	kg/m ³	7,710 (approx)	7,710
Specific heat capacity	J/kgK 20°C	501	502
Coefficient of thermal expansion	10 ⁻⁶ /K as cast	16.2	-
	20 to 100°C	-	16.0
	20 to 500°C	-	17.5
	20 to 540°C	18.0	-
Thermal conductivity	W/mK		
	100°C	15.75	15.9
	500°C	-	20.4
	540°C	20.95	-
[†] Note that the minimum specified properties apply to separately cast or attached test blocks and not to the castings themselves.			
1) The 0.2% proof strength should be used as the design strength. For these grades, the 0.2% proof strength can be taken as 180 N/mm ² (~84% of the 1% proof strength).			
2) Charpy impact energies are not appropriate as austenitic stainless steels are inherently tough materials.			

APPENDIX B Key issues which require addressing in a specification for a cast structural component

This appendix presents the key issues which must be addressed in a specification for a cast component. Indications of the options available for iron, carbon steel and stainless steel castings are given wherever possible.

Activity	Requirement	Standard or reference	Comments
1. Design	The structural design of the casting should comply with the relevant standard.	SG iron - <i>Engineering data on nodular cast irons</i> ⁽²⁾ Carbon steel - BS 5950: Part 1 Stainless steel - <i>Concise guide to the structural design of stainless steel</i> ⁽⁶⁾	
2. Programme	The founder should provide a detailed programme.		The programme should cover the following work items: <ul style="list-style-type: none"> • preparation and submission of manufacturing information • order and delivery of materials • pattern-making • production of samples/prototypes • casting • weld repairs • machining • final validation of quality and conformance
3. Manufacturing process	The founder should decide on the most appropriate manufacturing process that will enable the most effective use of material to achieve the required casting shape, quality and surface finish.		Close liaison between structural engineer, fabricator and founder is necessary.
4. Material - composition	The composition of the cast material should comply with the relevant standard.	SG iron - BS 2789 Carbon steel and stainless steel - BS 3100	For example: BS 2789: 1991 iron 400/18L20 <i>or</i> , BS 3100: 1990 steel A2 <i>or</i> , the founder's own proprietary alloy having the same properties and provided according to the requirements of BS 2789 or BS 3100.

Activity	Requirement	Standard or reference	Comments
5. Material - mechanical properties	<p>The cast material should be certified to have the following mechanical properties:</p> <ul style="list-style-type: none"> • UTS • 0.2%/1% proof strength • Elongation • Charpy impact energy • Hardness HB 	BS 2789 BS 3100	<p>If the Charpy impact energies do not meet the specification, COD (crack opening displacement) tests can be carried out to demonstrate whether the casting is fit for purpose.</p> <p>Modifications to the mechanical properties quoted in the specification for a given grade should be clearly highlighted.</p>
6. Heat treatment	The heat treatment should give the cast material the mechanical properties and weldability specified.		Options include annealing, normalising or annealing and normalising at suitable temperatures. SG iron is not usually heat treated.
7. Dimensional tolerances	Work should be carried out within the dimensional tolerances, including machining allowances, specified by the structural engineer and fabricator.	BS 6615	<p>The datum points for machining and measuring should be given on the drawings.</p> <p>If the tolerances specified in BS 6615 are not small enough, the founder should submit for approval to the structural engineer /fabricator a detailed list of tolerances to which the work should be executed within the requirements of the specification and the overall geometry of the structure.</p> <p>Typical tolerances are ± 2 mm on external surfaces and ± 1 mm on wall thickness.</p>
8. Surface finish	The founder should remove all burrs, tack welds and other marks using defined procedures. Accessible surfaces shall be free from adhering sand and heat treatment scale.	CTI comparators <i>Acceptance levels -</i> ASTM A802	CTI graded reference comparators are widely used with ASTM A802 acceptance levels.

Activity	Requirement	Standard or reference	Comments
9. Quality control - General	The founder should operate an inspection system to verify that all materials, workmanship and completed work conform with the specified requirements.		<p>Test certificates should be verified by an approved independent Inspecting Agency.</p> <p>The founder should ensure that all personnel performing inspections and tests have appropriate qualifications, experience or training.</p> <p>The founder should keep records of all tests on operatives, procedural trials and tests on materials and workmanship and make these records available to the structural engineer/fabricator for examination.</p>
10. Quality control - Verification of mechanical properties	The tensile and impact properties of the casting should be verified.	BS 2789 BS 3100	<p>The frequency of testing should be specified, <i>e.g.</i> tests should be carried out on one casting from each ladle for batch melting, or in each 3 tonnes for continuous melting.</p> <p>The specimens to be tested must be carefully specified, options include:</p> <ul style="list-style-type: none"> representative test blocks with ruling sections equivalent to those of the castings they represent <i>or</i> cast-on test blocks which are not detached until the heat treatment has been completed <i>or</i> a prototype casting manufactured exactly according to the proposed manufacturing process.
11. Quality control - Non-destructive testing	The founder should carry out non-destructive testing to verify the integrity of the casting.		<p>The methods of testing, coverage, quantity of castings to be tested and acceptance levels should be agreed between the structural engineer/fabricator and founder.</p> <p>The specification should clearly state whether the structural engineer/fabricator expect the founder to pay for the testing.</p>
<i>Surface inspection - visual</i>	Visual surface inspection should comply with the relevant standard.	CTI comparators <i>Acceptance levels - ASTM A802</i>	The extent of inspection should be specified, <i>e.g.</i> 100% visual inspection to CTI standard A1 in accordance with ASTM A802.

Activity	Requirement	Standard or reference	Comments
<i>Surface inspection - magnetic particle</i>	Magnetic particle inspection should comply with the relevant standard. This method cannot be used on austenitic stainless steel castings.	<i>Technique</i> - BS 6072 <i>Acceptance levels</i> - BS 4080: Part 1	The extent of inspection should be specified, <i>e.g.</i> all castings should be inspected at all accessible fillets and changes of section and in all areas indicated by the drawings. An appropriate quality level must be specified, <i>e.g.</i> Level 2, BS 4080: Part 1 for weld ends.
<i>Surface inspection - penetrant flaw</i>	Penetrant flaw inspection should comply with the relevant standard.	<i>Technique</i> - BS 6443 <i>Acceptance levels</i> - BS 4080: Part 2	The extent of inspection should be specified, <i>e.g.</i> all castings should be inspected at all accessible fillets and changes of section and in all areas indicated by the drawings. An appropriate quality level must be specified, <i>e.g.</i> Level 2, BS 4080: Part 2 for weld ends.
<i>Ultrasonic inspection</i>	Ultrasonic inspection should comply with the relevant standard. This method is not usually used on austenitic stainless steel castings.	<i>Technique and acceptance levels</i> - BS 6208	The frequency of testing should be specified, <i>e.g.</i> 100% ultrasonic testing should be carried out for the first two castings of each kind with the remainder checked by ultrasonics on a 100 mm grid basis. An appropriate quality level must be specified, <i>e.g.</i> BS 6208 quality level 2 for planar discontinuities and quality level 1 for non-planar discontinuities in the outer zones.
<i>Radiographic inspection</i>	Radiographic inspection should comply with the relevant standard.	<i>Technique</i> - ASTM E94 <i>Acceptance levels</i> - DIN 1690: Part 2 <i>Reference radiographs</i> - ASTM E446 ASTM E186 ASTM E280	As an alternative to ultrasonic testing, it may be necessary to specify radiographic inspection for some areas of a casting, <i>e.g.</i> to validate the ultrasonic inspection or give a hard copy record of the material integrity or to inspect areas which cannot be ultrasonically inspected. The extent of radiographic testing should be determined from the results of the ultrasonic inspection and is typically one radiograph per casting. An appropriate quality level must be specified, <i>e.g.</i> ASTM E446 level 1 for weld ends.

Activity	Requirement	Standard or reference	Comments
12. Rectification by welding - General	Rectification by welding should comply with the relevant standard.	Iron - ANSI/AWS D11.2.89 Steel - BS 4570 & BS 5135	<p>Any qualification as to the extent of welding or the circumstances under which it can be used, must be specified by the structural engineer/fabricator, <i>e.g.</i> rectification by welding is either:</p> <ul style="list-style-type: none"> a) permitted at founder's discretion, b) permitted with permission from the structural engineer/fabricator, c) not permitted in areas shown on the drawing, d) not permitted without approval from the structural engineer /fabricator where an excavation greater than a certain size, <i>e.g.</i> 75x15x15 mm, is required, or e) not permitted in any part of the casting.
13. Rectification by welding - Non-destructive testing of repair welds	Following any rectification, the area of repair should be ground or machined flush and the casting should be re-examined in the area of repair by the methods and to the acceptance criteria specified.	Visual inspection - BS 5289 Magnetic particle test - BS 6072 Ultrasonic inspection - BS 3923: Part 1	<p>The extent of testing should be specified, for example:</p> <p><i>Magnetic particle</i> - the weld and 50 mm adjacent area, <i>Ultrasonics</i> - all welds and the volume of metal extending a further 25 mm beyond the boundaries of the repaired weld.</p> <p>An appropriate quality level should be specified, for example:</p> <p><i>Magnetic particle</i> - any undercut is to be intermittent and not greater than 0.5 mm deep, the sum of diameters of piping or porosity is not to exceed 10 mm in any weld, <i>etc.</i>, <i>Ultrasonics</i> - BS 6208 quality level 1 for non-planar discontinuities in the outer zones.</p>
14. Rectification by welding - Weld consumables	All welding consumables used for the rectification and repair of castings should be approved by the structural engineer/fabricator.		Welding consumables and procedures are to be such as to give mechanical properties for the deposited weld metal of a (stress relieved) condition not less than the minima specified for the casting in the fully treated condition.

APPENDIX C Detailed case histories

C.1 *The Western Morning News Headquarters, Plymouth*

1) *Project summary*

The building is enclosed by a doubly-curved glass facade which allows the complete newspaper production process, from journalist to delivery van, to be visible from the outside. The complex three dimensional geometry of the glass facade necessitated a steel support structure with considerable adjustment capability. Curved bony external columns ('tusks') formed from two circular hollow sections and connected by tapering sideplates are a major feature of the building. The building was completed on time and on budget in December 1992.



Western Morning News Headquarters

2) Type of casting (size, function, etc.)

Two types of castings are used in this building. The first is a four-legged spider-shaped stainless steel glazing boss which supports the glass cladding via a fixing system. The glazing boss in turn is supported by 2 m long cast iron structural glazing arms fanning out to each side of the tusk column, and a 600 mm long cast strut directly behind each tusk. These castings provide the horizontal restraint to the glazing necessary to resist the wind load. The weight of the glass, the boss and the arms themselves are supported by 16 mm diameter stainless steel hanger rods.



SG iron glazing arms

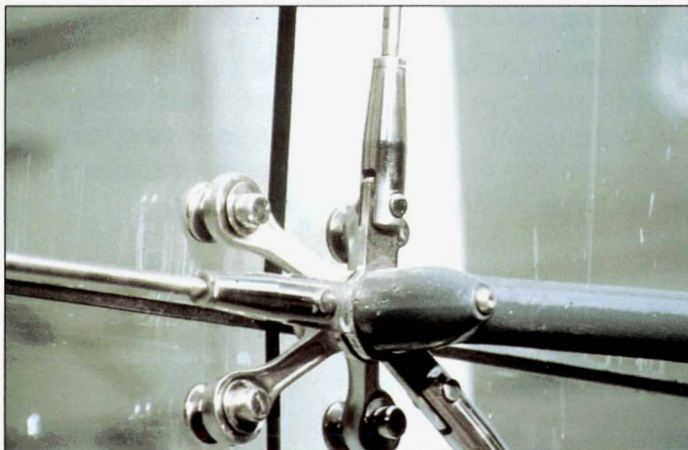

Stainless steel glazing boss

3) Why castings were selected

Casting gave the architect the freedom to specify non-standard, 'organic' shapes which fitted the overall concept theme. A high quality finish was required for the stainless steel bosses and this was obtained by using the "lost wax" casting process followed by polishing. The architect expressed an early interest in using a casting process for the glazing arms and struts because they were highly repetitive components. They were moulded by the sand casting process which produced a textured finish.

4) Material specification

The arms were cast in SG iron, grade 400/18L20 to BS 2789. The following mechanical properties were required:

Ultimate Tensile Strength	400 N/mm ²
0.2% Proof Stress	250 N/mm ²
Elongation	18%
Charpy Impact Energy	12 Joules at -20°C
Hardness HB	< 179

The stainless steel glazing bosses were cast in grade 316 material.

5) Quality control

Mechanical tests on the iron castings were carried out on one casting from each ladle for batch melting, or in each 3 tonnes for continuous melting.

The following non-destructive examination was specified for the iron castings:

- (i) Magnetic particle surface inspection.
- (ii) Ultrasonic inspection to BS 6208 to quality level 1 for planar discontinuities and quality level 1 for non-planar discontinuities in the outer zones.
- (iii) Radiographic inspection to BS 4080. Extent determined from results of ultrasonic tests.

6) Particular problems encountered and overcome

The required lengths of the glazing arms varied from 2.00 m to 1.91 m and this was catered for by providing a straight segment in the casting which was segmentally shortened in the mould. The change in angle on plan from the straight side to the curved side was also catered for by adjusting a similar straight segment on the mould at the fixing position at the end of the arm.

The iron castings did not meet the specified Charpy impact energy requirements. Therefore, COD (crack opening displacement) tests were carried out. A fracture mechanics analysis based on the results of these tests confirmed that the castings were fit for purpose.

7) Parties involved in the project

Client:	Western Morning News Company
Architect:	Nicholas Grimshaw & Partners Ltd
Structural engineer:	Ove Arup & Partners
Steelwork contractor:	Blight & White Partnership
Foundry:	John Smith (glazing bosses)

C.2 Waterloo International Rail Terminal Trainshed Roof Structure



Waterloo International Terminal

1) Project summary

Waterloo International Terminal serves the Channel Tunnel Rail Link to Europe. The roof of the trainshed is a single span, asymmetrical three-pinned arch which twists and turns for 400 m. The span of the trusses was dictated by the track/platform spacing and varied from 35 m to 49 m. The mid-span pin is positioned to create a major truss approximately twice the span of the minor truss. Both trusses reduce in size towards the pin positions. The major truss has double top compression booms, while the minor truss has a single bottom compression boom. The roof structure and its cladding were completed, along with the remainder of the terminal, in May 1993, on time and within budget.

2) *Type of casting (size, function, etc.)*

Four types of casting were used on the project:

- (i) 3×36 steel castings as the main pinned connections between the trusses forming the three-pinned arch. These were cast using resin setting sand.
- (ii) 360 'torpedo' shaped steel castings for internal truss tension nodes (the tension booms were solid rods). These were also cast using resin setting sand.
- (iii) Approximately 5000 fork-end connectors for the diagonal ties (which were solid rods) to form pin-ended connections. These were cast by the lost wax process.
- (iv) Precision stainless steel cast bosses with detachable arm sections for supporting the cladding to the roof structure. These were also cast by the lost wax process.

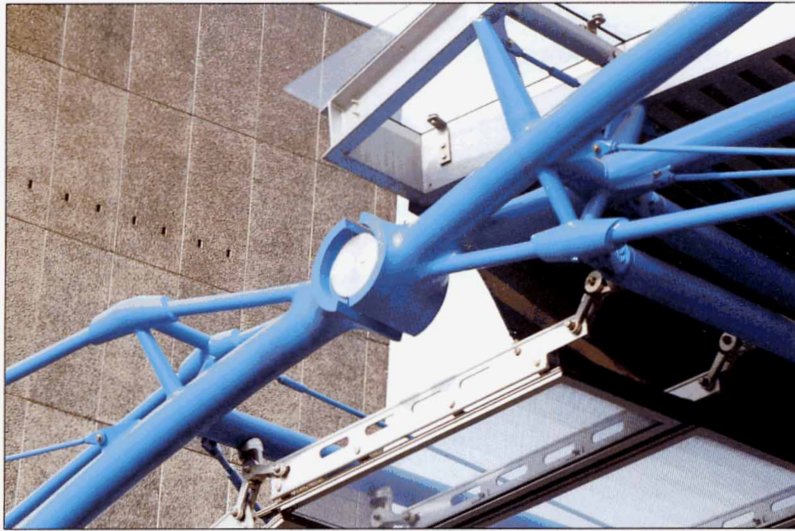

Main truss pin cast connection and 'torpedo' shaped castings for internal truss tension nodes



Stainless steel glazing connection

3) *Why castings were selected*

- (i) The main truss pin connections were initially designed with large plates and complicated welds. However, a casting offered a more structurally efficient shape. The setting out of the trusses ensured that as many details as possible were repeated at each gridline. Casting therefore provided a simple and cost-effective solution to a difficult junction.
- (ii) Alternative methods of connection were evaluated for the internal truss tension nodes, but a casting was chosen on the basis of ease of fabrication/assembly, appearance and cost.
- (iii) The large quantity of fork-ends required resulted in a casting being approximately 25-30% cheaper than an equivalent machined fork-end.
- (iv) Regarding the stainless steel casting, a complex connection was required to provide angular adjustment which, together with a sliding stainless steel rod, gave the assembly the ability to accommodate the manufacturing and erection tolerances of the steelwork structure. Again a casting provided a cost-effective solution, allowing the component to be produced as a one piece finished.

4) *Material specification and dimensional tolerances*

The carbon steel castings in (i), (ii) and (iii) were made from A4 grade steel to BS 3100. The following mechanical properties were required:

Ultimate Tensile Strength	540 N/mm ²	
0.2% Proof Stress	320 N/mm ²	(355 N/mm ² for fork-ends)
Charpy Impact Energy	20 J at -15°C	(27 J at -15°C for fork-ends)

The stainless steel castings were cast in grade 316 material.

For castings (i) and (ii) the tolerances designated in BS 6615 were regarded as inappropriate and the following tighter dimensional tolerances were specified: ± 2 mm for the external surface and ± 1 mm for the wall thickness.

5) *Quality control*

Castings (i) and (ii) underwent visual inspection to standard A1 in accordance with ASTM A802. (The surface finish of all the castings was important due to their visibility.) Magnetic particle testing was carried out to BS 6072 on all internal radii as this was seen as a critical area. An ultrasonic testing programme to BS 6208 was also carried out on the samples. The first two sample castings were rigorously inspected and after these samples were approved, one in ten was ultrasonically tested to ensure the continuity of production technique. The acceptance standards adopted in BS 6208 were level 1 for the first 75 mm from weld preparation ends and level 2 for the remainder of the casting. If any of the castings did not meet the acceptance criteria, two more from the particular batch would be inspected. If either of these were then found to be defective, inspection of the complete batch would be carried out.

The fork-ends were shotblast in a rotating blaster and then subject to ultrasonic testing to BS 6208 Level 1. The rate of testing was 5 per 120/140 components.

6) Particular problems encountered and overcome

The complex geometry of the structure meant that potentially a large number of variations of casting size might have been required for each type of casting. However, by scaling the truss dimensions down, the geometry at most connections of the truss remained constant for all trusses, despite the varying spans. The numerous truss configurations were rationalized into four different structural types, with only two variations on the external diameter of the main boom member.

7) Parties involved in the project

Client:	British Rail plc
Architect:	Nicholas Grimshaw & Partners Ltd
Structural engineer:	Anthony Hunt Associates
Steelwork contractor:	Westbury Tubular Structures
Foundry:	Noel Village (castings in main truss) Cronite (fork-ends) MBC Precision Castings (glazing connections)

C.3 Tees Barrage Bridge

1) *Project summary*

As a result of an architectural competition, an unusual tubular steel bridge design was selected to support the concrete highway bridge deck across the Tees Barrage. The bridge has eight spans, each comprising four curved arch trusses fabricated from tubular members and embellished by circular infill stiffening beams. The total span of the bridge is 150 m. The bridge was designed to carry the highest standard loading specified by the Department of Transport so that future industrial development would not be restricted in any way. The bridge was opened in 1995.

2) *Type of casting (size, function etc)*

The smaller circular infill members were solid steel castings with an outside diameter of 1180 mm and a circular cross-section of diameter 225 mm. These castings act as compression members transferring the deck load from the top chord through to the bottom chord. The flat attachment plates were formed as an integral part of the casting and were taken through the tubular sections to minimise the problem of punching shear. At the piers the tubular members were joined together and pinned to the support by cast bottom pivot plates.

In total there were 64 circular castings, each of which weighed approximately 1.6 tonnes and 44 base castings each weighing 0.75 tonnes. The total weight of castings on the project was approximately 135 tonnes, and that of the structural steelwork (hollow sections and plate) was approximately 550 tonnes. This is a high proportion of castings to structural steel.



Tees Barrage Bridge



Circular infill casting



Base casting

3) Why castings were selected

The smaller circular infill members could not be bent to the tight radius required, so a solid steel ring casting with a circular cross-section was adopted. This provided an economical solution, since the component was repeated 64 times throughout the structure.

4) Material specification and dimensional tolerances

The circular castings and bottom pivot plates were made from a modified grade A4 steel with a Charpy impact energy of 27 J at -20°C . A carbon equivalent value of less than 0.465 was specified to ensure that the metal was readily weldable with no tendency to crack.

The guidelines for dimensional tolerances given in BS 6615 were regarded as far too loose for this type of specialist steelwork. Tolerances were agreed between the founder and fabricator and generally lay between ± 2 and ± 5 mm, depending on the dimension.

5) Quality control

Mechanical tests were carried out on one casting from each ladle for batch melting, or in each 3 tonnes for continuous melting.

The following NDT was specified for the steel castings:

- (i) Magnetic particle surface inspection.
- (ii) Ultrasonic inspection to BS 6208 to quality level 1 for planar discontinuities and quality level 1 for non-planar discontinuities in the outer zones.
- (iii) Radiographic inspection to BS 4080. Extent of inspection determined from results of ultrasonic tests.

6) Particular problems encountered and overcome

During the heat treatment and subsequent cooling down process, distortion occurred causing the circular casting to twist. This led to a fabrication problem as the tubular members were slotted to accept the spades of the casting, which meant that wider slots had to be made with significantly larger welds necessary to fill the gap areas.

7) Parties involved in the project

Client:	Teesside Development Corporation
Architect:	The Napper Partnership
Structural engineer:	Ove Arup & Partners
Steelwork contractor:	Westbury Tubular Structures
Foundry:	Blackett Hutton

C.4 New Square, Bedford Lakes

1) Project summary

IBM's three buildings at New Square are steel-framed with floor beams set within the thickness of the floor slab. (This technique is called *slim-floor* construction.) They each have a gridded facade of clearly expressed columns and beams and a secondary grid of window mullions, spandrel panels and fixed window louvres. Overall stability of the buildings is provided by sheet steel shear panels bolted into the facade. A rigorous fire engineering assessment permitted the omission of fire protection to much of the structural frame. The project was completed in 1992.

2) Type of casting (size, function, etc.)

Castings form the major beam to column connections at each floor level. They fit at the head of each column and are reinforced by a bold X shape; their size is approximately 700 mm long by 300 mm high by 125 mm thick. Site welding was not considered desirable in view of the construction time required and difficulties of quality control, so a site bolted connection was designed with two flat 'hands' projecting either side of the casting to hold the floor beams by means of prominent round-headed bolts. Since the castings break the columns into single flights, the adoption of a change of section for each floor did not incur cost penalties.



New Square

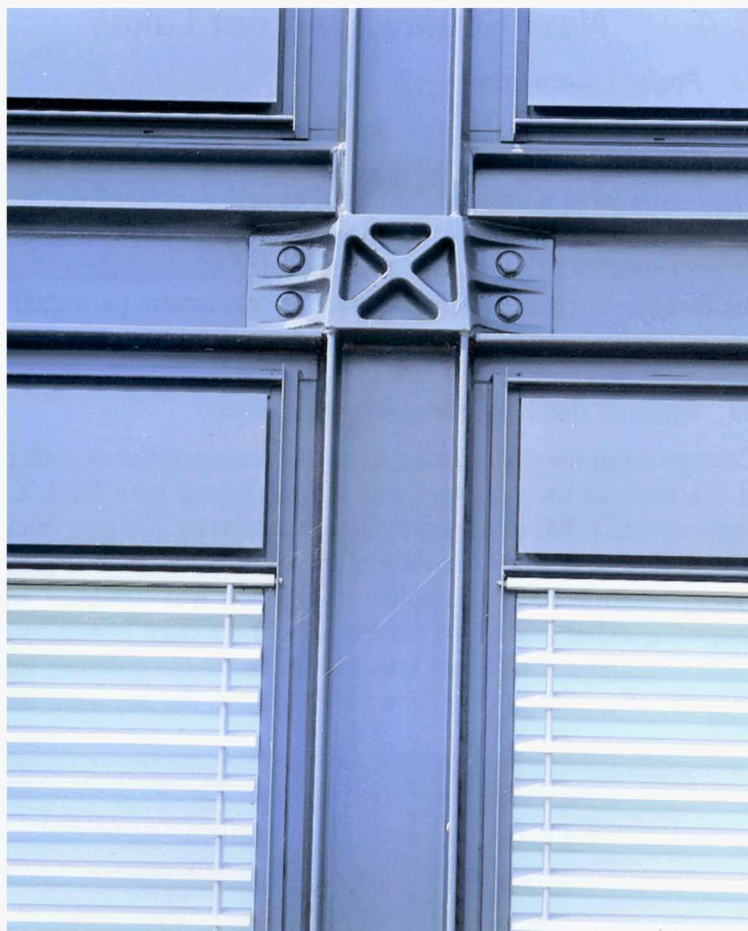

Beam to column cast connection

3) Why castings were selected

As the architect chose to adopt a theme of exposed steelwork, the beam to column connection was a very important feature. The architect was keen that the steel frame represented the real structural expression of the building and its loads. Consequently the cast node and its simple bolted connection are the true structural expression of the transfer of the loads from the beam to column. Expression of the frame in this way reduced the need for more visually elaborate cladding. A casting was selected mainly on aesthetic grounds to provide a functional and distinctive connection. At tender stage, a welded fabricated node and a cast node were priced by tenderers. There was little cost difference between the two alternatives.

A casting also enabled further complex refinements in the detailing of the node to be incorporated at no extra cost to the casting and junction:

- a reveal on the back of the casting provides a continuous protected slot for weather-sealing the bolted-up joint with silicone.
- a recessed area around the external bolt head provides a protected space for a neoprene washer seal.

4) Material specification and dimensional tolerances

The castings were steel grade AL1 steel to BS 3100. (This is a grade of steel suitable for use at low temperatures.) A carbon equivalent value of 0.38 was specified. Mechanical properties were as follows:

Ultimate Tensile Strength	430 N/mm ²
0.2% Proof Stress	230 N/mm ²
Elongation	22%
Charpy Impact Energy	20 J at - 40°C

Critical surfaces were machined flat for subsequent welded connections.

5) Quality control

Initially, ultrasonic tests were specified for the first ten castings of every pattern, in order to establish internal integrity. Having done this, internal testing was reduced to one per twenty. Surface testing by magnetic particle methods was initially specified for all castings, but this was reduced to one in twenty once it was appreciated that surface flaws were not critical to the structural performance and that a visual inspection was sufficient to reveal visually significant flaws. As the castings were sized to meet visual criteria, they were subject to very low stresses and the testing regime during production was not considered to be critical.

6) Particular problems encountered and overcome

Problems were initially encountered in welding the columns to the castings and a special jig had to be employed. Original designs included thirty potentially different casting patterns within the facade because of different corner conditions and tapering columns. However, by implementing a standardisation process, only nine different patterns were required.

7) Parties involved in the project

Client:	MEPC, IBM UK
Architect:	Michael Hopkins & Partners
Structural engineer:	Buro Happold
Steelwork contractor:	Booths Steelwork
Foundry:	William Cook Parkway

APPENDIX D Summary of recent projects using castings

Project	Architect	Structural engineer	Steelwork contractor	Foundry	Description of casting, unit weight and grade
Beckton Savacentre, London	Aukett Associates	WSP	J N Rowen	William Cook Parkway	Tube connectors, grade A4
Birmingham University College of Art	Associated Architects	Ove Arup & Partners	Kyle Stewart	William Cook Parkway	Floor support brackets, 29-92 kg, grade A4
Bridgewater Hall, Manchester	RHWL	Ove Arup & Partners	Fairport Construction	William Cook Parkway	Steel roof nodes, 160-300 kg, grade A4 modified
Bush Lane House	Arup Associates	Arup Associates	Boulton and Paul		Exposed stainless steel joints
Cambridge University, Department of Biochemistry	RHP	Whitby & Bird	Marriott Ltd	William Cook Parkway	Stainless steel roof supports, 1200 kg, grade 316
Charles de Gaulle Airport - railway station roof	Paul Andreu	RFR	Watson Steel	William Cook Parkway	Roof connectors, 10-70 kg, grade A4 modified
Clydebank Tourist Village	Ellis Williams Partnership	Doyle Partnership	George Depledge & Co Ltd	Thomas Clarke & Sons (Sheffield) Ltd	Steel fork-end connectors, grade A1
East Croydon Station	Alan Brookes Associates	Anthony Hunt Associates	Blight & White	John Smith	Stainless steel cladding support brackets
East Midlands Airport Terminal Building Redevelopment	Ove Arup	Ove Arup & Partners	Robinsons	Goodwin Steel Castings	Clevis end support strut, 50 kg, grade A4
Europier Heathrow Airport	Richard Rogers	Watermans	J N Rowen	William Cook Parkway	Roof tensioning forks, 4 kg, grade A4
Inland Revenue Building, Nottingham	Michael Hopkins & Partners	Ove Arup & Partners	Robinson Construction	William Cook Parkway	Roof tensioning forks, 4 kg each, grade A3
Inverness Aquatics Centre	Faulkner Browns	Cundall Johnson & Partners	Morrison Construction	William Cook Parkway	Roof support connectors, 13-50 kg, grade A4
Lee House	Terry Farrell	Ove Arup & Partners	Redpath	River Don	Steel nodes (2.2 x 1.4 m) in transfer structure, grade CSN3
Liverpool Street Station	British Rail Architectural Services Group	British Rail New Works Engineer (Anglia)	Watson Steel		Grey & SG iron filigrees for roof arches

Project	Architect	Structural engineer	Steelwork contractor	Foundry	Description of casting, unit weight and grade
London Underwriting Centre - hanging escalators	Anthony Hunt Associates	Anthony Hunt Associates	Westbury Tubular Structures	River Don	Steel hanger-tie rod connections
Ludvig Erhard Haus, Berlin, Germany	Nicholas Grimshaw	Whitby & Bird	Krup	Goodwin Steel Castings	Stainless steel foot and shoe, 1700 kg each, grade 316
Manchester Airport Terminal 2	Scott Brownrigg Turner, Manchester City Architect	Scott Wilson Kirkpatrick, Manchester City Engineers	Spacedecks Ltd	Stewart Baird	SG iron nodes for NODUS spaceframe canopy
Menil Gallery, Houston	Renzo Piano	Ove Arup & Partners			SG iron nodes in exposed roof trusses
Merchants Bridge, Castlefield, Manchester		Whitby & Bird	Watson Steel	Goodwin Steel Castings	Centre support strut, 400 kg, grade A3
National Exhibition Centre, Hall 10, Birmingham		Ove Arup & Partners	Tubeworkers		Steel fork-end connectors
New Free Bridge, Jackfield, Telford	Percy Thomas for Shropshire County Council	Gifford & Partners	Westbury Tubular Structures	Goodwin Steel Castings	Bearing base casting, 2500 kg, grade AL2
New Square, Bedford Lakes	Michael Hopkins & Partners	Buro Happold	Booths Steelwork	William Cook Parkway	Steel beam to column nodes, grade AL1
Park Lane Junior School	Tipton CC	Buro Happold	Tubeworkers	Goodwin Steel Castings	Beam to column nodes, 125 kg, grade A1
Pompidou Centre, Paris	Piano & Rogers	Ove Arup & Partners		Pohlig-Heckel-Bleichart	Large steel brackets (gerberettes), nodes in steel truss, bracing nodes, etc.
Ponds Forge International Sports Centre	Faulkner Browns	Ove Arup & Partners	Watson Steel	William Cook Hi-Tec	Steel roof truss nodes
Proctor & Gamble Headquarters	Aukett Associates	Portal UK	Glosford Fabrications	William Cook Parkway	Pin bases, 11 kg, grade A4 modified

Project	Architect	Structural engineer	Steelwork contractor	Foundry	Description of casting, unit weight and grade
Renault Centre, Swindon	Sir Norman Foster	Ove Arup & Partners	Tubeworkers	Exeter Castings	SG iron nodes in tension-stayed structure
Scottish Widows Building, Edinburgh		YRM	Tubeworkers	Goodwin Steel Castings	Main tube end connectors, 150 kg, grade A4
Stansted Airport	Sir Norman Foster	Ove Arup & Partners	Tubeworkers	William Cook Hi-Tec	Steel roof truss joints
Stratford Station, Jubilee Line Extension	Chris Wilkinson	Trafalgar House	Tubeworkers	Goodwin Steel Castings	Node and main strut castings, 250-3000 kg, grade A4
Sun Life Building, Bristol	GMW	Amec Design	Watson Steel	William Cook Parkway	Connectors, 40 kg, grade A4
Tees Barrage Bridge	The Napper Partnership	Ove Arup & Partners	Westbury Tubular Structures	William Cook Blackett Hutton	Steel circular infill members and bottom pivot plates, grade A4
Texaco petrol station canopy	Arup Associates	Ove Arup & Partners	Tubeworkers	Goodwin Steel Castings	Canopy support nodes, 250 kg, grade A4
Tsing Ma Bridge, Hong Kong		Mott MacDonald Hong Kong	Trafalgar House/ Cleveland/ Mitsui	Goodwin Steel Castings & William Cook Parkway	Cable clamp bands, 2000 kg, grade A4 Cable spinning pulleys strand clamps, grade AW2-3
Waterloo International Rail Terminal	Nicholas Grimshaw & Partners	Anthony Hunt Associates	Westbury Tubular Structures	Noel Village, Cronite & MBC Precision Castings	Steel nodes in roof truss, steel fork-ends (grade A4) and stainless steel glazing fixings (grade 316).
Water Sports Activity Centre, Liverpool	David Marks and Julia Barfield	Ove Arup & Partners	Tubeworkers	William Cook Parkway	Main branch support castings, 340 kg each, grade A3
Western Morning News HQ, Plymouth	Nicholas Grimshaw & Partners	Ove Arup & Partners	Blight & White	John Smith	SG iron glazing struts and arms. Stainless steel glazing fixings.

APPENDIX E Specifications and Standards relating to castings

BS 2789: 1985	Specification for spheroidal graphite or nodular graphite cast iron
BS 3100: 1991	Specification for steel castings for general engineering purposes
BS 3923	Methods for ultrasonic examination of welds Part 1: 1986 Methods for manual examination of fusion welds in ferritic steels
BS 4080	Specification for severity levels for discontinuities in steel castings Part 1: 1989 Surface discontinuities revealed by magnetic particle flaw detection Part 2: 1989 Surface discontinuities revealed by penetrant flaw detection
BS 4570: 1985	Specification for fusion welding of steel castings
BS 5135: 1984	Specification for arc welding of carbon and carbon manganese steels
BS 5289: 1976 (1983)	Code of practice. Visual inspection of fusion welded joints
BS 5950	Structural use of steelwork in building Part 1: 1990: Code of practice for design in simple and continuous construction: hot rolled sections
BS 6072: 1981 (1986)	Method for magnetic particle flaw detection
BS 6208: 1990	Method for ultrasonic testing of ferritic steel castings including quality levels
BS 6443: 1984	Method for penetrant flaw detection
BS 6615: 1996	Specification for dimensional tolerances for metal and metal alloy castings
BS EN 288	Specification and approval of welding procedures for metallic materials (various Parts)
BS EN 10213	Technical delivery conditions for steel castings for pressure purposes Parts 1 to 4: 1996

ASTM E94: 1992	Guide for radiographic testing
ASTM A802: 1989	Standard practice for steel castings, textures and discontinuities, surface acceptance standards, visual examination
ASTM E186: 1991	Reference radiographs for heavy walled (50 to 115 mm) steel castings
ASTM E280: 1991	Reference radiographs for heavy walled (115 to 300 mm) steel castings
ASTM E446: 1991	Reference radiographs for steel castings up to 50 mm in thickness
ANSI/AWS D11.2.89	Guide for welding iron castings
DIN 1690-2:1985	Technical delivery conditions for castings made from metallic materials. Steel castings; classification into severity levels on the basis of non-destructive testing
MSS-SP-55 1985 (R'90)	Quality standards for steel castings for valves, flanges and fittings and other piping components - visual methods (Produced by the Manufacturers' Standardisation Society of the valves and fittings industry.)

APPENDIX F Useful addresses

Avesta Sheffield Technical Advisory Centre
PO Box 161
Shepcote Lane
Sheffield S9 1TR
Tel: 0114 244 0060 Fax: 0114 242 0162

British Foundry Association (BFA)
Bridge House
Smallbrook Queensway
Birmingham
B5 4JP
Tel: 0121 643 3377 Fax: 0121 643 5064

British Steel Tubes & Pipes
PO Box 101
Weldon Road
Corby
Northants NN17 5UA
Tel: 01536 402121 Fax: 01536 404005

Cast Metals Development Ltd
Bordesley Hall
Alvechurch
Birmingham
B48 7QB
Tel: 01527 66414 Fax: 01527 585070

Castings Technology International (CTI)
7 East Bank Road
Sheffield
S2 3PT
Tel: 0114 272 8647 Fax: 0114 273 0852

Nickel Development Institute (NiDI)
42 Weymouth Street
London
W1N 3LQ
Tel: 0171 493 7999 Fax: 0171 493 1555

APPENDIX G Addresses of some UK foundries supplying structural castings to the construction industry

British Steel Engineering - Iron Foundries

Renishaw Foundry

Renishaw

Sheffield S31 9UY

Tel: 01246 432151

Fax: 01246 435092

Ability to produce a wide range of castings in haematite, spheroidal graphite, compacted graphite and low alloy irons with piece weights varying between 2 kg and 50 tonnes.

Cronite Precision Castings Ltd

Blacknell Lane

Crewkerne

Somerset

TA18 7HE

Tel: 01460 73394

Fax: 01460 72079

Roof rod supports, up to 2 kg in carbon steel and stainless steel. Manufactured by investment (lost wax) process.

Goodwin Steel Castings

Ivy House Road

Hanley

Stoke-on-Trent, ST1 3NR

Tel: 01782 208040

Fax: 01782 208060

Carbon, alloy and stainless steel structural and architectural castings. Weight range 50 kg to 7 tonnes. Computerised solidification simulation system to ISO 9001 accredited quality system. In house design and engineering facilities.

MBC Precision Castings Ltd

Shawbank Road

Lakeside

Redditch

Worcs B98 8YN

Tel: 01527 527501

Fax: 01527 502533

The major UK investment foundry manufacturing stainless steel spider castings for use with glass curtain walling.

Parkway Tubular Structures (William Cook Parkway)
(William Cook Blackett Hutton)
(William Cook Hi-Tec Integrity Castings)
(William Cook Holbrook Precision Castings)

Parkway Avenue
Sheffield, S9 4WA

Tel: 0114 273 0121

Fax: 0114 275 2508

All types of cast nodes/connectors for structural requirements are produced in weight ranges from under 1 kg to in excess of 20 tonnes. All British Standard BS 3100 materials are offered, together with non-standard analyses.

River Don Castings Ltd

PO Box 99

Brightside Lane

Sheffield S9 2RX

Tel: 0114 256 0008

Fax: 0114 243 4361

Design and supply of all types of structural steel castings, particularly offshore oil related, but also for bridges/buildings etc. Weight range is approx. 0.5 - 200 tonnes with sizes up to 13 m × 7.8 m × 4.7 m approximately.

Thomas Clarke (Bristol) Ltd

Meriton Street

Bristol BS2 0SZ

Tel: 0117 9779881

Fax: 0117 9724173

SG iron up to 0.5 tonne in weight, also bronze, brass, aluminium and BS 1452 cast iron.

Thomas Clarke & Sons (Sheffield) Limited

Bridge Foundry

401 Attercliffe Road

Sheffield S9 3QW

Tel: 0114 244 1142

Fax: 0114 243 1233

Steel hangers and connectors as used in the construction of the Clydebank Tourist Village. Iron and SG iron castings, ranging in weight from 1 kg to 3 tonnes.

Photographic credits

Figure reference	Figure title	Credit
Figure 2.2	Casting for Tees Barrage Bridge just after it was removed from the mould, with risers and feeder heads still attached	Westbury Tubular Structures plc
Figure 2.3	Predicted temperature distribution across a section of a steel node during solidification	William Cook Parkway
Figure 4.1	Cable band casting for the Tsing Ma Bridge undergoing a dimensional audit	Goodwin Steel Castings
Appendix C.1	Western Morning News Headquarters	Jo Reid and John Peck
Appendix C.1	SG iron glazing arms Stainless steel glazing boss	Ove Arup & Partners
Appendix C.2	Main truss pin cast connection and 'torpedo' shaped castings for internal truss tension nodes Stainless steel glazing connection	Anthony Hunt Associates
Appendix C.3	Tees Barrage Bridge Circular infill casting Base casting	Ove Arup & Partners
Appendix C.4	Beam to column cast connection	Martin Charles